



2021+ Ford F-150 (2.7L, 3.5L & 5.0L Engines)

Catback Exhaust Installation Instructions



**Thank you for your purchase, we appreciate your business.
If additional assistance is needed, please contact Kooks Headers and Exhaust
Toll free at 1-866-586-KOOK or contact your local dealer.**

- System Layout -

Components to ship with-

145.4" / 157.2" / 164.1" Wheelbase	
Rear exits	Side exits
(4) JI-TAS300 (8) JI-TAS250 (2) AB-FEH560	(4) JI-TAS300 (8) JI-TAS250 (2) AB-FEH560

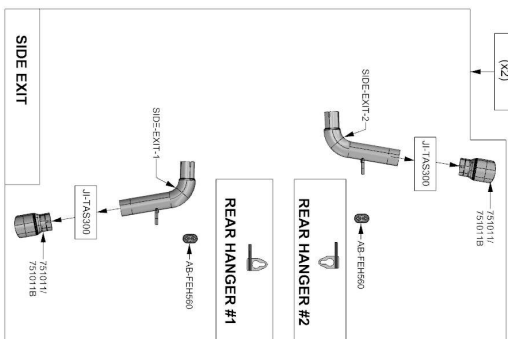
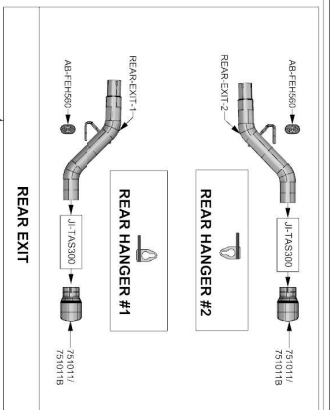
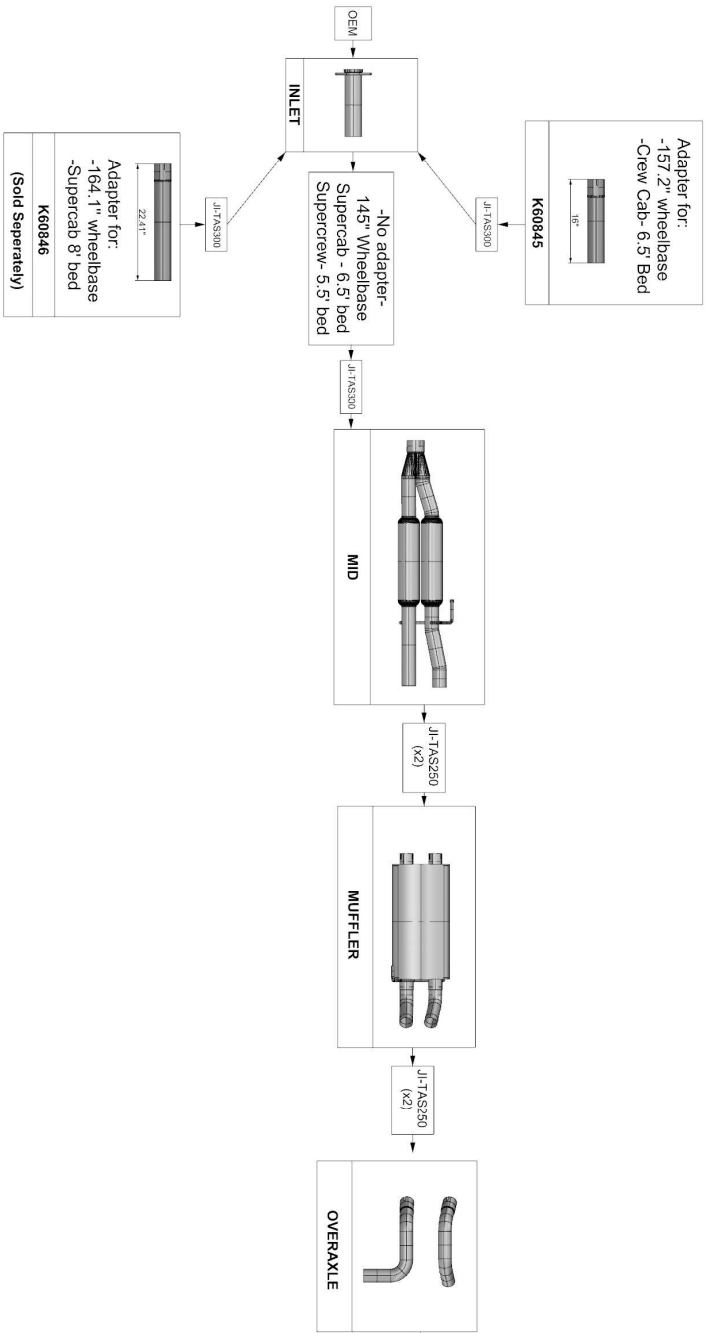

2021+ F-150 Catback

- 13704210 - Catback Rear Exit w/ Polished Tips
- 13704220 - Catback Rear Exit w/ Black Tips
- 13704230 - Catback Side Exit w/ Polished Tips
- 13704240 - Catback Side Exit w/ Black Tips



Do not attempt this installation if proper safety equipment is not available to you - seek the assistance of a professional installer

Read and understand all instructions before beginning

Vehicle Preparation

**Raise and Support Vehicle (Refer to Owner's Manual for specified jacking points) **

Always disconnect the battery before performing this type of work on any vehicle

2 Post Lift Recommended

KOOKS Catback Exhaust Installation

Part # Rear Exit - 13704210 (Polished Tips) / 13704220 (Black Tips)

Side Exit - 13704230 (Polished Tips) / 13704240 (Black Tips)

- OEM Exhaust system Removal -

- Step 1** - Use penetrating fluid on OEM rubber isolators holding up muffler.
- Step 2** - Remove spare tire from vehicle. (Unless you plan to cut the OEM system at overaxle pipes)
- Step 3** - Unbolt the clamp located in front of the muffler assembly and remove hangers from rubber isolators.
- Step 4** - Using a muffler stand or an additional person to support the exhaust system, loosen and Slide the clamp behind the OEM Muffler. Remove the hangers from the rubber isolators and remove the exhaust system from the vehicle.
- Step 5** - Remove the original isolator bracket from vehicle and transfer to your new Kooks system. See **Fig.1** for reference. If installing on trucks with 2.7L or 3.5L remove hanger noted in **Fig.1**
- Step 6** - If installing on 5.0L Truck, the muffler hanger needs to be moved forward on the frame rail using the OEM bolt holes in the frame approx. 3" forward. See **Fig.2**

**Thank you for your purchase, we appreciate your business.
If additional assistance is needed, please contact Kooks Headers and Exhaust
Toll free at 1-866-586-KOOK or contact your local dealer.**

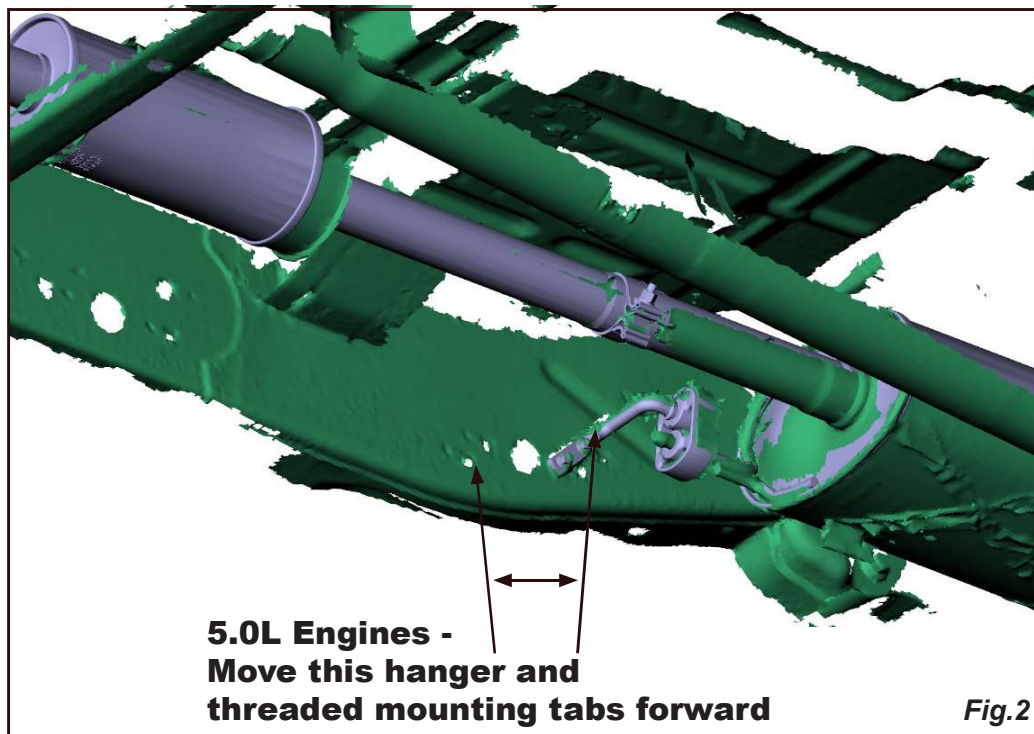
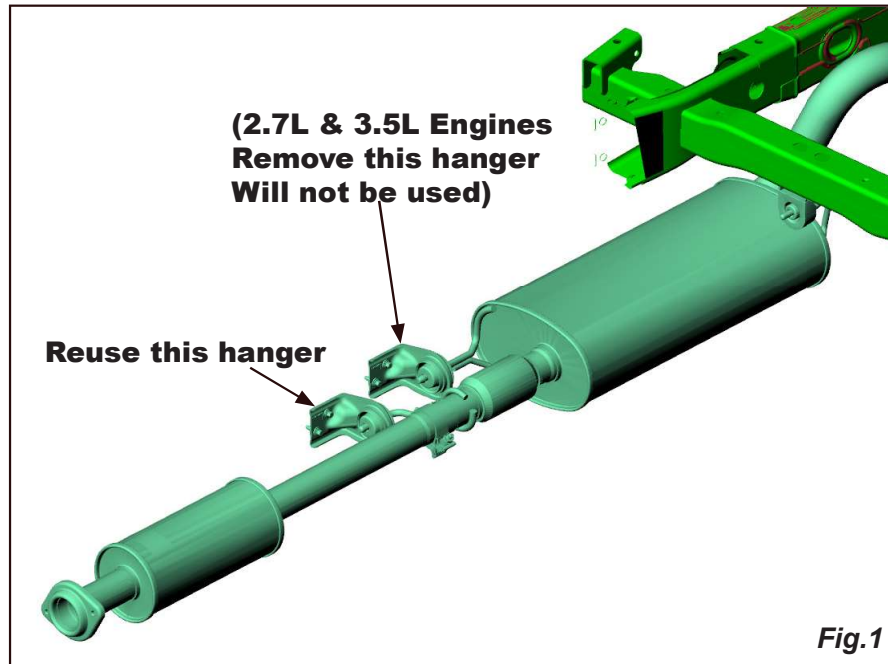



Do not attempt this installation if proper safety equipment is not available to you - seek the assistance of a professional installer

- KOOKS Catback Exhaust System Installation -

- Step 1** - Apply anti-seize lubricant liberally onto threads of all clamps.
- Step 2** - Place Inlet pipe onto OEM Front using the original hardware in place. Lightly tighten the bolts
- Step 3** - Determine if an extension tube is required for your model truck per the Layout on [page 2](#).
- Step 4** - Place a clamp over the expanded end of the Mid Pipe Assembly and insert the inlet into the Inlet pipe or Extension pipe if your model requires it. Insert the hanger into the rubber isolator. Do not tighten the clamp yet.
- Step 5** - Place clamps over the expanded ends of the Muffler Assembly and insert the inlets onto the Mid Pipe Assembly. Insert the hanger into the rubber isolator. Do not tighten the clamp yet.
- Step 6** - Place clamps over the Muff Out tubes on rear of Muffler. Then place Overaxle tubes onto their respective sides (#1 = Driver Side) (#2- Passenger Side) Align tubes for even fit and loosely tighten the clamps
- Step 7** - Install Hanger Bracket Assembly to left side and right rear leaf spring shackle bolts, see images for reference below. Do not fully remove bolts, only back out approx. 1/2".

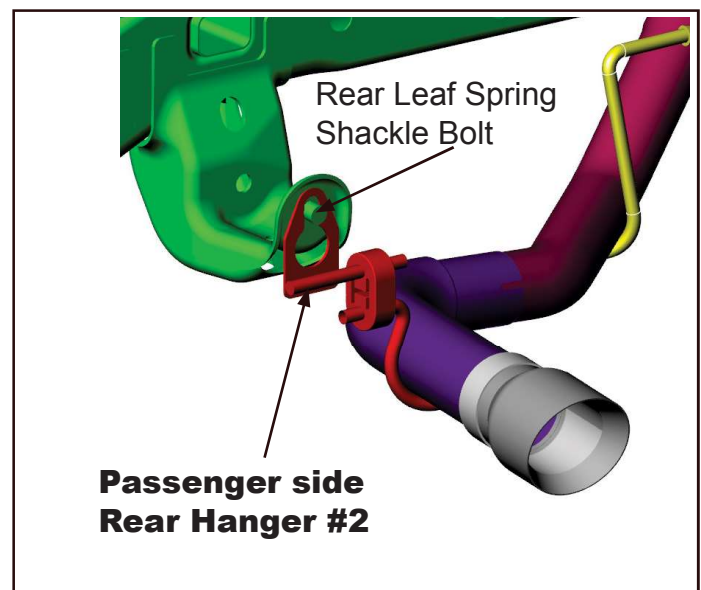
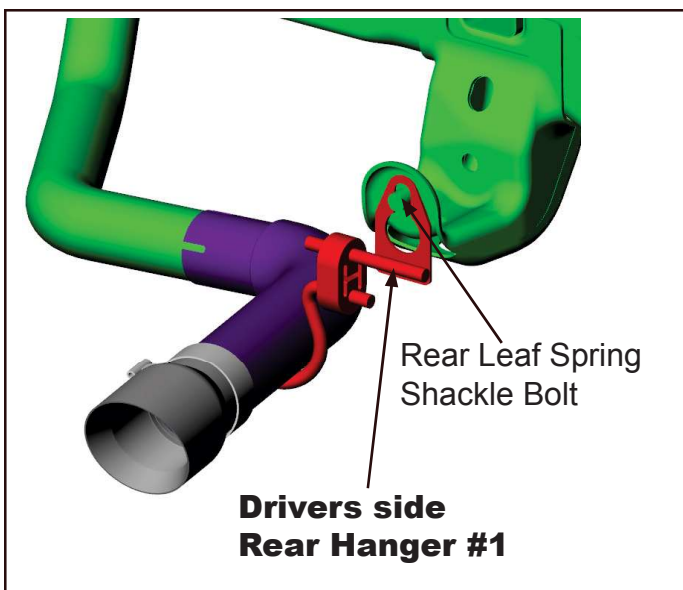



Do not attempt this installation if proper safety equipment is not available to you - seek the assistance of a professional installer

- Step 8** - Place a clamp over the expanded end of the R/H (#2) Tail Pipe Assembly and insert inlet to the right side outlet of the #2 Overaxle tube. Insert hanger into installed right side-side Hanger Bracket Assembly. Do not tighten the clamp yet.
- Step 9** - Place a clamp over the expanded end of the Cross Over Pipe Assembly and insert inlet to left side outlet of the Muffler Assembly. Place a clamp over the expanded end of the L/H (#1) Tail Pipe Assembly and insert inlet to the Cross Over Pipe Assembly. Do not tighten the clamps yet.
- Step 10** - Place clamps onto reduced and notched end of Exit tubes and slide onto rear connection pipe outlets while placing hanger into rubber isolator connecting to recently installed hangers on rear shackle bolts. Do not tighten clamps yet.
- Step 11** - Place 3" clamps onto rear exit pipes while placing Tips onto exit of tubes. Lightly tighten and align tips to have KOOKS logo facing up.
- Step 12** - Reinstall spare tire to vehicle.
- Step 13** - Tighten clamps starting at front of system to 32-35 ft.lbs
- Step 14** - Before starting your vehicle, make sure to check all wires, hoses, brake lines, body parts and tires for safe clearance from the exhaust system.
- Step 15** - Start vehicle and test system for leaks. Allow vehicle to complete one heat cycle (heat to operating temperatures and allow for cooling). Re-torque clamps.

**Thank you for your purchase, we appreciate your business.
If additional assistance is needed, please contact Kooks Headers and Exhaust
Toll free at 1-866-586-KOOK or contact your local dealer.**