



INTAKE SYSTEMS FOR VEHICLES LISTED ARE 50 STATE LEGAL. SEE KNFILTERS.COM FOR CARB STATUS ON EACH PART FOR A SPECIFIC VEHICLE.

# INSTALLATION INSTRUCTIONS

**57-3055**  
**CHEVROLET**  
**2005-06 SSR**  
**V8 6.0L**

NOTE: This kit was not designed to fit vehicles with a body lift.

**TOOLS NEEDED:**

Flat Blade Screw

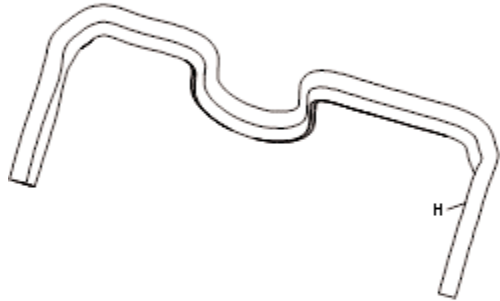

NOTE: FAILURE TO FOLLOW INSTALLATION INSTRUCTIONS AND NOT USING THE PROVIDED HARDWARE MAY DAMAGE THE INTAKE TUBE, THROTTLE BODY AND ENGINE.

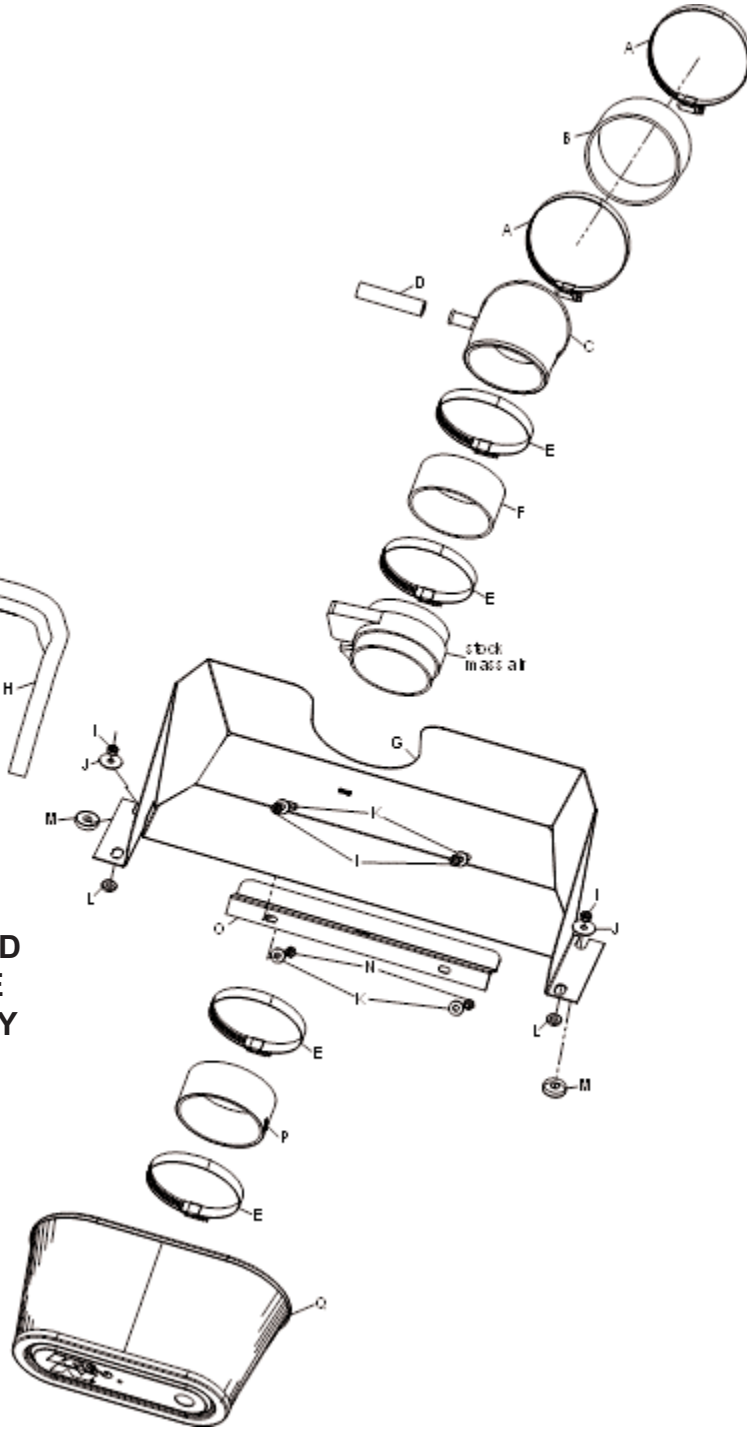

**PARTS LIST:**

Desc.	Qty.	Part #
A hose clamp #64	2	08645
B hose; 4.0" id x 2' l silicone	1	08625
C intake tube (XX)	1	087180
D hose; 3/8" id x 3' l silicone	1	08462
E hose clamp #60	4	08628
F hose; 3.63" id x 1.75" silicone	1	08615
G heat shield	1	07665
H edge trim 42"	1	102499
I nut, 6mm nylock	4	07553
J washer; 1/4" id x 1.0" od	2	08160
K washer; 1/4" id x 5/8" od flat	4	08275
L washer; 5/16" id x 5/8" od flat	2	08276
M spacer; 1.0" od x .37" id x .23" thk, nylon	2	08281
N bolt; 6mm-1.00 x 16mm hex	2	07703
O bracket; heat shield	1	010065
P hose; 3.75" id x 1.75" silicone	1	08621
Q air filter	1	RP-5115



8. Loosen the hose clamp that secures the stock intake tube to the throttle body, and then remove the complete intake assembly from the vehicle.

NOTE: K&N recommends that you do not discard your factory air intake.

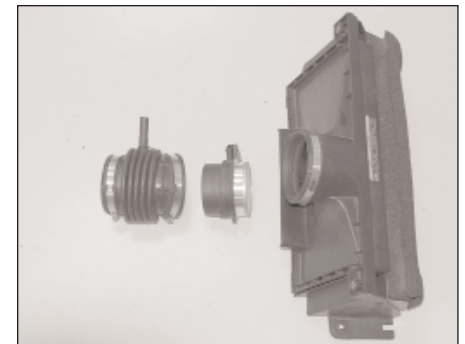

9. Loosen the two hose clamps securing the mass air sensor to the stock air box and intake tube, and then remove the mass air sensor.



10. Install the supplied upper radiator hose support (010065) with the provided hardware onto the heat shield as shown.

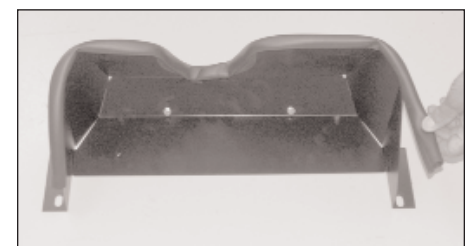

11. Install the provided edge trim onto the heat shield as shown.



12. Install the two 5/16" id washers onto the front airbox mounting points as shown.

**TO START:**

1. Turn the ignition OFF and disconnect the vehicle's negative battery cable.



2. Disconnect the mass air sensor electrical connection.

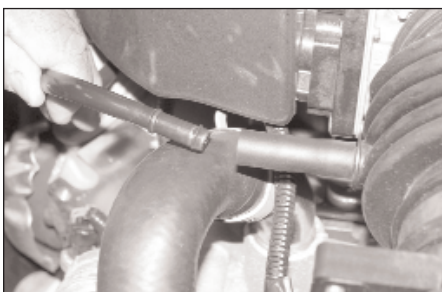

3. Disconnect the crank case vent hose from the stock intake tube as shown.



4. Release the center locking pins in the two-core support cover holding clips, and then pull the holding clips out.



5. Remove the two 10mm nuts, which hold the core support cover onto the air box.



6. Lift the core support cover up and remove it from the vehicle.



7. Remove the two bolts, which secure the air box to the core support.

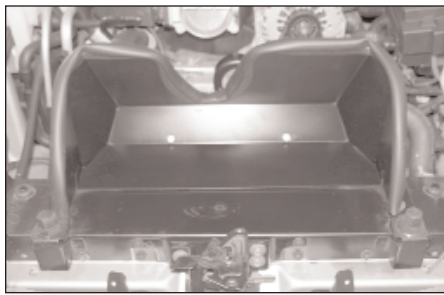

13. Install the heat shield assembly onto the air box mounting points and secure with the factory air box mounting bolts.

**NOTE: Make sure the upper radiator hose is resting on the K&N support bracket installed in step #10.**



14. Install the provided silicone hose (08625) onto the throttle body and secure with the provided hose clamp as shown.



15. Install the K&N intake tube into the silicone hose at the throttle body and secure with the provided hose clamp.

**NOTE: Do not completely tighten at this time.**



16. Install the provided silicone hose (08615) onto the engine side of the mass air sensor and secure with the provided hose clamp.

**NOTE: The arrow on the side of the mass air sensor indicates the directions of air flow.**

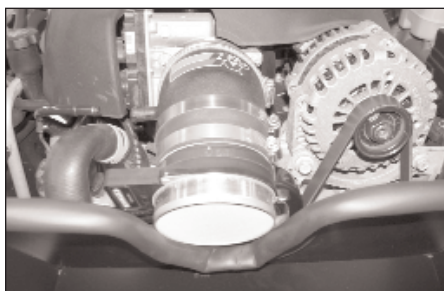

17. Install the mass air sensor assembly onto the K&N intake tube and secure with the provided hose clamp.

**NOTE: Do not tighten completely at this time.**

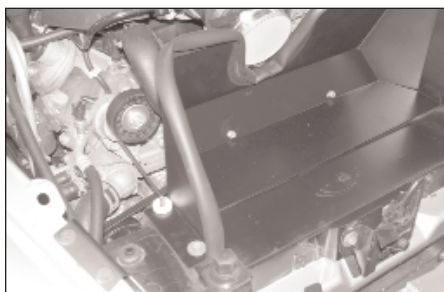

18. Install the two provided nylon spacers onto each side of the air box mounting studs as shown.

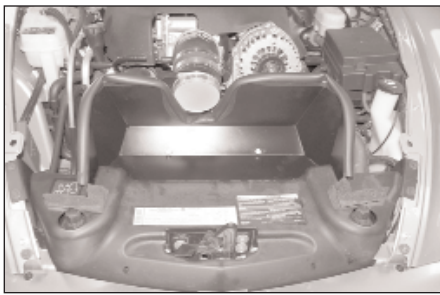

19. Reinstall the core support cover removed in step #4 and secure with the factory retaining clips and provided hardware.

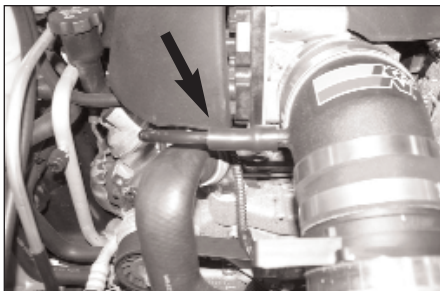

20. Install the provided crank case vent hose onto the K&N intake tube and then connect the factory vent tube into the K&N vent hose as shown.



21. Install the provided silicone hose (08621) onto the air filter and secure with the provided hose clamps as shown.



22. Note the flange of the air filter is offset. The offset is to the top of the filter.



23. Install the air filter onto the mass air sensor and secure with the provided hose clamp.

**NOTE: The offset of the air filter flange should be to the top when the filter is installed.**



24. Reconnect the mass air sensor electrical connection.

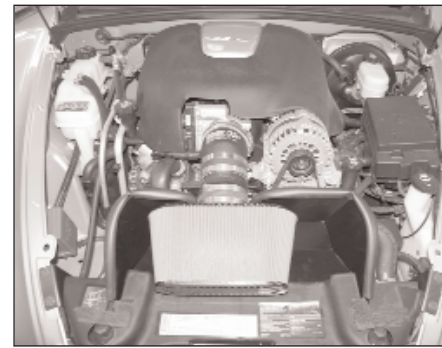

25. Reconnect the vehicle's negative battery cable. Double check to make sure everything is tight and properly positioned before starting the vehicle.

26. The C.A.R.B. exemption sticker, (attached), must be visible under the hood so that an emissions inspector can see it when the vehicle is required to be tested for emissions. California requires testing every two years, other states may vary.

27. It will be necessary for all FIPK's to be checked periodically for realignment, clearance and tightening of all connections. Failure to follow the above instructions or proper maintenance may void warranty.

#### ROAD TESTING:

1. Start the engine with the transmission in neutral or park, and the parking brake engaged. Listen for air leaks or odd noises. For air leaks secure hoses and connections. For odd noises, find cause and repair before proceeding. This kit will function identically to the factory system except for being louder and much more responsive.

2. Test drive the vehicle. Listen for odd noises or rattles and fix as necessary.

3. If road test is fine, you can now enjoy the added power and performance from your kit.

4. K&N suggests checking the air filter element periodically for excessive dirt build-up. When the element becomes covered in dirt (or once a year), service it according to the instructions on the Recharger service kit, part number 99-5050 or 99-5000.

**INTAKE SYSTEMS FOR VEHICLES LISTED ARE 50 STATE LEGAL. SEE KNFILTERS.COM FOR CARB STATUS ON EACH PART FOR A SPECIFIC VEHICLE.**