



INTAKE SYSTEMS FOR VEHICLES LISTED ARE 50 STATE LEGAL. SEE KNFILTERS.COM FOR CARB STATUS ON EACH PART FOR A SPECIFIC VEHICLE.

INSTALLATION INSTRUCTIONS

57-9038
LEXUS
2015-17 RC-F
V8-5.0L

TOOLS NEEDED:
 Flat Blade Screw Driver
 Phillips Screw driver
 3/4" wrench

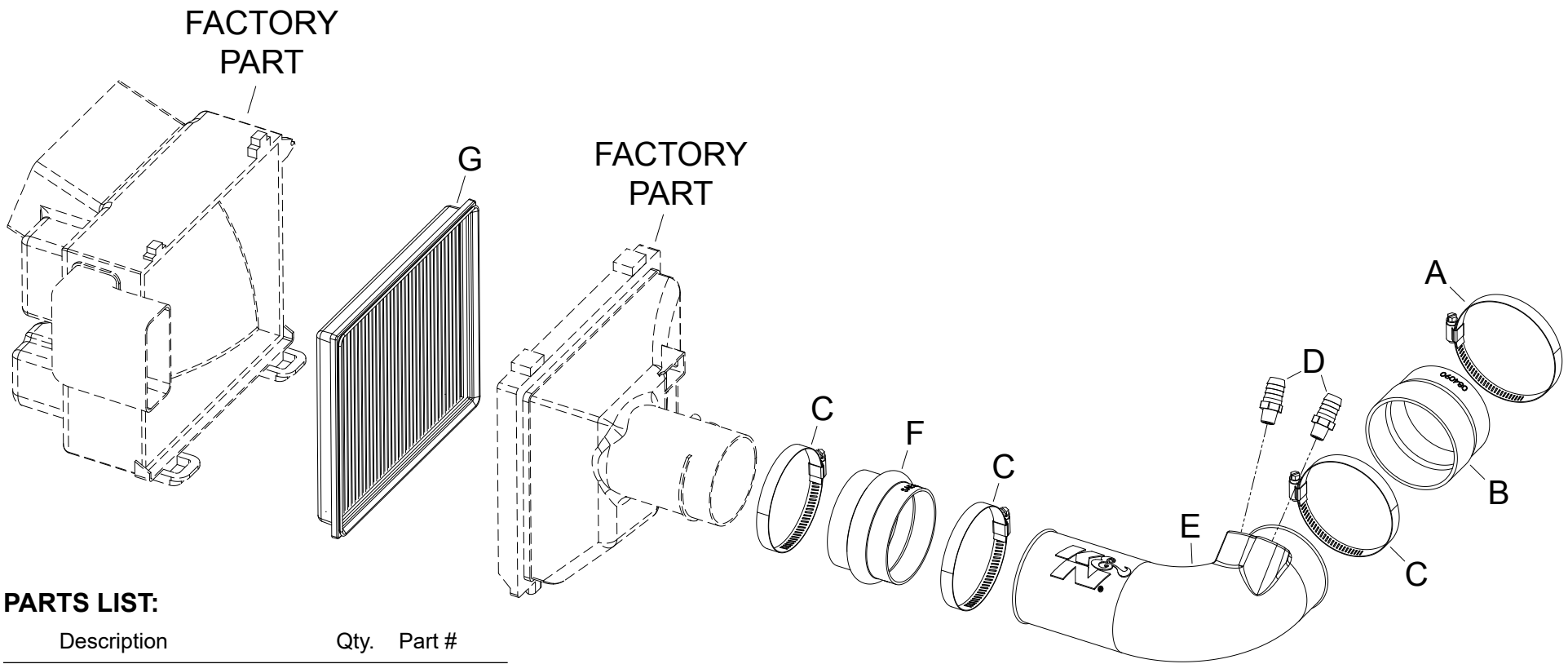

PARTS LIST:

Description	Qty.	Part #
A HOSE CLAMP #60 STAINLESS	1	08628
B HOSE; 3-5/8" TO 3.5"ID X 2.5"L	1	084090
C HOSE CLAMP #56	3	08620
D VENT; STRT, 5/8 BARBED 1/4	2	82638
E INTAKE TUBE; (KK)	1	087307A
F HOSE; HUMP 3.5"ID X 2.5"L	1	08699
G FILTER	1	33-2453

If you need any assistance please call 1-800-858-3333 to speak with a representative in our Customer Service Center before returning the product.

NOTE: FAILURE TO FOLLOW INSTALLATION INSTRUCTIONS AND NOT USING THE PROVIDED HARDWARE MAY DAMAGE THE INTAKE TUBE, THROTTLE BODY AND ENGINE.

TO START:

1. Turn off the ignition and disconnect the negative battery cable.
NOTE: Disconnecting the negative battery cable erases pre-programmed electronic memories. Write down all memory settings before disconnecting the negative battery cable. Some radios will require an anti-theft code to be entered after the battery is reconnected. The anti-theft code is typically supplied with your owner's manual. In the event your vehicles anti-theft code cannot be recovered, contact an authorized dealership to obtain your vehicles anti-theft code.



2. Release the spring clamps securing the crank case breather hoses and then disconnect the hoses from the intake tube.

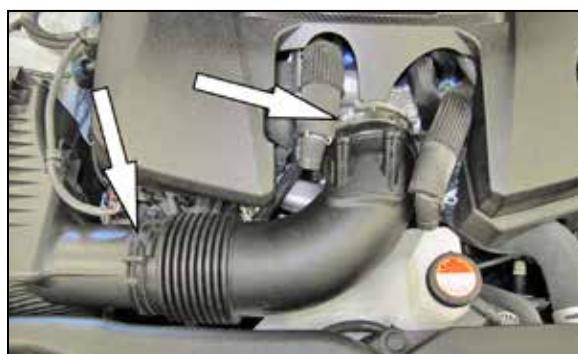

3. Loosen the hose clamps that secure the intake tube to the throttle body and air filter housing and then remove the intake tube from the vehicle.
NOTE: K&N Engineering, Inc., recommends that customers do not discard factory air intake.

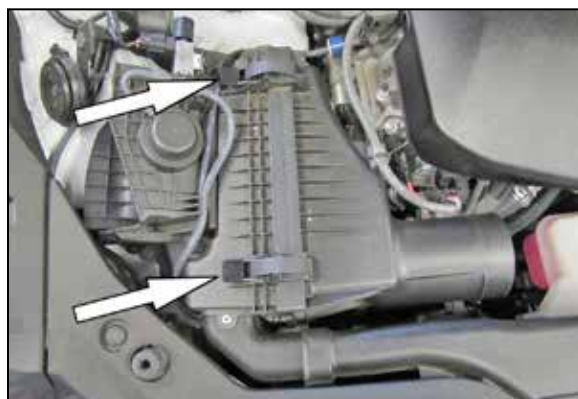

4. Release the two clips retaining the clean side of the filter housing.



5. Place the housing up out of the way and remove the stock air filter from the lower housing.



6. Install the K&N® air filter and then resecure the clean side housing.

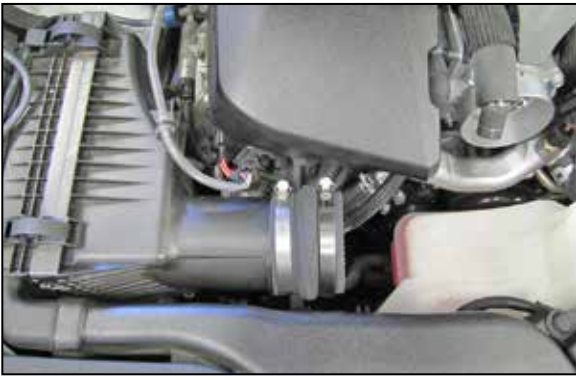

7. Install the coupling hose (08699) onto the air filter housing and secure with the provided hose clamp.



8. Install the coupling hose (084090) onto the throttle body and secure with the provided hose clamp.



9. Install the provided vent fittings into the K&N® intake tube as shown.

NOTE: NPT fitting has tapered threads and only designed to be installed until hand tight, then tighten one rotation or when the fitting becomes difficult to return.



10. Install the K&N® intake tube assembly into the coupler at the air filter housing and then into the coupler at the throttle body. Adjust the tube for best fit and then secure with the provided hose clamps.



11. Install the crank case breather hoses and then secure with the factory spring clamps.



12. Reconnect the vehicle's negative battery cable. Double check to make sure everything is tight and properly positioned before starting the vehicle.

13. The C.A.R.B. exemption sticker, (attached), must be visible under the hood so that an emissions inspector can see it when the vehicle is required to be tested for emissions. California requires testing every two years, other states may vary.

14. It will be necessary for all K&N® high flow intake systems to be checked periodically for realignment, clearance and tightening of all connections. Failure to follow the above instructions or proper maintenance may void warranty.

ROAD TESTING:

1. Start the engine with the transmission in neutral or park, and the parking brake engaged. Listen for air leaks or odd noises. For air leaks secure hoses and connections. For odd noises, find cause and repair before proceeding. This kit will function identically to the factory system except for being louder and much more responsive.

2. Test drive the vehicle. Listen for odd noises or rattles and fix as necessary.

3. If road test is fine, you can now enjoy the added power and performance from your kit.

4. K&N Engineering, Inc., requires cleaning the intake system's air filter element every 100,000 miles. When used in dusty or off-road environments, our filters will require cleaning more often. We recommend that you visually inspect your filter once every 25,000 miles to determine if the screen is still visible. When the screen is no longer visible some place on the filter element, it is time to clean it. To clean and re-oil, purchase our filter Recharger® service kit, part number 99-5050 or 99-5000 and follow the easy instructions.

INTAKE SYSTEMS FOR VEHICLES LISTED ARE 50 STATE LEGAL. SEE KNFILTERS.COM FOR CARB STATUS ON EACH PART FOR A SPECIFIC VEHICLE.