



AIRCHARGER®

HIGH-FLOW INTAKE KITS

NOT LEGAL FOR SALE OR USE ON ANY POLLUTION CONTROLLED MOTOR VEHICLE IN CALIFORNIA OR STATES ADOPTING CALIFORNIA EMISSION PROCEDURES.
See knfilters.com for CARB status on each part for a specific vehicle

INSTALLATION INSTRUCTIONS

63-1581
JEEP
2012-18 Wrangler JK
V6-3.6L

NOTE: This kit was not designed to fit vehicles with a body lift.

TOOLS NEEDED:

- Ratchet
- Extension
- 10mm socket
- 7mm socket
- 4mm allen key
- 2.5mm allen key
- 10mm wrench
- flat blade screw driver
- side cutters

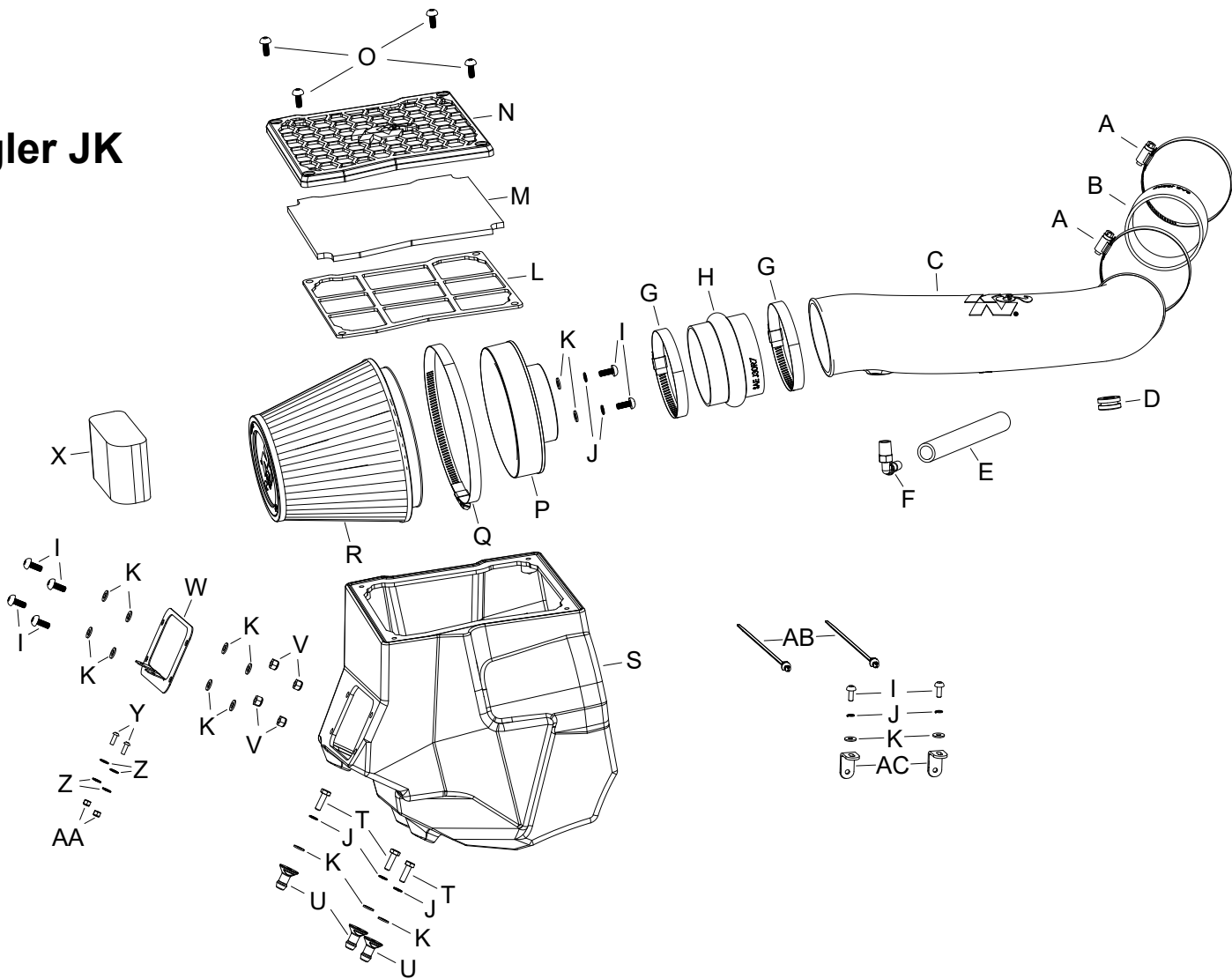

PARTS LIST:

Description	Qty.	Part #	Description	Qty.	Part #	Description	Qty.	Part #
A HOSE CLAMP; #52	2	08610	K WASHER; 6MM FLAT, SS	15	08269	U MOUNT, PLASTIC AIRBOX	3	8-186-1
B HOSE; 3.25"ID X 2"L	1	08690	L FRAME; PRECLEANER	1	088071	V NUT; 6MM NYLOCK, HEXHEAD	4	07512
C TUBE; AIRCHARGER, XLHDPE	1	087312A	M FOAM INSERT	1	971968	W BRACKET; 31%-132, TB/PC	1	KIT132BC
D GROMMET; 1"OD, 1/2"ID, 1/2"	1	08064	N FRAME; PRECLEANER TOP	1	088070	X PLUG; FOAM INSERT, 63-1573	1	971967
E HOSE; 5/8"ID X 14"L	1	084083	O BOLT; 1/4-20 X 1/2" BUTTON	4	07706	Y SCREW; M4-.7 X 12, BUTTON	2	07726
F FITTING; VENT 1/4NPT, 90DEG	1	08525	P ADAPTER; UNIVERSAL, 6"	1	21512-1	Z WASHER; 4MM FLAT	4	08278
G HOSE CLAMP; #56	2	08620	Q HOSE CLAMP; #104	1	08697	AA NUT; 4MM NYLOCK	2	07501
H HOSE; HUMP 3.5"ID X 2.5"L	1	08699	R 6"FLG, 7-1/2"B, 4-1/2"T, 6"H	1	RF-10480	AB ZIP TIE; 8" TREE PUSH-MNT	2	1-127
I BOLT; M6 X 1.00 X 16MM, SS	8	07730	S AIR BOX; AIRCHARGER, MZ	1	087442	AC BRACKET; "L", 69-2521, SML	2	070066A
J WASHER; M6 SPLIT LOCK ZINC	7	1-3025	T BOLT; M6-1.00 X 16MM, SS	3	07812			

If you need any assistance please call 1-800-858-3333 to speak with a representative in our Customer Service Center before returning the product.

NOTE: FAILURE TO FOLLOW INSTALLATION INSTRUCTIONS AND NOT USING THE PROVIDED HARDWARE MAY DAMAGE THE INTAKE TUBE, THROTTLE BODY AND ENGINE.

TO START:

1. Turn off the ignition and disconnect the negative battery cable.
NOTE: Disconnecting the negative battery cable erases pre-programmed electronic memories. Write down all memory settings before disconnecting the negative battery cable. Some radios will require an anti-theft code to be entered after the battery is reconnected. The anti-theft code is typically supplied with your owner's manual. In the event your vehicles anti-theft code cannot be recovered, contact an authorized dealership to obtain your vehicles anti-theft code.



2. Lift up the engine cover to dislodge it from the mounting studs and then remove the cover from the engine.



3. Remove the two bolts that secure the factory intake tube to the fan shroud.



4. Loosen the two hose clamps that secure the intake tube and disconnect the inlet air temperature sensor electrical connection. Remove the factory intake tube from the vehicle.



5. Disconnect the crank case vent flex line from the hardline at the connection shown.



6. Remove the factory air filter housing from the vehicle.
NOTE: K&N Engineering, Inc., recommends that customers do not discard factory air intake.

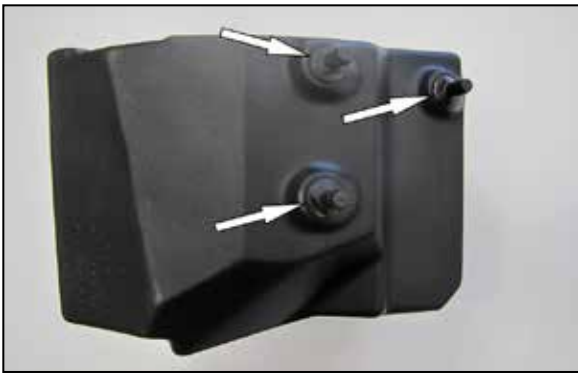

7. Install the three mounting studs provided onto the K&N® air filter housing using the provided hardware.



8. Install the provided filter adapter into the housing and secure with the provided hardware.



9. Using a 1/8" drill, drill out the two rivets that secure the factory fresh air duct to the factory air filter housing and then remove the duct from the housing as shown.



10. Install the provided fresh air scoop mounting bracket onto the fresh air scoop and secure with the provided hardware.



11. Install the fresh air intake assembly into the K&N® air filter housing and secure with the provided hardware.



12. Install the K&N® air filter housing into the vehicle so the mounting studs insert into the factory mounting brackets.

NOTE: During extreme conditions a foam plug has been provided to install into the fresh air intake duct to reduce the debris that enters into the air box.



13. Install the provided coupler (08690) onto the throttle body and secure with the provided hose clamp.



14. Remove the inlet air temperature sensor from the factory intake tube. Using the provided grommet install the inlet air temperature sensor into the K&N® intake tube.

NOTE: The inlet air temperature sensor is very fragile, use caution while handling the sensor.



15. Install the provided 90° fitting into the K&N® intake tube as shown.

NOTE: Plastic NPT fittings are easy to cross thread. Install the vent fitting "hand" tight, then turn it two complete turns with a wrench.



16. Install the provided hump coupler (08699) onto the K&N® intake tube and then install the assembly into the vehicle. Adjust the tube for best fit and then secure with the provided hose clamps. Reconnect the inlet air temperature sensor electrical connection.



17. Install the provided crank case vent line onto the fitting installed into the intake tube and onto the factory hardline.



18. Install the provided tie wraps onto the two "L" brackets as shown.



19. Install the "L" brackets onto the fan shroud using the provided hardware and then secure the coolant hose with the tie wraps.



20. Install the K&N® air filter onto the adapter and secure with the provided hose clamp.



21. Assemble the three parts of the filter lid.



22. Install the filter lid onto the air filter housing and secure with the provided hardware.

NOTE: A foam insert has been provided to use in the fresh air intake duct during extreme conditions.



23. Reinstall the engine cover.



24. Reconnect the vehicle's negative battery cable. Double check to make sure everything is tight and properly positioned before starting the vehicle.

25. It will be necessary for all K&N® high flow intake systems to be checked periodically for realignment, clearance and tightening of all connections. Failure to follow the above instructions or proper maintenance may void warranty.

ROAD TESTING:

1. Start the engine with the transmission in neutral or park, and the parking brake engaged. Listen for air leaks or odd noises. For air leaks secure hoses and connections. For odd noises, find cause and repair before proceeding. This kit will function identically to the factory system except for being louder and much more responsive.

2. Test drive the vehicle. Listen for odd noises or rattles and fix as necessary.

3. If road test is fine, you can now enjoy the added power and performance from your kit.

4. K&N Engineering, Inc., requires cleaning the intake system's air filter element every 100,000 miles. When used in dusty or off-road environments, our filters will require cleaning more often. We recommend that you visually inspect your filter once every 25,000 miles to determine if the screen is still visible. When the screen is no longer visible some place on the filter element, it is time to clean it. To clean and re-oil, purchase our filter Recharger® service kit, part number 99-5050 or 99-5000 and follow the easy instructions.

NOT LEGAL FOR SALE OR USE ON ANY POLLUTION CONTROLLED MOTOR VEHICLE IN CALIFORNIA OR STATES ADOPTING CALIFORNIA EMISSION PROCEDURES.

See knfilters.com for CARB status on each part for a specific vehicle