



AIRCHARGER®

HIGH-FLOW INTAKE KITS

NOT LEGAL FOR SALE OR USE ON ANY POLLUTION CONTROLLED MOTOR VEHICLE IN CALIFORNIA OR STATES ADOPTING CALIFORNIA EMISSION PROCEDURES.
See knfilters.com for CARB status on each part for a specific vehicle

INSTALLATION INSTRUCTIONS

63-3110

CHEVROLET / GMC / CADILLAC

2019-24 Silverado / Sierra

2021-24 Tahoe / Yukon

2021-24 Suburban / Escalade

V8-5.3L / 6.2L

TOOLS NEEDED:

- phillips screw driver
- flat blade screw driver
- ratchet
- extension
- 10mm deep socket
- 3mm allen key
- 4mm allen key
- t10 torx
- t20 torx
- pick

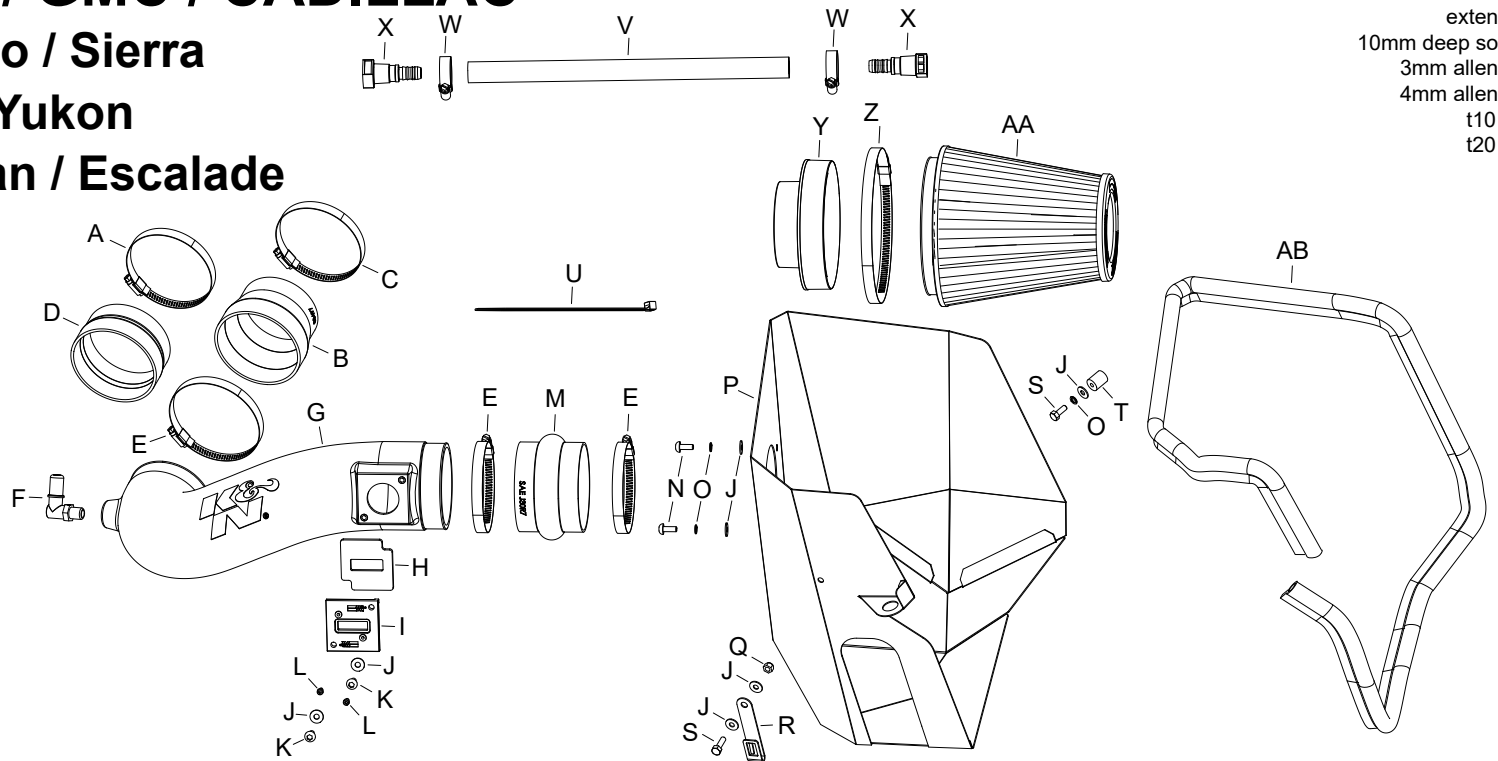

PARTS LIST:

Description	Qty.	Part #	Description	Qty.	Part #	Description	Qty.	Part #
A HOSE CLAMP; #60	1	08624	K BOLT; M6-1 X 12MM BTNHD	2	07794	U CABLE TIE; 11" BLACK	1	21590
B HOSE; 4"ID TO 3.5"ID X 3"L	1	08497	L BOLT; M4-.7 X 8MM; ALNHD	2	07733	V HOSE; 5/8"ID X 15"L	1	5-7015
C HOSE CLAMP; #56	1	08620	M HOSE; HUMP 4"ID X 3"L	1	08418	W HOSE CLAMP; #10 MINI	2	08411
D HOSE; 4"ID TO 3-13/16"ID X 3"L	1	084107	N BOLT; M6 X 1 X 16MM BTNHD	2	07730	X FITTING; 16-14MM PCV	2	08526
E HOSE CLAMP; #64, STAINLESS	3	08645	O WASHER; M6 SPLIT LOCK ZINC	3	1-3025	Y ADAPTOR; #454	1	27300
F VENT; 90"D, 1/4"NPT, TO .600"	1	82633	P HEAT SHIELD	1	073283	Z HOSE CLAMP; #104	1	08697
G INTAKE TUBE; (MC)	1	087418A	Q NUT; 6MM NYLOCK HEXHD	1	07512	AA AIR FILTER	1	RU-1041
H GASKET; 3/16" PORON	1	09069	R BRACKET	1	064358A	AB EDGE TRIM; (61"L)	1	102492
I ADAPTOR; MAF SENSOR	1	21515-1	S BOLT; M6 X 1 X 12MM HEXHD	2	07727			
J WASHER; 6MM FLAT	7	08269	T THREADED BOSS; 5/8"OD	1	081004			

If you need any assistance please call 1-800-858-3333 to speak with a representative in our Customer Service Center before returning the product.

NOTE: FAILURE TO FOLLOW INSTALLATION INSTRUCTIONS AND NOT USING THE PROVIDED HARDWARE MAY DAMAGE THE INTAKE TUBE, THROTTLE BODY AND ENGINE.

TO START:

1. Turn off the ignition and disconnect the negative battery cable.
NOTE: Disconnecting the negative battery cable erases pre-programmed electronic memories. Write down all memory settings before disconnecting the negative battery cable. Some radios will require an anti-theft code to be entered after the battery is reconnected. The anti-theft code is typically supplied with your owner's manual. In the event your vehicles anti-theft code cannot be recovered, contact an authorized dealership to obtain your vehicles anti-theft code.



2. Disconnect the mass air sensor electrical connection.



3. Depress the locking tabs and then disconnect the crank case vent line from the intake plenum and valve cover vent port.



4. Loosen the hose clamps that secures the intake plenum to the air filter housing and to the throttle body. Disconnect the plenum connections at the air filter housing and then rotate the plenum counter clockwise to disengage the keyed mount and separate it from the throttle body.
NOTE: The wiring harness anchored to the intake plenum will need to be detached before removing the plenum from the vehicle.



5. Remove the two bolts that secure the hood release arm to the hood latch and then remove the arm.



6. Release the ten retaining clips that secure the upper radiator valence and then remove the valence from the vehicle.



7. Remove the plastic retaining clip that secures the fresh air intake duct to the core support, then pull the duct forward to disengage it from the factory air filter housing.



8. Using a small 90° pick or similar tool, release the locking tab that secures the wiring harness bulk connector to the air filter housing and then unhook the connector from the housing.



9. Remove the nut that secures the air filter housing. Unhook the wiring harness from the filter housing and then remove the air filter housing from the vehicle.

NOTE: Go slow and use caution to remove the housing. It is indexed into two holes in the rear with rubber grommets that can fall off easily and be lost. It is a tight fit but will come out without being forced. These grommets and nut will be reused in later steps.

NOTE: K&N Engineering, Inc., recommends that customers do not discard factory air intake.



10. Install the provided edge trim onto the heat shield as shown.

NOTE: Some trimming of the edge trim will be necessary.

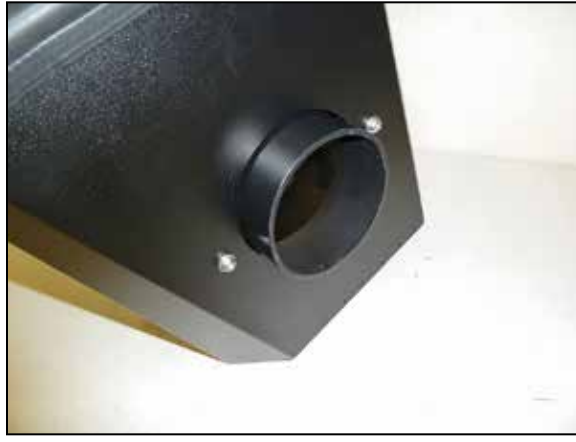

11. Install the provided filter adapter into the heat shield and secure with the provided hardware.



12. Install the provided wiring connector mounting bracket onto the heat shield using the provided hardware. Install the factory mounting grommet into the heat shield as shown.



13. Install the provided grommet mount onto the heat shield using the provided hardware and then install the factory mounting grommet onto the mount as shown.



14. Install the heat shield assembly into the vehicle so the mounting grommet slides into the factory mounting hole. Slide the fresh air intake scoop into the opening in the heat shield and resecure to the core support with the factory clip. Secure the heat shield with the factory nut removed in step #9.



15. Connect the wiring bulk connector onto the bracket installed onto the heat shield.



16. Reinstall the radiator valence and secure with the ten factory clips.



17. Reinstall the hood release arm and secure with the factory hardware.



18. Install the provided hump coupler onto the filter adapter and secure with the provided hose clamp.



19. Install the provided reducer coupler onto the throttle body and secure with the provided hose clamp.

NOTE: On 5.3L equipped vehicles use coupler #08497, on 6.2L vehicles use coupler #084107.



20. Install the provided 90° quick connect fitting into the K&N® intake tube as shown.

NOTE: Plastic NPT fittings are easy to cross thread. Install the vent fitting "hand" tight, then turn it two complete turns with a wrench.

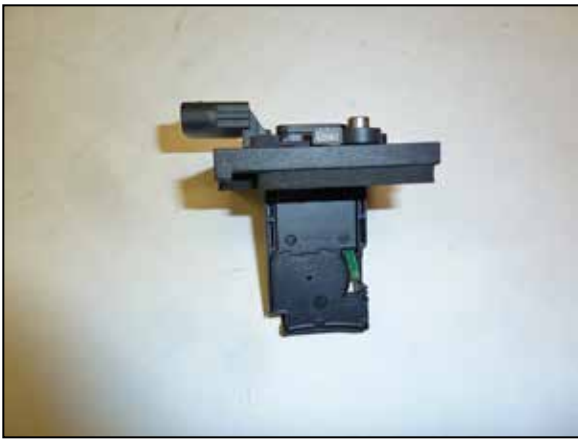

21. Install the provided gasket onto the K&N® mass air adapter. Remove the mass air sensor from the factory housing and install it into the mass air adapter and secure with the provided hardware.



22. Install the mass air sensor into the K&N® intake tube and secure with the provided hardware.



23. Install the intake tube into the coupler at the filter adapter and then into the coupler at the throttle body, adjust the tube for best fit and then secure with the provided hose clamps.



24. Install the provided quick connect fittings into the provided crank case vent hose and secure with the provided hose clamps.



25. Connect the crank case vent hose assembly to the valve cover port and then to the fitting installed into the intake tube.



26. Connect the mass air sensor electrical connection.



27. Install the K&N® air filter onto the adapter and secure with the provided hose clamp.



28. Reconnect the vehicle's negative battery cable. Double check to make sure everything is tight and properly positioned before starting the vehicle.

29. **K&N AIR FILTER MONITOR LIGHT:** Some vehicles are equipped with a "Air Filter Monitor" system that will send a message to the instrument cluster indicating that the air filter needs to be replaced. This system is calibrated for the OEM intake system and air filter and will not be accurate when K&N products are in use. Always refer to WWW.KNFILTERS.COM for K&N air filter service procedures. The "Air Filter Monitor" system must be disabled to prevent the monitor from setting on and causing a factory dealership visit to rest the system. Follow the "Air Filter Monitor" system procedure listed in the factory owners manual.

30. It will be necessary for all K&N® high flow intake systems to be checked periodically for realignment, clearance and tightening of all connections. Failure to follow the above instructions or proper maintenance may void warranty.

ROAD TESTING:

1. Start the engine with the transmission in neutral or park, and the parking brake engaged. Listen for air leaks or odd noises. For air leaks secure hoses and connections. For odd noises, find cause and repair before proceeding. This kit will function identically to the factory system except for being louder and much more responsive.

2. Test drive the vehicle. Listen for odd noises or rattles and fix as necessary.

3. If road test is fine, you can now enjoy the added power and performance from your kit.

4. K&N Engineering, Inc., requires cleaning the intake system's air filter element every 100,000 miles. When used in dusty or off-road environments, our filters will require cleaning more often. We recommend that you visually inspect your filter once every 25,000 miles to determine if the screen is still visible. When the screen is no longer visible some place on the filter element, it is time to clean it. To clean and re-oil, purchase our filter Recharger® service kit, part number 99-5050 or 99-5000 and follow the easy instructions.

NOT LEGAL FOR SALE OR USE ON ANY POLLUTION CONTROLLED MOTOR VEHICLE IN CALIFORNIA OR STATES ADOPTING CALIFORNIA EMISSION PROCEDURES.

See knfilters.com for CARB status on each part for a specific vehicle