



TYPHOON INTAKE SYSTEMS

SOME INTAKE SYSTEMS ARE NOT LEGAL FOR SALE OR USE ON ANY POLLUTION CONTROLLED MOTOR VEHICLE IN CALIFORNIA OR STATES ADOPTING CALIFORNIA EMISSION PROCEDURES.

See knfilters.com for CARB status on each part for a specific vehicle

INSTALLATION INSTRUCTIONS

69-8608TFK

SCION

2005-06 tc

L4-2.4L

NOTE: C.A.R.B. EO# D-269-32
Applies to 2005-06 model years only

TOOLS NEEDED:

- Phillips head screwdriver
- Flat head screwdriver
- Short Extension
- Needle nose pliers
- 10mm wrench
- 10mm socket
- 3mm allen
- 4mm allen
- Ratch

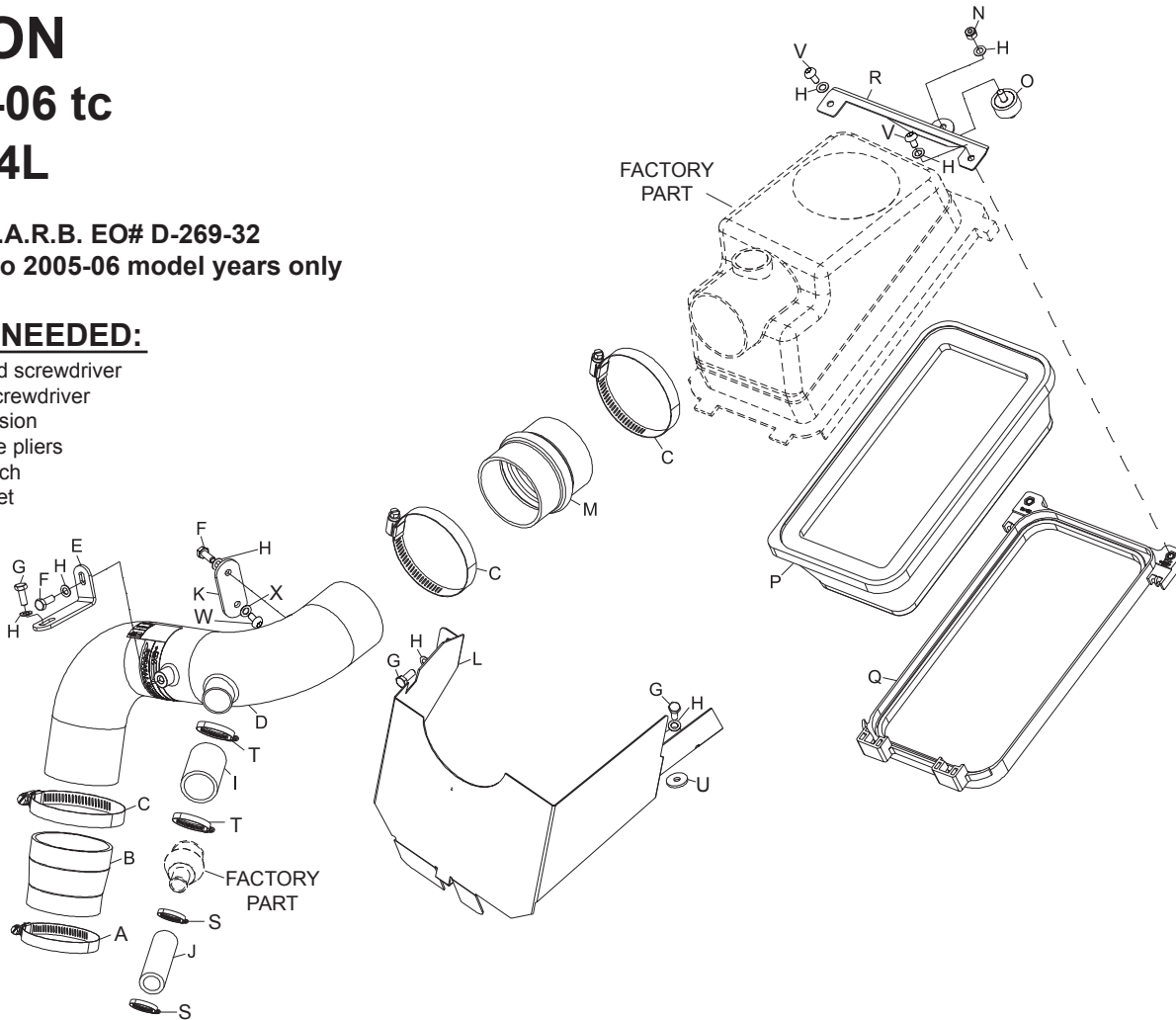

PARTS LIST:

	Description	Qty.	Part #
A	Hose Clamp, #40	1	08554
B	Hose 2-1/2" to 2-3/4" TPRD	1	084016
C	Hose Clamp, #44	3	08560
D	Intake Tube	1	27161
E	Bracket "L"	1	070742
F	Bolt M6 x 1.00 x 12MM Hex	2	07727
G	Bolt 6MM-1.00 x 16MM Hex	3	07812
H	Washer 6MM Wave	8	08277
I	Hose 1-1/8" ID x 2"L Silicone	1	084074
J	Hose 5/8" ID x 3"L Silicone	1	08464
K	Bracket Flat	1	070005
L	Heat Shield	1	07346
M	Hose 2-3/4" ID x 3"L Hump	1	08439
N	Nut Nylock 6MM	1	07512
O	Rubber Mounted Stud	1	07027
P	Air Filter	1	E-3038
Q	Cage, Filter	1	20195
R	Bracket, Filter Mounting	1	020018
S	Hose Clamp #8 Mini	2	08410
T	Hose Clamp #16 Mini	2	08427
U	Rubber Washer	1	21685
V	Bolt M6 x 1.00 x 12MM Button	2	07794
W	Bolt M5 x .8 x 8MM Button	1	07740
X	Flat Washer	1	08212

NOTE: FAILURE TO FOLLOW INSTALLATION INSTRUCTIONS AND NOT USING THE PROVIDED HARDWARE MAY DAMAGE THE INTAKE TUBE, THROTTLE BODY AND ENGINE.

TO START:

- Turn off the ignition and disconnect the negative battery cable.
NOTE: Disconnecting the negative battery cable erases pre-programmed electronic memories. Write down all memory settings before disconnecting the negative battery cable. Some radios will require an anti-theft code to be entered after the battery is reconnected. The anti-theft code is typically supplied with your owner's manual. In the event your vehicles' anti-theft code cannot be recovered, contact an authorized dealership to obtain your vehicles anti-theft code.



- Remove the engine cover, which is secured by two acorn nuts as shown.

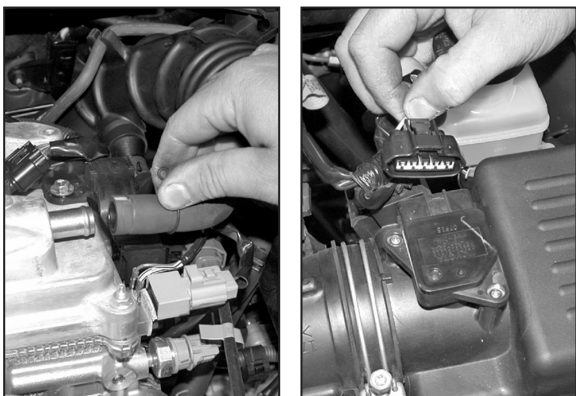

- Disconnect the crankcase vent hose from the valve cover as shown. Then disconnect the mass air sensor electrical connection as shown.



- Detach the wire harness from the air cleaner assembly as shown.

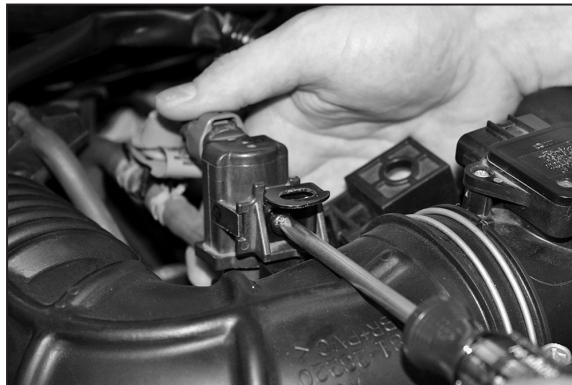

- Detach the vacuum switching valve from the stock intake tube.



- Detach the vent hose from the stock intake tube as shown.



- Release the two retaining clips that secure the air cleaner cover. Depress the spring clamp on the stock intake tube at the throttle body, then, remove the complete upper air intake assembly as shown.



- Loosen and remove the three bolts that retain the lower air cleaner as shown.



- Remove the lower air cleaner assembly as shown.



10. Remove the air inlet duct by rotating it counter clockwise as shown.

NOTE: This will not be reused.

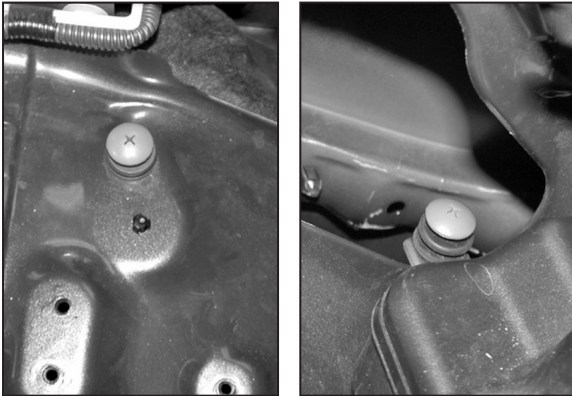

11. Remove the air inlet duct retaining screws from the inner fender as shown.

NOTE: These will not be reused.

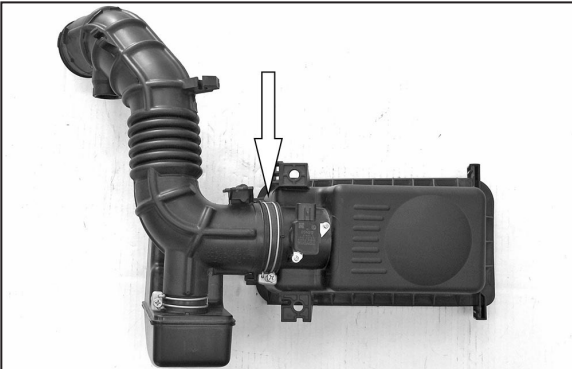

12. Loosen the hose clamp, disconnect the stock intake tube from the air cleaner cover.



13. Remove the bolt that retains the wire harness bracket to the transmission mount.

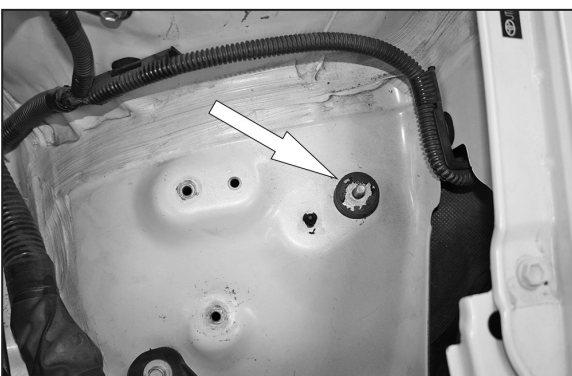

14. Install the rubber mounted stud provided into the threaded hole in the inner fender apron as shown.

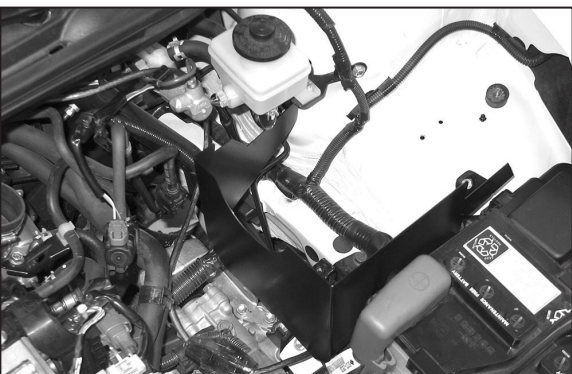

15. Using the provided hardware fasten the heat shield to the threaded hole on the strut tower.

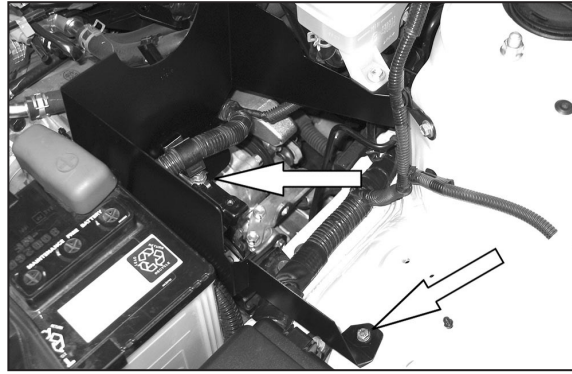

16. Using the bolt removed in step 13, fasten the heat shield & wire harness bracket, then resecure bolt. With the provided hardware secure the heat shield to the factory air cleaner mounting point located on the inner fender apron.

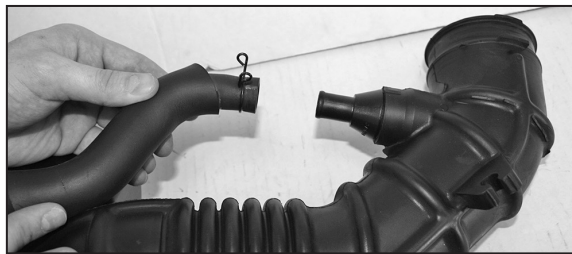

17. Disassemble the crankcase vent hose, union tube and stock intake tube as shown.

NOTE: The intake tube and vent hose will not be reused.

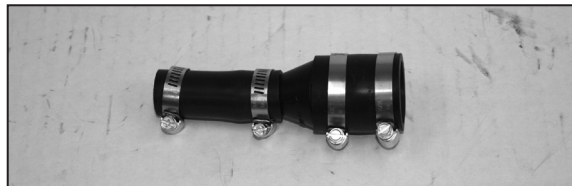

18. Assemble the two silicone hoses and the union tube, place the hose clamps as shown.

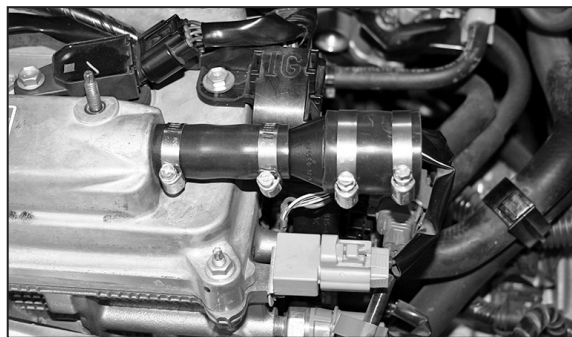

19. Connect the crankcase vent assembly to the vent fitting on the valve cover.



20. Using the hose clamps provided, install the tapered hose with clamps onto the throttle body as shown.



21. Using the hardware provided, attach the "L" bracket to the threaded hole located on the rear portion of the valve cover as shown.



22. Install the hump hose onto the K&N® intake tube with the hose clamps provided.



23. Install the K&N® intake tube inserting it into the tapered hose at the throttle body.



24. Connect the crankcase vent assembly to the vent fitting on the K&N® intake tube and tighten all hose clamps.

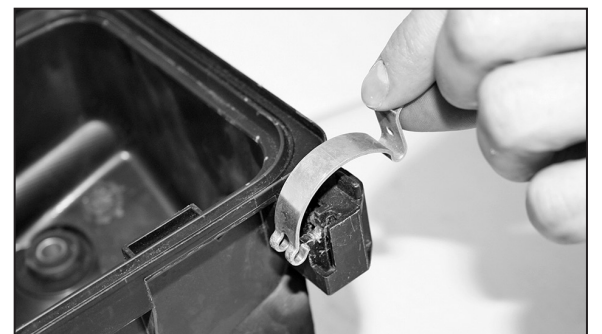

25. Remove the two retaining clips from the lower air cleaner by pushing down as shown.

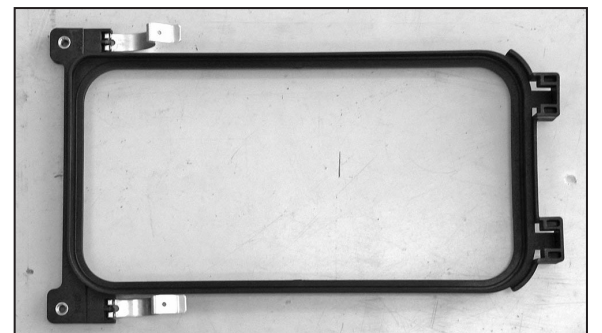

26. Attach the retaining clips removed in the previous step to the pins located on the filter cage.

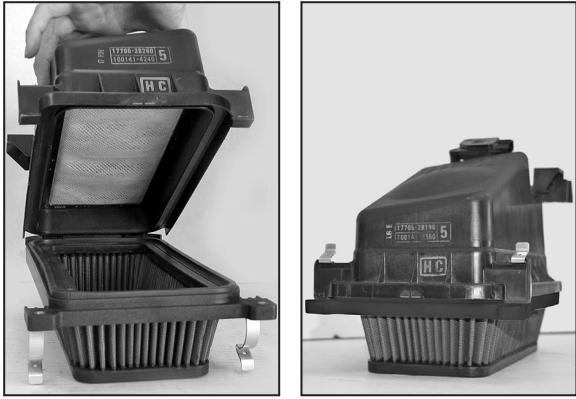

27. Assemble the K&N® filter, filter cage and stock upper air cleaner cover. Fasten the retaining clips to the stock air cleaner cover as shown.

NOTE: DO NOT TAMPER WITH THE STOCK HC FILTER AS THIS WILL VOID WARRANTY AND STREET LEGAL STATUS.

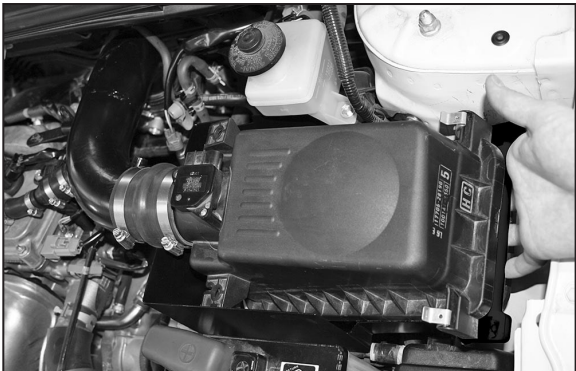

28. Install the K&N® filter assembly into the hump hose at the K&N® intake tube.



29. Using the provided hardware, fasten the filter assembly mounting bracket to the threaded inserts in the filter cage, then to the rubber mounted stud located on the inner fender apron.

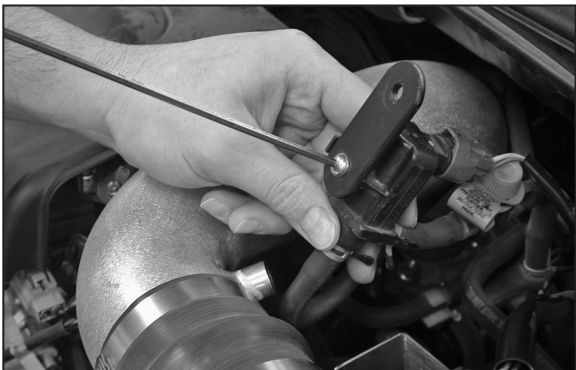

30. Attach the flat bracket to the vacuum switching valve using the a buttonhead screw.

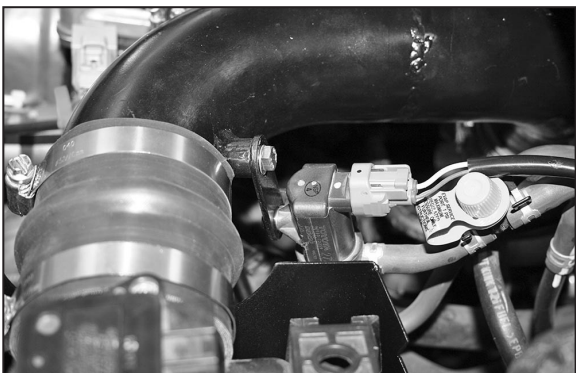

31. Fasten the vacuum switching valve assembly to the threaded boss on the K&N® intake tube, using the provided hardware.

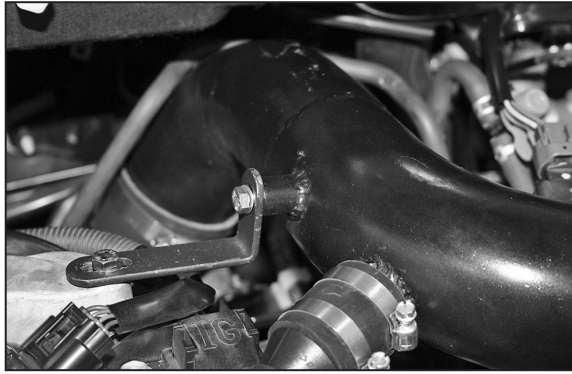

32. Using the hardware provided, fasten the "L" bracket to the threaded boss on the K&N® intake tube as shown.

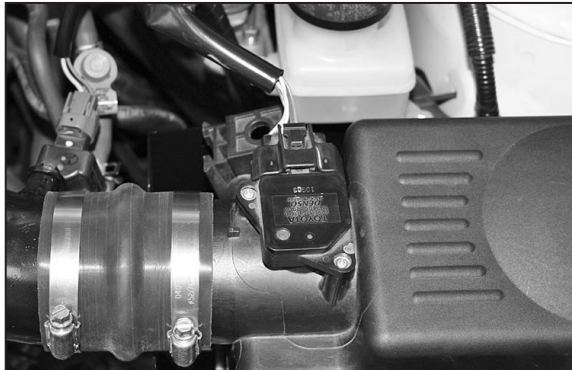

33. Reconnect the mass air sensor electrical connection. Check everything for best fit and clearance then tighten all hardware and hose clamps.



34. Reinstall the engine cover and acorn nuts that were removed in step #2 as shown.



35. Reconnect the vehicle's negative battery cable. Double check to make sure everything is tight and properly positioned before starting the vehicle.

36. The C.A.R.B. exemption sticker, (attached), must be visible under the hood so that an emissions inspector can see it when the vehicle is required to be tested for emissions. California requires testing every two years, other states may vary.

37. It will be necessary for all K&N® high flow intake systems to be checked periodically for realignment, clearance and tightening of all connections. Failure to follow the above instructions or proper maintenance may void warranty.

ROAD TESTING:

1. Start the engine with the transmission in neutral or park, and the parking brake engaged. Listen for air leaks or odd noises. For air leaks secure hoses and connections. For odd noises, find cause and repair before proceeding. This kit will function identically to the factory system except for being louder and much more responsive.

2. Test drive the vehicle. Listen for odd noises or rattles and fix as necessary.

3. If road test is fine, you can now enjoy the added power and performance from your kit.

4. K&N Engineering, Inc., requires cleaning the intake system's air filter element every 100,000 miles. When used in dusty or off-road environments, our filters will require cleaning more often. We recommend that you visually inspect your filter once every 25,000 miles to determine if the screen is still visible. When the screen is no longer visible some place on the filter element, it is time to clean it. To clean and re-oil, purchase our filter Recharger® service kit, part number 99-5050 or 99-5000 and follow the easy instructions.

SOME INTAKE SYSTEMS ARE NOT LEGAL FOR SALE OR USE ON ANY POLLUTION CONTROLLED MOTOR VEHICLE IN CALIFORNIA OR STATES ADOPTING CALIFORNIA EMISSION PROCEDURES.

See knfilters.com for CARB status on each part for a specific vehicle