



INTAKE SYSTEMS FOR VEHICLES LISTED ARE 50 STATE LEGAL. SEE KNFILTERS.COM FOR CARB STATUS ON EACH PART FOR A SPECIFIC VEHICLE.

INSTALLATION INSTRUCTIONS

71-2584 FORD 2011-12 F150 V8-6.2L

NOTE: This kit was not designed to fit vehicles with a body lift.

TOOLS NEEDED:

Ratchet,
Extension
10mm socket
Flat blade screw driver
3/4" wrench
9/16" wrench
4mm Allen wrench
3mm Allen wrench
T20 Torx.

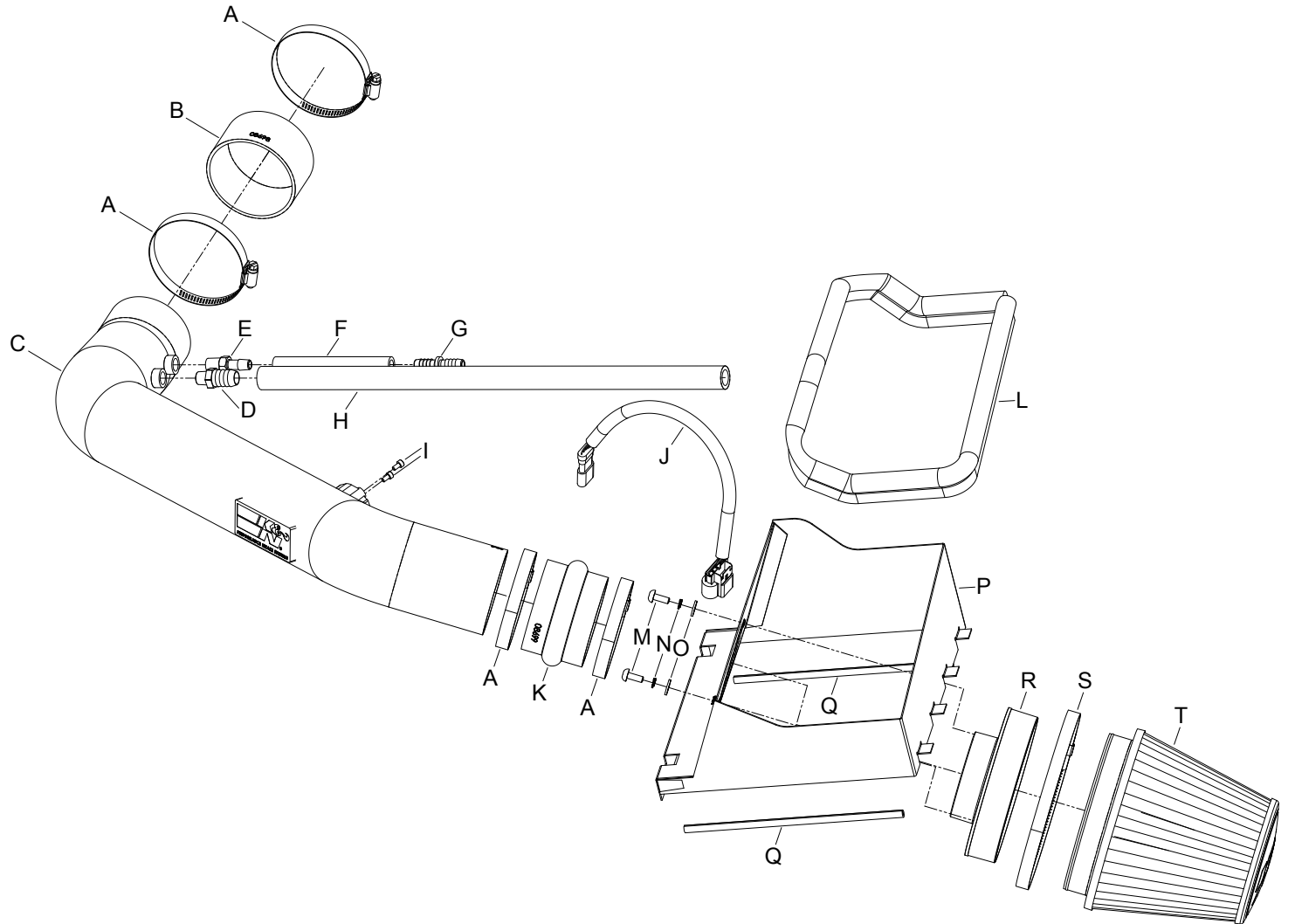

PARTS LIST:

Description	Qty.	Part #	Description	Qty.	Part #	Description	Qty.	Part #
A HOSE CLAMP; #56 BLK ZINC	4	08620KA	H HOSE; 5/8"ID X 20"L	1	08542	O WASHER; 1/4"ID X 5/8"OD	2	08275
B HOSE; 3.5"ID X 2"L	1	08698	I BOLT; M4-.7 X 8MM, ALNHD	2	07733	P HEAT SHIELD	1	074076A
C INTAKE TUBE; 3.5"OD X 31"L	1	27590TK	J MAF EXTENSION HARNESS	1	21780	Q EDGE TRIM; (19"L)	1	102451
D VENT; 1/4"NPT, 5/8"BARB	1	82638	K HOSE; HUMP 3.5"ID X 2.5"L	1	08699	R ADAPTER; 6" FILTER	1	21512-1
E VENT; 3/8"HOSE, 1/4"NPT	1	08047	L EDGE TRIM; (35"L)	1	102471	S HOSE CLAMP; #104 BLK ZINC	1	08697KA
F HOSE; 3/8"ID X 5"L	1	08717	M BOLT; M6 X 1 X 16MM, BTNHD	2	07730	T AIR FILTER	1	RU-3102HBK
G VENT; STRT, 3/8" HOSE	1	08041	N WASHER; M6 SPLIT LOCK	2	1-3025			

If you need any assistance please call 1-800-858-3333 to speak with a representative in our Customer Service Center before returning the product.

NOTE: FAILURE TO FOLLOW INSTALLATION INSTRUCTIONS AND NOT USING THE PROVIDED HARDWARE MAY DAMAGE THE INTAKE TUBE, THROTTLE BODY AND ENGINE.

TO START:

1. Turn off the ignition and disconnect the negative battery cable.

NOTE: Disconnecting the negative battery cable erases pre-programmed electronic memories. Write down all memory settings before disconnecting the negative battery cable. Some radios will require an anti-theft code to be entered after the battery is reconnected. The anti-theft code is typically supplied with your owner's manual. In the event your vehicles' anti-theft code cannot be recovered, contact an authorized dealership to obtain your vehicles anti-theft code.



2. Disconnect the mass air sensor electrical connection.



3. Loosen the hose clamp that secures the factory intake tube to the intake plenum.



4. Release the three upper air box retaining clips.



5. Remove the upper air box/intake hose assembly from the vehicle.

NOTE: K&N Engineering, Inc., recommends that customers do not discard factory air intake.



6. Remove the two bolts that secure the intake plenum.



7. Disconnect the crank case vent hose from the valve cover port.



8. Disconnect the EVAP vent line from the intake plenum.



9. Loosen the hose clamp securing the intake plenum to the throttle body and then remove the intake plenum from the vehicle.



10. Install the provided coupling hose (08698) onto the throttle body and secure with the provided hose clamp.

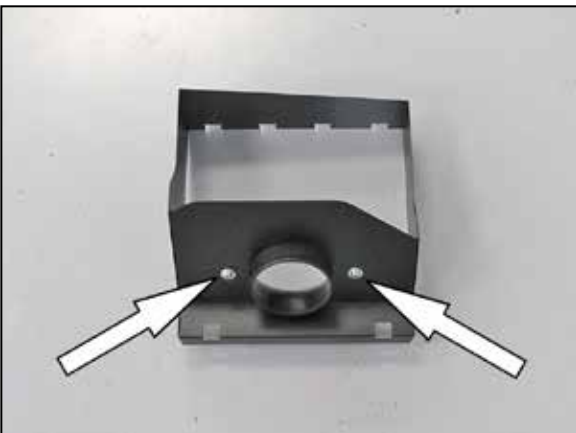

11. Install the filter adapter into the K&N® heat shield and secure with the provided hardware.



12. Cut the provided small edge trim into two sections of 9".

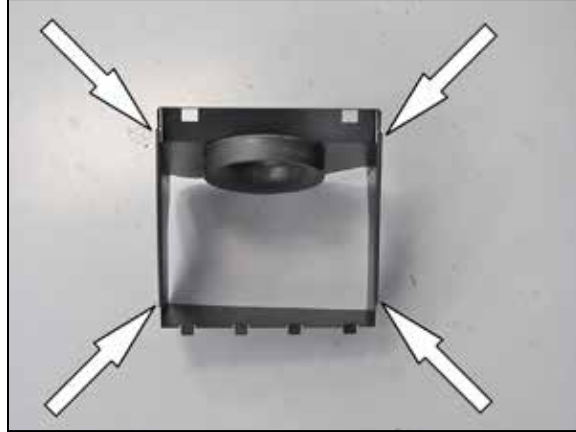

13. Install the cut sections of edge trim onto the bottom of the heat shield as shown.

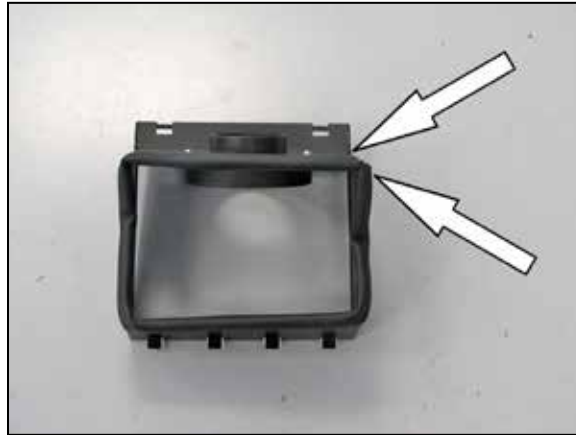

14. Install the provided "Top Bulb" edge trim onto the top of the heat shield as shown.
NOTE; Some trimming of the edge trim will be necessary.



15. Install the K&N® air filter onto the adapter and secure with the provided hose clamp.



16. Remove the center upper air box retaining clip.



17. Set the heat shield assembly onto the lower air box and secure with the two remaining air box clips.



18. Install the provided hump coupler (08699) onto the filter adapter and secure with the provided hose clamp.



19. Remove the two screws securing the mass air sensor into the air box and then remove the sensor.



20. Install the mass air sensor into the K&N® intake tube and secure with the provided hardware.



21. Install the two provided NPT vent fittings into the K&N® intake tube as shown.
NOTE: NPT fitting has tapered threads and only designed to be installed until hand tight, then tighten one rotation or when the fitting becomes difficult to return.



22. Install the K&N® intake tube into the hump hose at the filter adapter and then into the hose at the throttle body, adjust the tube for proper fit and then secure with the provided hose clamps.



23. Install the provided hose mender into the provided EVAP hose and then install the hose mender into the factory EVAP hose. Connect the open end onto the fitting installed into the K&N® intake tube.



24. Install the provided crank case vent hose onto the valve cover port and then onto the fitting installed into the K&N® intake tube.



25. Connect the provided mass air sensor extension harness into the factory harness and then connect the open end to the mass air sensor.



26. Reconnect the vehicle's negative battery cable. Double check to make sure everything is tight and properly positioned before starting the vehicle.

27. The C.A.R.B. exemption sticker, (attached), must be visible under the hood so that an emissions inspector can see it when the vehicle is required to be tested for emissions. California requires testing every two years, other states may vary.

28. It will be necessary for all K&N® high flow intake systems to be checked periodically for realignment, clearance and tightening of all connections. Failure to follow the above instructions or proper maintenance may void warranty.

ROAD TESTING:

1. Start the engine with the transmission in neutral or park, and the parking brake engaged. Listen for air leaks or odd noises. For air leaks secure hoses and connections. For odd noises, find cause and repair before proceeding. This kit will function identically to the factory system except for being louder and much more responsive.

2. Test drive the vehicle. Listen for odd noises or rattles and fix as necessary.

3. If road test is fine, you can now enjoy the added power and performance from your kit.

4. K&N Engineering, Inc., requires cleaning the Blackhawk Induction™ intake system's air filter element every 50,000 miles. When used in dusty or off-road environments, our filters will require cleaning more often. We recommend that you visually inspect your filter once every 25,000 miles to determine if the screen is still visible. When the screen is no longer visible some place on the filter element, it is time to clean it. To clean, purchase our Synthetic Filter Cleaner, part number 99-0624 and follow the easy instructions.

INTAKE SYSTEMS FOR VEHICLES LISTED ARE 50 STATE LEGAL. SEE KNFILTERS.COM FOR CARB STATUS ON EACH PART FOR A SPECIFIC VEHICLE.