



Oil Separator INSTALLATION INSTRUCTIONS

81-0803

DODGE / JEEP

2018 Demon 6.2L

2021 Durango Hellcat 6.2L

2015-23 Hellcat 6.2L

2018-21 Trackhawk

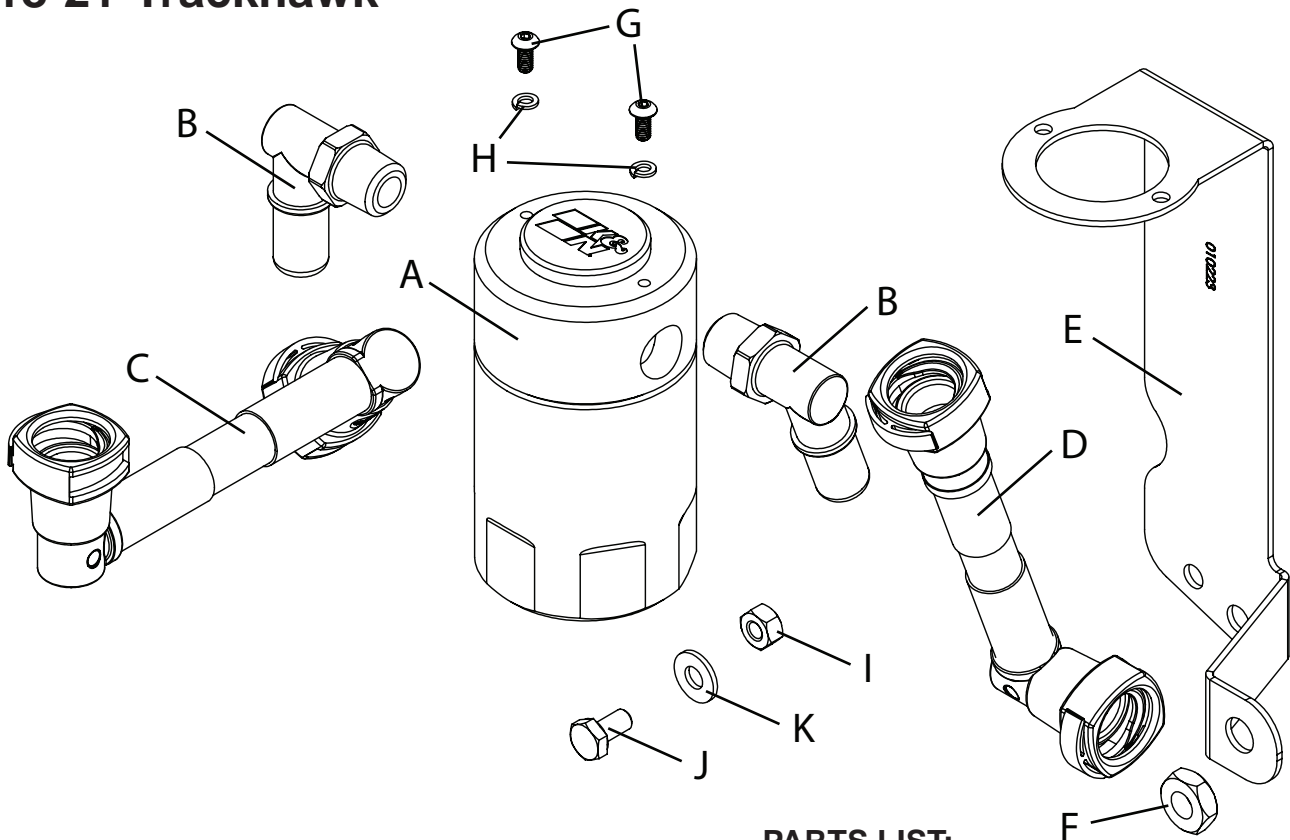

PARTS LIST:

	Description	Qty.	Part #
A	CATCH CAN; 2.5"OD X 4.5"H	1	85-6860
B	QUICK RELEASE; 3/8" NPT	2	082634
C	HOSE; 1/2"ID X 3.5"L	1	084147
D	HOSE; 1/2"ID X 3.125"L	1	084147
E	BRACKET	1	010223
F	M10 NUT	1	07508
G	8-32 X 3/8; BTNHD HEX	2	91255A192
H	18-8 SPLIT LOCK WASHER	2	92146A618
I	1/4-20 NUT	1	07519
J	1/4-20 x 1/2" BTNHD BOLT	1	07706
K	1/4" x 5/8" FLAT WASHER	1	08275

TOOLS NEEDED:

- 2.5mm Allen key
- 1/2" Wrench
- 17mm Wrench
- 13/16" Wrench

1. Verify you have all the parts included in the kit.

2. Remove valve cover by gently pulling upward.



3. Remove factory PCV line by pulling tabs and removing it from the PCV valve and intake manifold

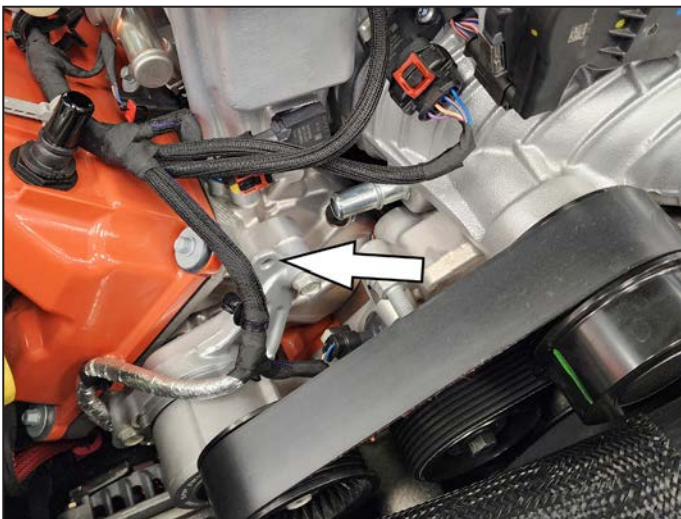

4. Remove factory wire harness holder by gently pulling towards the front of the vehicle.



5. Mount the bracket by using the existing M10 below intake manifold connection using supplied nut. Use 1/4-20 hex head bolt, washer and nut through middle hole where wire harness holder is as shown.



6. Plug wire harness holder in hole on the bracket.



10. We recommend to check the oil separator every 10,000 miles or 12 months (sooner if vehicle is driven in harsher conditions such as towing or off-road).

7. Assemble the quick disconnect fittings to the top of the air/oil separator. It is required to use Teflon tape on the fittings to ensure a proper seal. **NOTE: DO NOT over-tighten fittings in top of oil separator.** Mount the canister to the bracket using the two button head screws and lock washers.



8. Install hose with straight quick disconnect between intake manifold and canister. Mount hose with two 90 degree quick disconnects between the valve cover and canister.

NOTE: Lightly coat the O-Ring with oil to insert easily.

9. Install valve cover.