



QUALITY... PLAIN & SIMPLE®

U-Cut-to-Fit Ford Speedometer Cable Kit Installation Instructions

General Installation Notes:

Please read these instructions completely before beginning the installation. If you have any questions, please call.

Before beginning the installation, disconnect the negative battery cable and use wheel chocks to block the vehicle's wheels.

Make sure the engine, transmission, body and frame are properly grounded. We recommend using anti-seize lubricant on all aluminum threads.

Refer to Fig. 1 and Fig. 2 for the component names.

Do not remove the anti-seize compound that has been applied to the threads on the trans end fitting.

Step 1: Remove the inner wire from the cable housing on the new Lokar Speedometer Cable.

Step 2: Temporarily install the cable housing onto the speedometer. Route the cable housing to the transmission, making sure to keep it away from the exhaust. Do not make any sharp bends when routing the cable housing.

Step 3: It will be necessary to shorten the new cable housing. Mark the cable housing where it lines up with the speedometer cable connection on the transmission. Disconnect the cable housing from the speedometer and remove the cable housing from the vehicle.

Unscrew the compression nut from the trans end fitting. Pull the trans end fitting off of the cable housing, being careful not to damage it. **Do not remove the compression nut from the cable housing.** Slide the compression nut towards the speedometer end of the cable housing, away from the transmission.

Make sure that the inner wire is removed from the cable housing. If the Speedometer Cable has the braided stainless steel housing, wrap tape around the area to be cut and use a cutoff wheel or fine-toothed hacksaw to cut the cable housing at your mark. If the Speedometer Cable has the black universal housing, cut the cable housing at your mark using heavy duty 8" diagonal cutting pliers or a hacksaw. Lokar recommends Klein brand Diagonal Cutting Pliers, # D2000-28 available at The Home Depot or through W. W. Graingers, Part # 4A838.

Step 4: After cutting the cable housing, re-install the trans end fitting onto the end of the cable housing. Make sure the cable housing is pushed all the way in to the trans end fitting, until it is bottomed out. Thread the compression nut onto the trans end fitting and tighten it until the cable housing is locked into the trans end fitting. **DO NOT assemble the trans end fitting until after the cable housing has been cut to length!**

U-Cut-to-Fit Ford Speedometer Cable Kit Installation Instructions

Building American Quality... With A Lifetime Warranty!®

TOLL FREE 1-877-469-7440 • tech@lokar.com • www.lokar.com

Note: Do not over tighten the compression nut!

Step 5: Install the provided o-ring into the groove on the trans end fitting. Install the inner wire into the cable housing with the square end towards the transmission. Install your original speedometer gear (not included) and gear retaining clip (not included) onto the trans end fitting, with the lip on the retaining clip pointing away from the transmission. **Fig. 3** Make sure the speedometer gear spins freely. Push the inner wire fully into the speedometer gear, twisting it as you go. When the inner wire is seated in the speedometer gear, the gear will turn if you twist the inner wire at the speedometer end.

Step 6: Lubricate the o-ring with a light coat of the oil or fluid that is correct for your transmission, and install the trans end fitting into the transmission. Install the hold down clip using the provided 1/4"-20 x 3/4" button head bolt and lock washer. **Fig. 4**

Step 7: Route the cable housing back up to the speedometer. At the speedometer head, mark the inner wire flush with the end of the speedometer end fitting. **Fig. 5** Remove the inner wire from the cable housing.

Step 8, All Speedometers EXCEPT Early Ford: Measure 5/16" back towards the transmission from your mark, and cut the inner wire there. **Fig. 6**

Step 8, 1948 & Earlier Ford Speedometers: Measure 9/16" back towards the transmission from your mark, and cut the inner wire there. **Fig. 6**

Step 9: De-burr the end of the inner wire. Insert the inner wire as far as it will go into the cable tip. Insert the cable tip into the crimping die, making sure it is pushed all the way in.

To crimp the cable tip, squeeze the crimping die in a vise. Make sure the crimping die is positioned in the vise so that the cable tip is between the vise jaws, not above them. **Fig. 7**

Step 10: Remove the crimping die by prying it apart with a screwdriver.

Step 11: Lubricate the inner wire with a light coat of the supplied silicone grease. Install the inner wire into the cable housing, making sure it bottoms out in the speedometer gear. It will likely be necessary to rotate the inner wire slightly in order to get it to align with the speedometer gear and slide all the way in.

Connect the new Speedometer Cable to the speedometer. **Fig. 8 & Fig. 9**

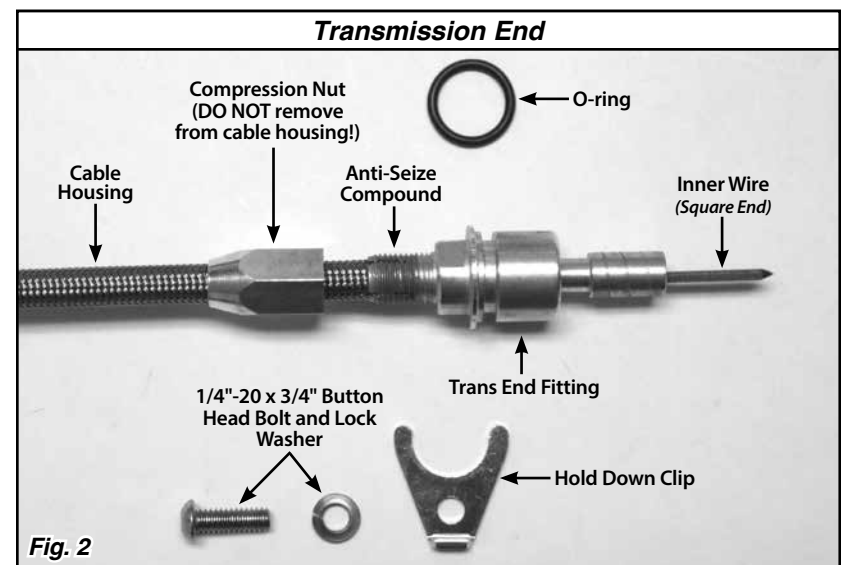
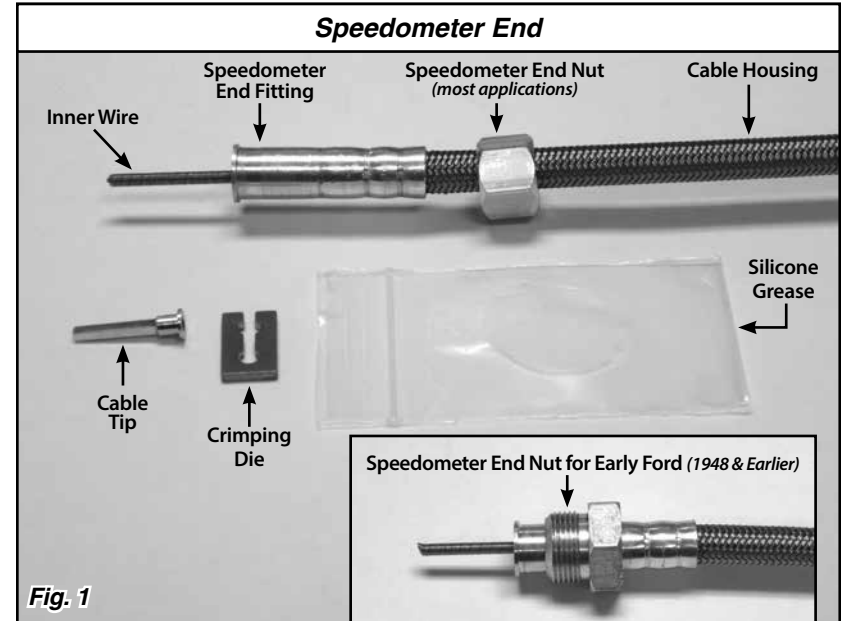

U-Cut-to-Fit Ford Speedometer Cable Kit Installation Instructions

Transmission End, Assembled

NOTE: You MUST cut the Cable Housing to length BEFORE assembling!

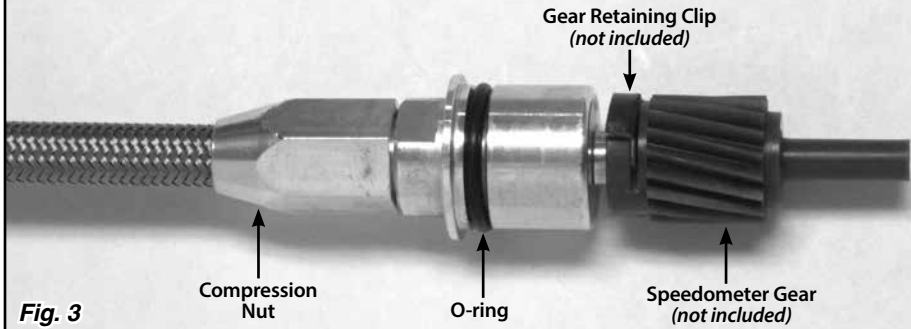

Fig. 3

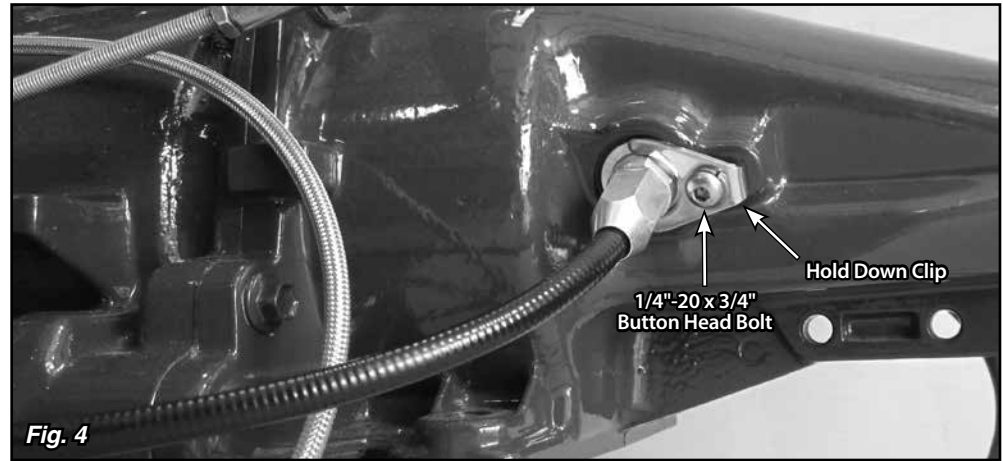

Fig. 4

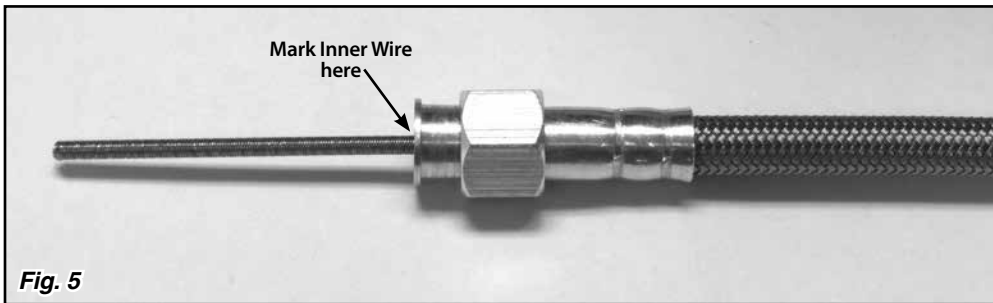

Fig. 5

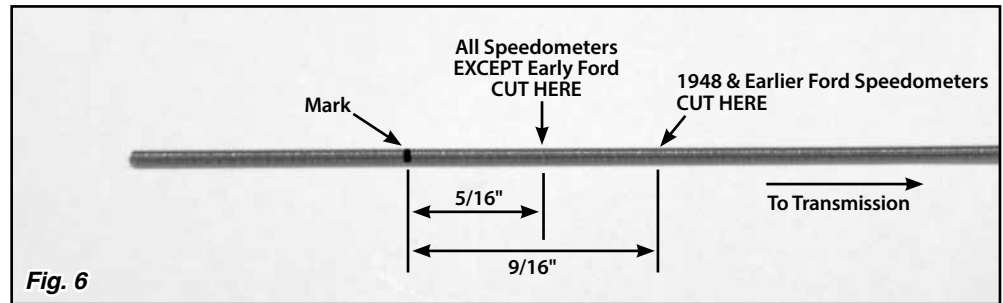

Fig. 6

Squeeze Crimping Die with Vise

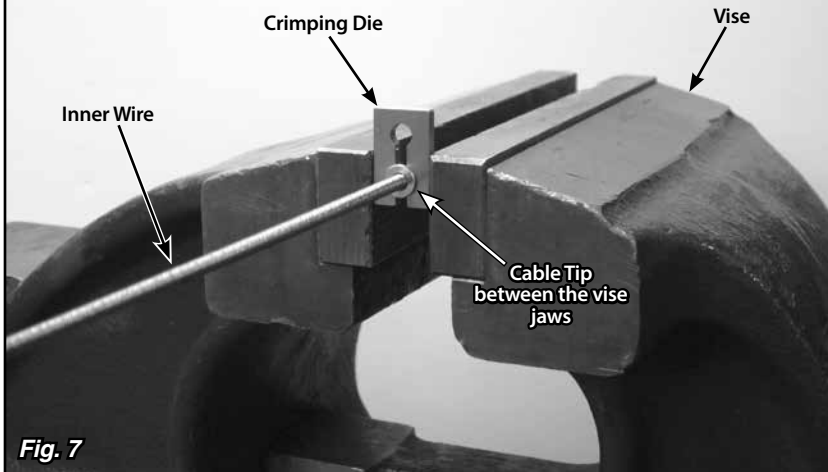

Fig. 7

All EXCEPT Early Ford Speedometer

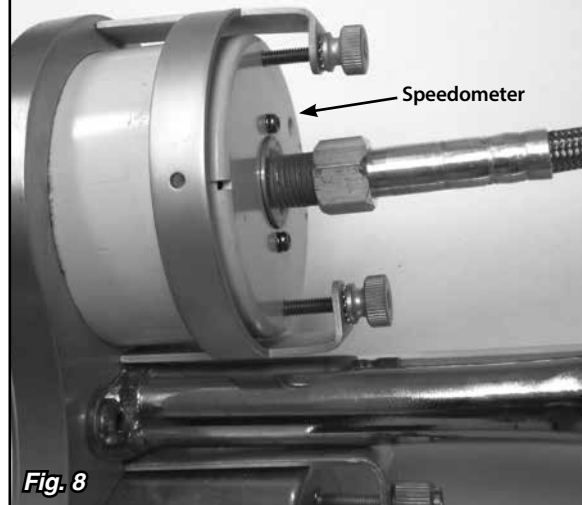

Fig. 8

1948 & Earlier Ford Speedometer

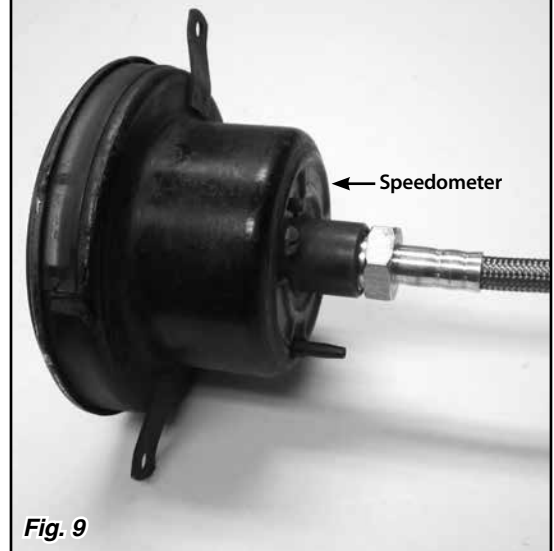

Fig. 9