



QUALITY... PLAIN & SIMPLE®

Throttle Pedal Assembly Installation Instructions

For 1955-57 Chevy, 1961-64 Impala, 1964-72 Chevelle, 1967-81 Camaro/Firebird, and 1968-72 Nova

General Installation Notes:

Please read these instructions completely before beginning the installation. If you have any questions, please call.

Before beginning the installation, disconnect the negative battery cable and use wheel chocks to block the vehicle's wheels.

Make sure the engine, transmission, body and frame are properly grounded. We recommend using anti-seize lubricant on all aluminum threads.

All Lokar Installation Instructions can be found by visiting www.lokar.com/instructions.html.

The Lokar Throttle Pedal is designed for use with Lokar Throttle Cables. Stock style cables will not work. If your vehicle has an automatic transmission, installation of a Lokar Kickdown Kit (if applicable) is strongly recommended. Lokar Throttle Cables and Kickdown Kits are application-specific according to the type of induction system and the transmission model.

1955-57 Chevy with big block OR small block with tall valve covers: Lokar has Throttle Pedals available that have a longer billet upper arm (5-13/16" center-to-center distance) to prevent interference between the engine and the Throttle Cable.

Refer to Fig. 1 and Fig. 2 for the component names.

Step 1: Remove any existing throttle pedal assembly and linkage components.

Step 2: Disassemble the Lokar Throttle Pedal by removing the 1/4"-20 x 1/2" flat head bolt (Fig. 3, #1) from the end of the mounting shaft (Fig. 3, #14) or mounting block. Slide the billet upper and lower arms off of the mounting shaft or block.

Step 3: All with Mounting Shaft: Install the mounting shaft into the firewall from the engine compartment side using the stock hole where the original throttle linkage was mounted. Use the original hardware to attach the mounting shaft to the firewall. If your original hardware is missing, the mounting shaft is designed to accept 1/4" diameter bolts and nuts. Fig. 4

All with Mounting Block: Install the mounting block onto the firewall from the passenger compartment side, in the same position as the original. The 1970-81 Camaro/Firebird mount block is threaded for 1/4"-20 bolts (not included). The 1968-72 Chevelle mount block is not threaded, but is designed to accept 1/4" diameter bolts and nuts (not included).

Throttle Pedal Assembly Installation Instructions

For 1955-57 Chevy, 1961-64 Impala, 1967-81 Camaro/Firebird, 1964-72 Chevelle, and 1968-72 Nova

Building American Quality... With A Lifetime Warranty!®

TOLL FREE 1-877-469-7440 • tech@lokar.com • www.lokar.com

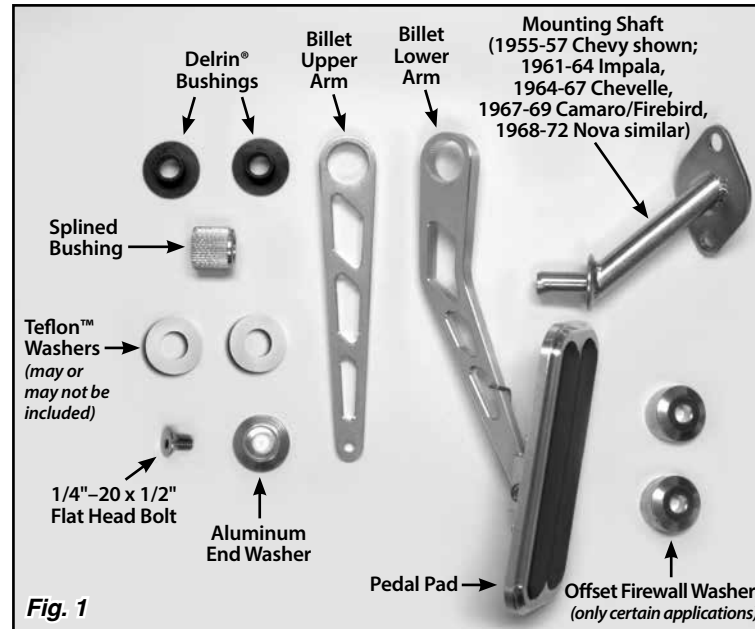


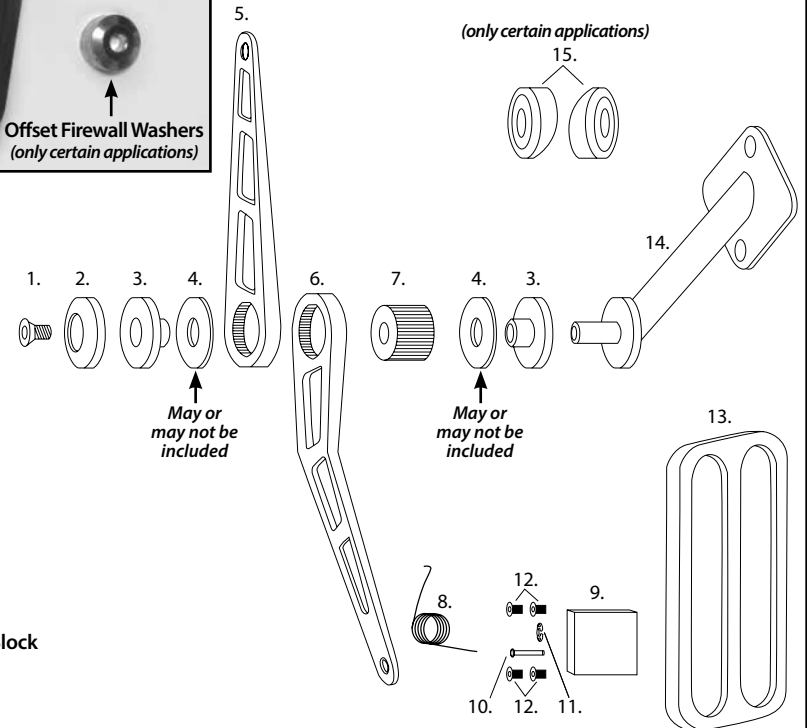
Fig. 1

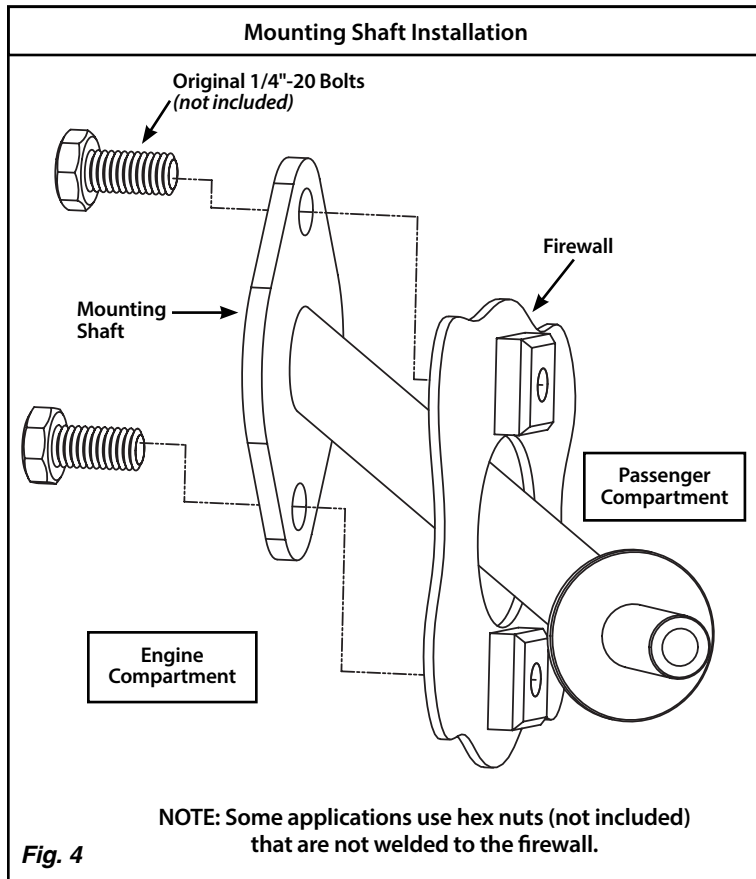


Fig. 2

1. 1/4"-20 x 1/2" Flat Head Bolt
2. Aluminum End Washer
3. Delrin® Bushing
4. Teflon™ Washer (May or may not be included)
5. Billet Upper Arm
6. Billet Lower Arm
7. Splined Bushing
8. Stainless Pedal Pad Spring
9. Gas Pedal Back
10. Stainless Pedal Pad Pin
11. 3/16" Stainless E-Clip
12. #8-32 x 3/16" Button Head Bolt
13. Pedal Pad
14. Mounting Shaft - OR - Mounting Block
15. Offset Firewall Washers (only certain applications)

Fig. 3





Step 4: Reassemble the Lokar Throttle Pedal with the billet lower arm (**Fig. 3, #6**) pointing down and the billet upper arm (**Fig. 3, #5**) pointing up. The billet upper and lower arms can be switched left to right if needed for clearance purposes. Reinstall the 1/4"-20 x 1/2" flat head bolt and aluminum end washer onto the end of the shaft. Verify the pedal still rotates freely.

Step 5: Push the billet upper arm forward so it is parallel to the firewall. Mark the firewall in line with the 3/16" hole on the end of the billet upper arm. Drill a 5/16" diameter hole through the firewall for the Lokar Throttle Cable fitting to mount into.

Note: If your Lokar Throttle Pedal came with two offset firewall washers (**Fig. 3, #15**) and you have a stock, unmodified firewall, the offset washers will need to be installed on the firewall (one inside and one outside) and rotated to allow the Throttle Cable to go straight through the firewall on your vehicle.

Step 6: Install the Lokar Throttle Cable according to the instructions supplied with the Throttle Cable. You may have to reposition the billet upper arm on the Throttle Pedal in order to get the Throttle Cable adjusted correctly. Make sure there is no binding in the throttle linkage and the throttle returns to the closed position when it is released.

See **Fig. 5, 6 and 7** for a finished installation on a shaft-mount pedal. **Fig. 8** shows the mounting block style pedals assembled.

NOTE: Once the Throttle Cable is installed, make sure the Throttle Pedal is completely floored when the throttle is wide open. If the Throttle Pedal is not completely floored at wide open throttle, you will need to either change the position of the billet lower arm on the Throttle Pedal or install a pedal stop.

