



QUALITY... PLAIN & SIMPLE®

## TH350 & TH200 Stainless Kickdown Bracket & Cable Installation Instructions

### General Installation Notes:

Please read these instructions completely before beginning the installation. If you have any questions, please call.

Before beginning the installation, disconnect the negative battery cable and use wheel chocks to block the vehicle's wheels.

Make sure the engine, transmission, body and frame are properly grounded. We recommend using anti-seize lubricant on all aluminum threads.

Refer to Fig. 1 and Fig. 2 for the component names.

**Step 1:** Remove the old kickdown cable (if equipped).

**Step 2:** Route the transmission end of the new Kickdown Cable down towards the passenger side of the transmission, with the engine end of the cable positioned on the driver side of the intake manifold.

**Step 3:** Loosen the two rear bolts on the driver side of the intake manifold.

**Step 4:** Install the kickdown bracket under the bolt heads. If there are washers on the bolts, make sure the kickdown bracket is installed against the intake manifold, underneath the washers. **Fig. 3**

**Step 5:** Tighten the intake manifold bolts to the manufacturer's torque specification.

**Step 6:** Raise the vehicle and support it on jack stands or a vehicle lift.

**Step 7:** Make sure there isn't an old seal in the kickdown cable opening in the transmission. The new cable cannot be installed if the old seal is still in the transmission.

**NOTE:** If you have a TH200 transmission, check the diameter of the kickdown cable opening. Some TH200 transmissions have a larger opening and will need the supplied adapter seal. For a transmission with the larger opening, remove the existing rubber hat seal from the new Kickdown Cable. Install the adapter seal onto the bottom of the Kickdown Cable. The adapter seal has an offset hole, and will need to be rotated to a position that allows the bolt hole in the Kickdown Cable to be aligned with the bolt hole in the transmission case.

**Step 8:** Verify that the correct type of seal is on the transmission end of the cable. Lightly coat the seal with clean transmission fluid. Insert the kickdown hookup rod on the transmission into the hole in the transmission end of the kickdown inner cable. **Fig. 4**

# TH350 & TH200 Stainless Kickdown Bracket & Cable Installation Instructions

Building American Quality... With A Lifetime Warranty!®

TOLL FREE 1-877-469-7440 • tech@lokar.com • www.lokar.com

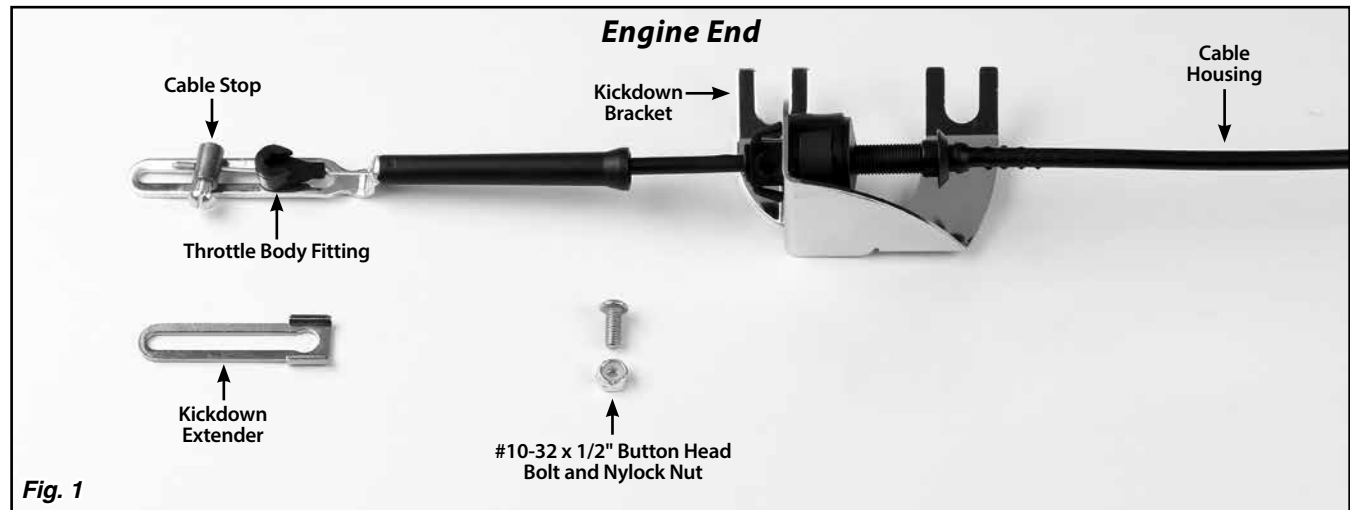

Fig. 1

**Step 9:** Insert the kickdown cable housing with the rubber hat seal (or adapter seal) into the transmission. Re-install the original retaining bolt and tighten it to the factory specification. **Fig. 5** Lower the vehicle.

**Step 10:** At the engine, pull the end of the Kickdown Cable towards the front of the vehicle, enough to be able to slide the enlarged part of the slot over the kickdown stud on the throttle linkage. If the Kickdown Cable will not reach the kickdown stud, you can install the kickdown extender (included). If your throttle arm does not have a kickdown stud, use the #10-32 x 1/2" button head bolt and nylock nut to attach the kickdown cable to the throttle arm. Tighten the nut, then back it off just enough so that the bolt can slide in the slot.

**Step 11:** To adjust the Kickdown Cable, release the latch on the housing by pushing it up from the bottom. **Fig. 6** If you cannot get it to release by hand, you may be able to pry the latch up with a screwdriver. Move the throttle to the wide open position and hold it there. Push the latch back down to lock the cable housing into position.

While still holding the throttle wide open, check for slack in the inner wire by trying to pull it further out of the cable housing. If there is any slack in the inner wire, loosen the screw in the cable stop. With the throttle held wide open, use a pair of pliers to pull all of the slack out of the inner wire. Slide the cable stop as far rearward as it will go on the inner wire, and tighten the screw in the cable stop.

Release the throttle.

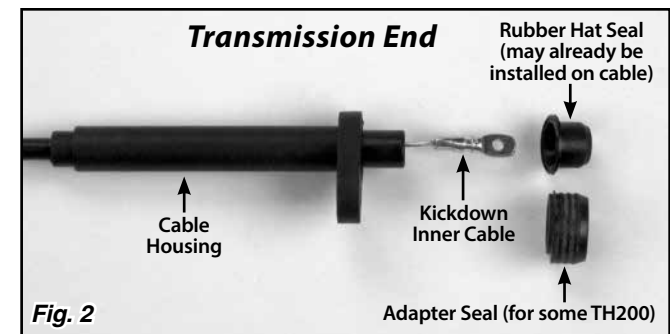

Fig. 2

Continued from Step 11:

The Kickdown Cable is properly adjusted when **both** of the following conditions are met:

- You are able to open the throttle to the wide open position without interference from the Kickdown Cable.
- With the throttle wide open, you are not able to pull the Kickdown Cable out any further.

When the installation is completed, the Kickdown Cable and Bracket should look like **Fig. 7**.

**Step 12:** Double check to be sure that all throttle linkage operates freely without binding and that the pedal returns to the closed position when released.

