

# Installation Instructions

## **LUND**<sup>®</sup> OE Style No Drill Bracket

For proper installation and best possible fit, please read all instructions BEFORE you begin.

**For technical assistance or to obtain missing parts, please call Customer Relations at 1-800-241-7219.**

### Important Safety Information



#### WARNING

- To be used with Lund<sup>®</sup> branded products only.
- Do not stand on Lund running board or bracket while vehicle is in motion.
- Do not exceed 350lbs. weight on the Lund bracket system.
- Do not use the brackets as a jacking point for the vehicle.
- Do not use the bracket system or running boards to fasten cargo.
- Periodically check all components for tightness.



#### CAUTION

- Be sure to wear safety glasses while installing brackets.
- When using power tools, read and understand all operating instructions.

### Contents

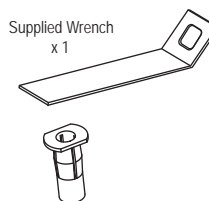
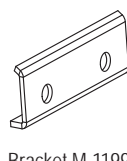
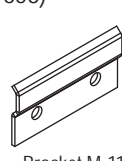
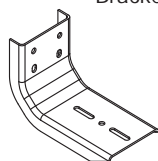
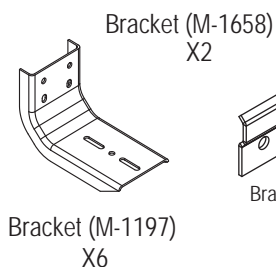
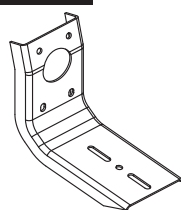

5/16 Flat Washer  
Only used as installation tool



Flange Nut (5/16"-18)  
x 16



Black Flange Bolt  
(5/16" -18 x 1 1/2")  
x 32

### Tools Required



Safety Glasses



Hammer

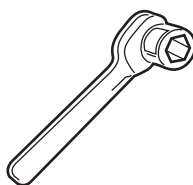

Ratchet with 1/2" Socket

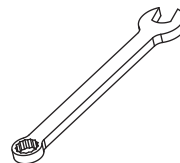

1/2" Wrench

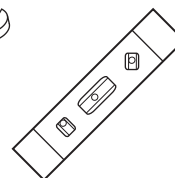

Level

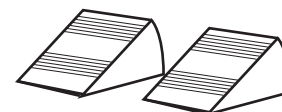

Wheel Chocks

### Preparation Before Installation

1. Park your vehicle in a clean, level location. Check to make sure the vehicle is in park, or for manual drive models, place the transmission in first gear. Engage the parking brake.
2. Chock one wheel on both sides with wheel chocks.
3. Unpack the bracket kit and identify the parts according to the content descriptions above.

## Installation Steps

Front   
Driver's Side Shown

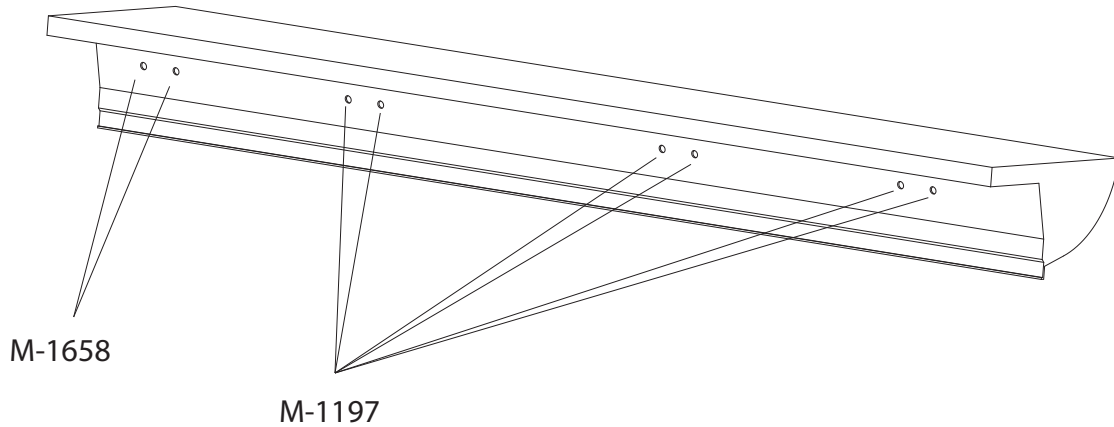

Identify the mounting locations for each bracket by looking under the vehicle and finding the four (4) pairs of holes in the inner rocker panel.

1

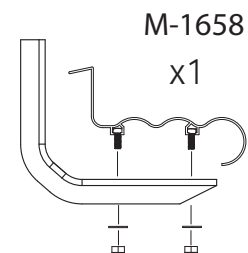
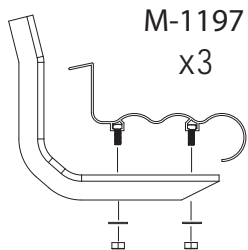

Front   
Driver's Side Shown  
Repeat for Opposite Side

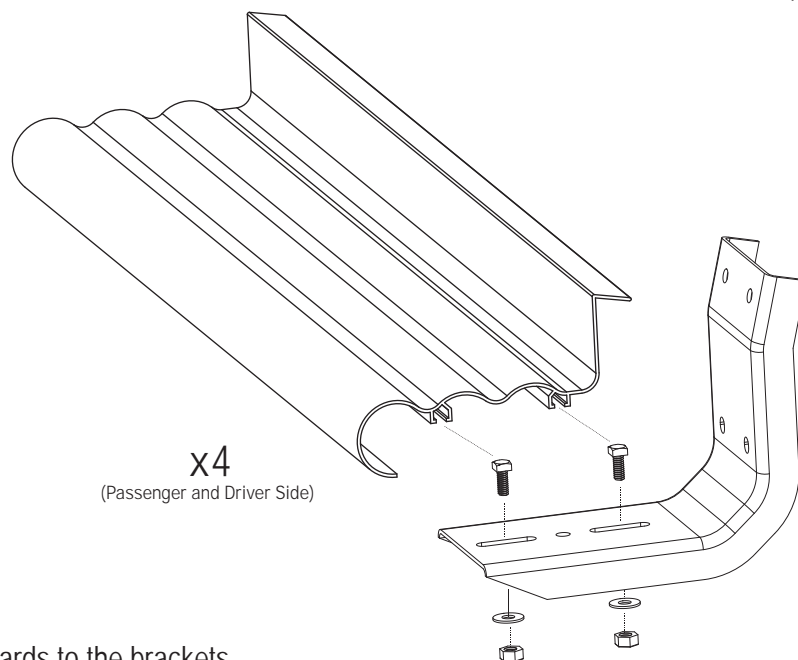

Assemble the running boards to the brackets using square head bolts, washers, and nuts.

2

## Installation Steps

Front   
Driver's Side Shown

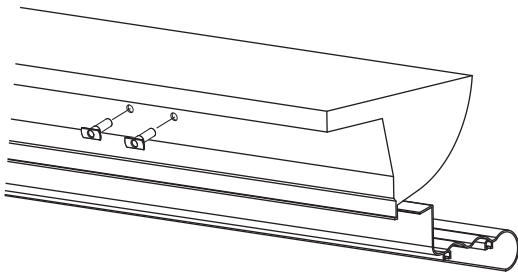

x4  
(Passenger and Driver Side)

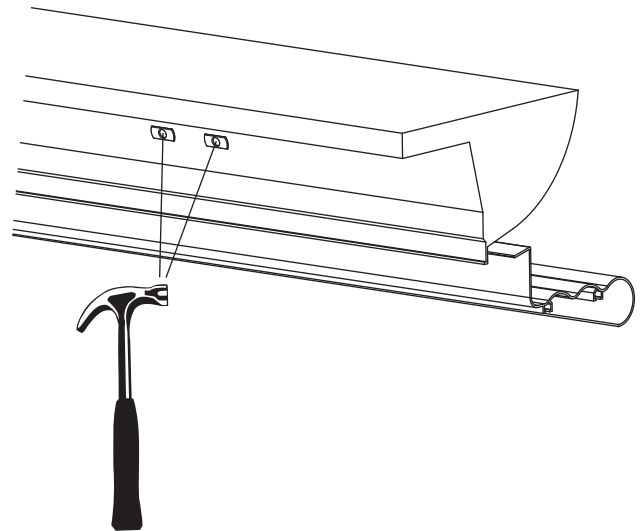

Insert rivnuts into the four (4) pairs of holes in the rocker panel. Use a hammer to tap the rivnuts flush.

3

Front   
Driver's Side Shown

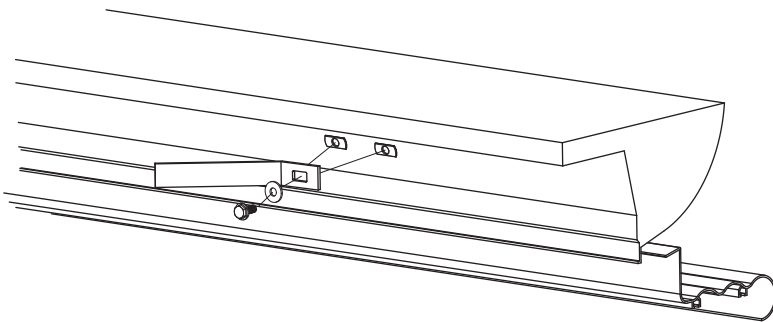

Using the socket, wrench, and washer provided, set each rivnut in the rocker panel. Be sure the washer is on the outside of the wrench to prevent the head of the bolt from going through. Repeat step for all rivnuts.

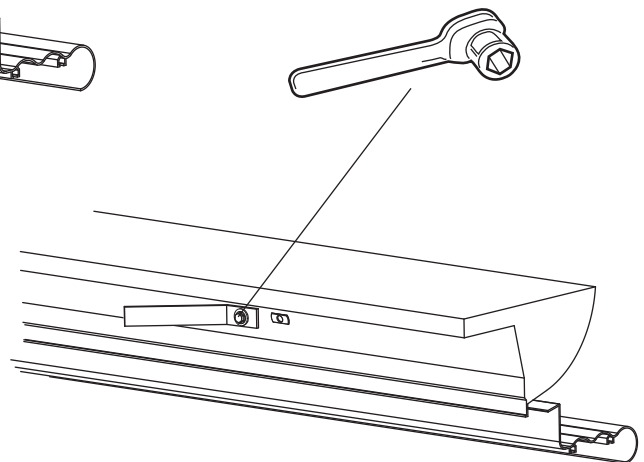

4

## Installation Steps

Front   
Driver's Side Shown

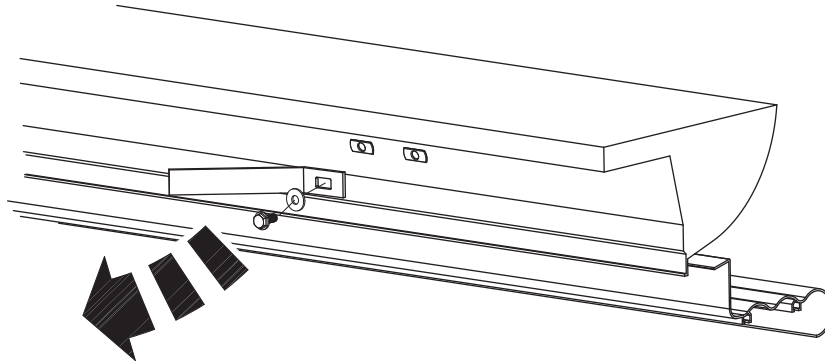

Remove bolt, washer, and wrench from rivnut once fully set in place.

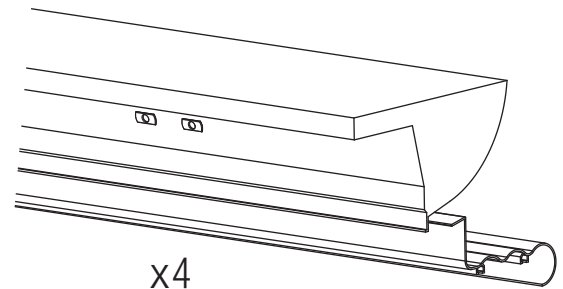

5

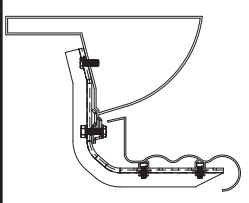

Front   
Driver's Side Shown

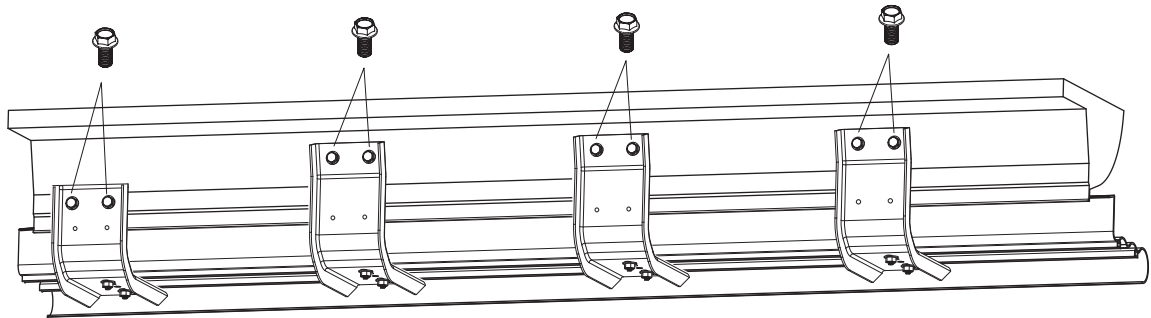

Insert two bolts in the top of each bracket, securing it to the rocker panel. Be sure to keep a loose fit, as you will tighten everything later.

6

## Installation Steps

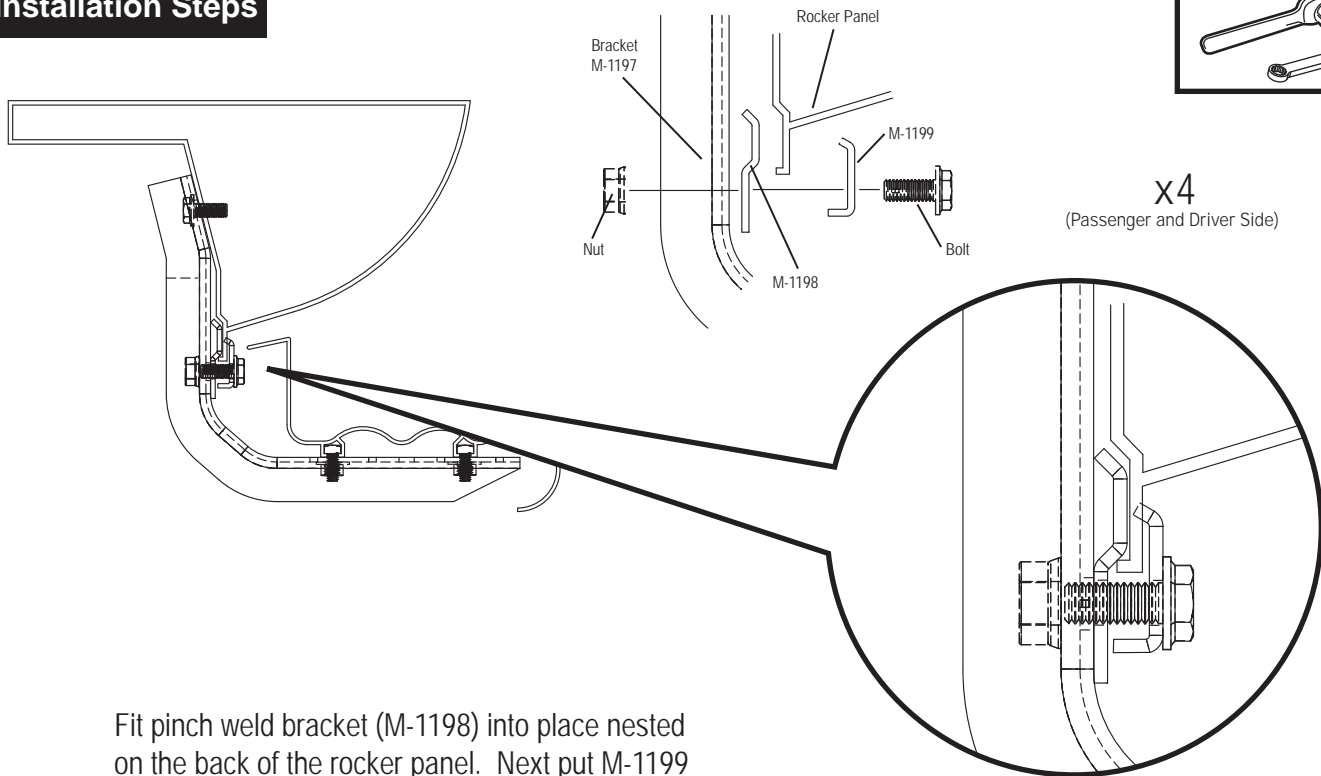

Fit pinch weld bracket (M-1198) into place nested on the back of the rocker panel. Next put M-1199 into place over the top of the pinch weld. Finally slide a bolt through the assembly and finish with a nut.

7

## Inspection After Installation

- Periodically check all components for tightness.

## Care and Cleaning

- Wash with mild soap and dry with a clean cloth.
- Do not use cleaning solvents of any kind.

## Congratulations!

You have purchased one of the many quality Lund® branded products offered by Lund International, Inc. We take the utmost pride in our products and want you to enjoy years of satisfaction from your investment. We have made every effort to ensure that your product is top quality in terms of fit, durability, finish, and ease of installation.

# LUND®

Lund International

800-241-7219 • Visit us at [lundinternational.com](http://lundinternational.com)

© 2012 Lund International, Inc. All rights reserved.

Lund® and the Lund® logo are trademarks of Lund International, Inc.



## Instrucciones De Instalación

# LUND®

## OE Style No Drill Bracket

Para la instalación apropiada y el mejor ajuste posible, lea por favor todas las instrucciones ANTES DE QUE usted comience.

**Para la asistencia técnica u obtener piezas que falta, llame por favor las relaciones de cliente en 1-800-241-7219.**

### Información Importante De Seguridad



#### ADVERTENCIA

- Ser utilizado con Lund® calificado productos solamente.
- No esté parada en el tablero corriente de Lund o no acorchete mientras que el vehículo está en el movimiento.
- No exceda el peso 350lbs. en el sistema del soporte de Lund.
- No utilice los soportes como punto que alza con el gato para el vehículo.
- No utilice al sistema del soporte o a tableros corrientes para sujetar el cargo.
- Compruebe periódicamente todos los componentes para saber si hay tirantéz.



#### PRECAUCIÓN

- Sea seguro usar las gafas de seguridad mientras que instala los soportes.
- Al usar las herramientas eléctricas, lea y entienda todas las instrucciones de funcionamiento.

### Contenido

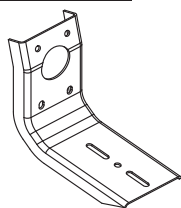

Bracket (M-1197)  
X6

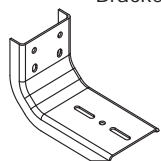

Bracket (M-1658)  
X2

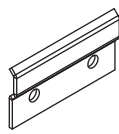

Bracket M-1198  
x 8

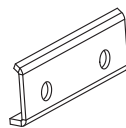

Bracket M-1199  
x 8

Supplied Wrench  
x 1



5/16 Flat Washer  
Only used as installation tool



5/16-18 Riv-Nut  
x 16



Flange Nut (5/16-18)  
x 16



Black Flange Bolt  
(5/16" -18 x 1 1/2")  
x 32

### Herramientas Requeridas



Gafas de seguridad



Martillo

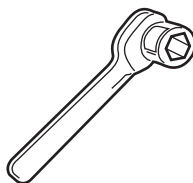

Rachet con el zócalo 1/2"

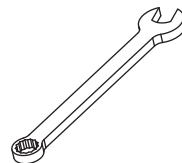

llave del 1/2"

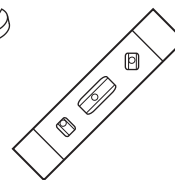

Nivel

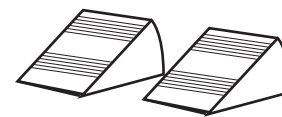

Cuñas De la Rueda

### Preparación Antes De la Instalación

1. Parquee su vehículo en una localización limpia, llana. Compruebe para cerciorarse de que el vehículo esté en parque, o para la impulsión manual modela, pone la transmisión en el primer engranaje. Contrate el freno de estacionamiento.
2. Acuña una rueda en ambos lados con las cuñas de la rueda.
3. Desempaquete el kit del soporte e identifique las piezas según las descripciones contentas arriba.

## Pasos De la Instalación

Frente   
Lado Del Conductor  
Demostrado

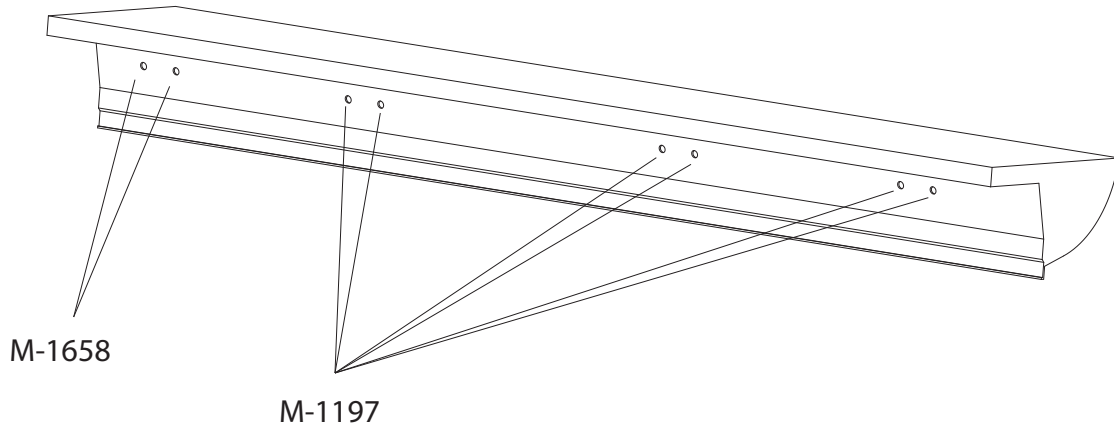

Identifique las localizaciones del montaje para cada soporte mirando debajo del vehículo y encontrando los cuatro (4) pares de agujeros en el panel interno del eje de balancín.

1

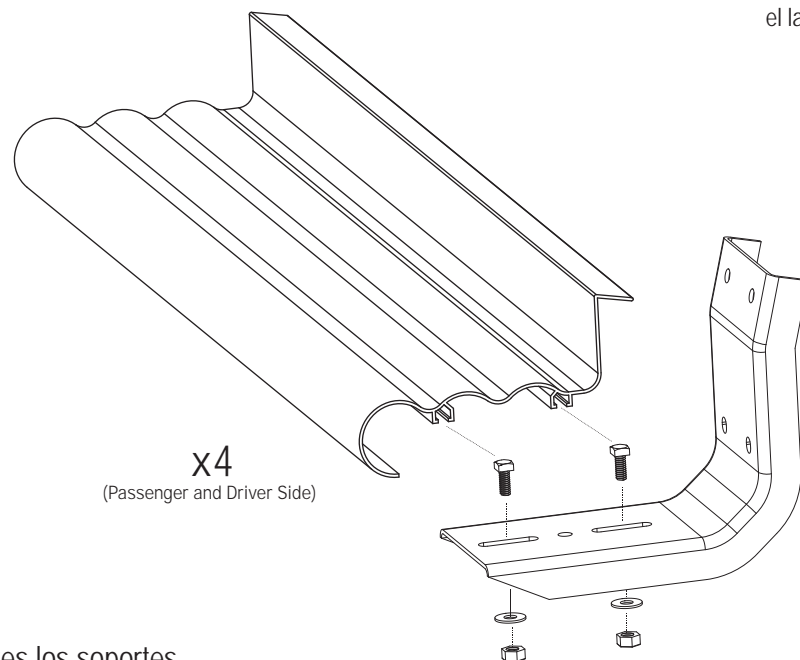
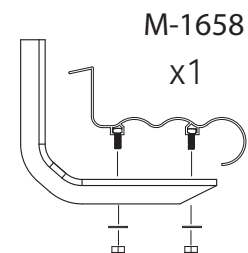
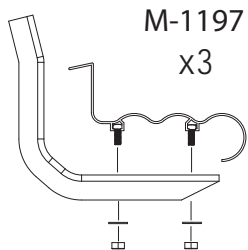

Frente   
Repetición demostrada  
lado del conductor para  
el lado opuesto

Monte a tableros corrientes los soportes usando los pernos, las arandelas, y las tuercas principales cuadrados.

2



## Pasos De la Instalación

Frente →  
Lado Del Conductor  
Demostrado

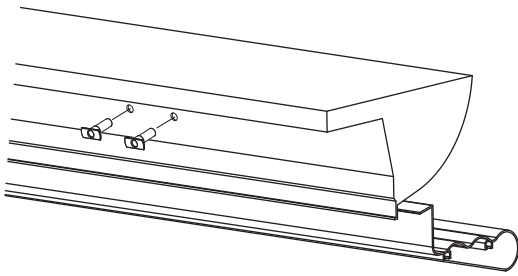

x4  
(Passenger and Driver Side)

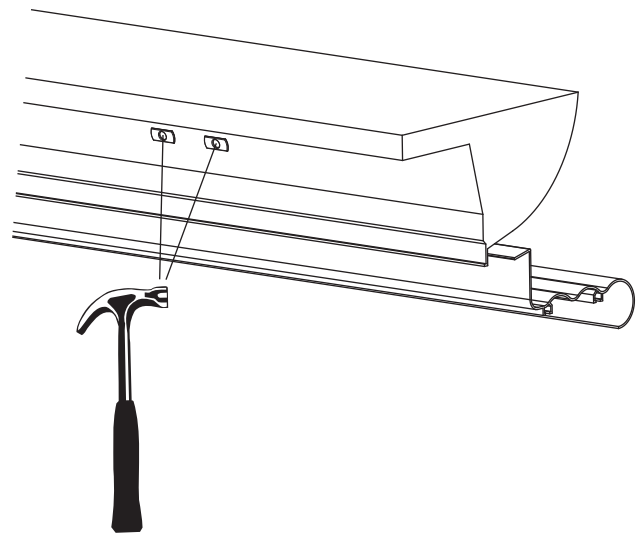

Insert rivnuts into the four (4) pairs of holes in the rocker panel. Use a hammer to tap the rivnuts flush.

3

Frente →  
Lado Del Conductor  
Demostrado

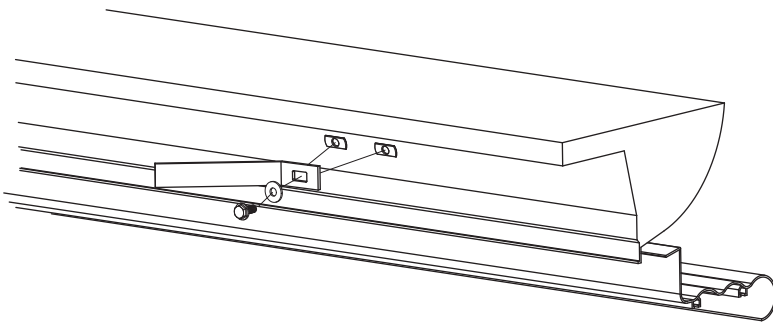

Usando el zócalo, la llave, y la arandela proporcionada, fijaron cada rivnut en el panel del eje de balancín. Sea seguro la arandela está en el exterior de la llave para evitar que vaya el jefe del perno a través. Repita el paso para todos los rivnuts.

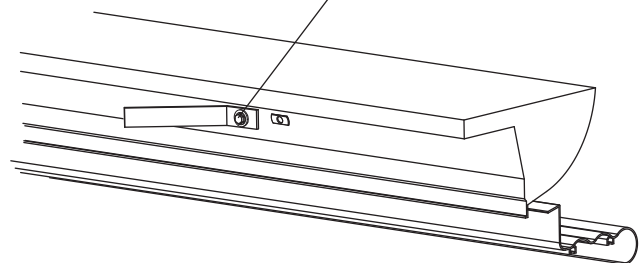

4

## Pasos De la Instalación

Frente →  
Lado Del Conductor  
Demostrado

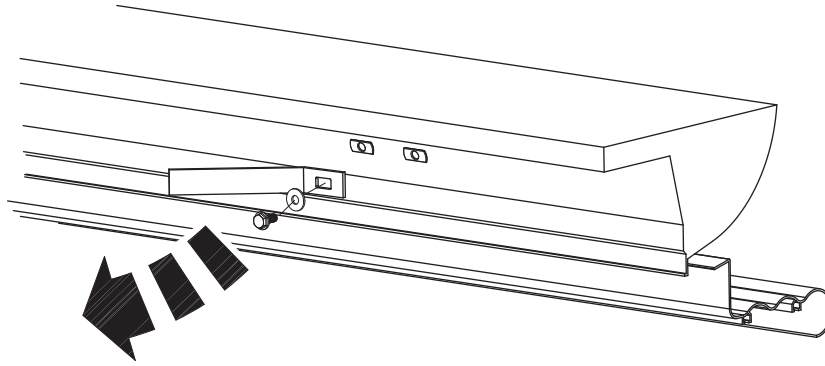

Quite el perno, la arandela, y la llave del rivnut fijado una vez completamente en lugar.

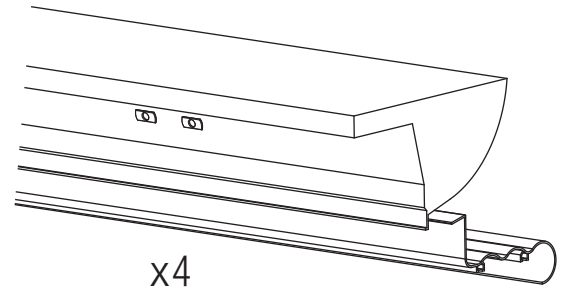

x4  
(Passenger and Driver Side)

5

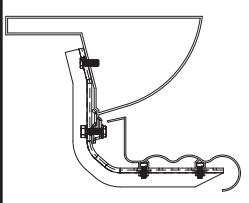

Frente →  
Lado Del Conductor  
Demostrado

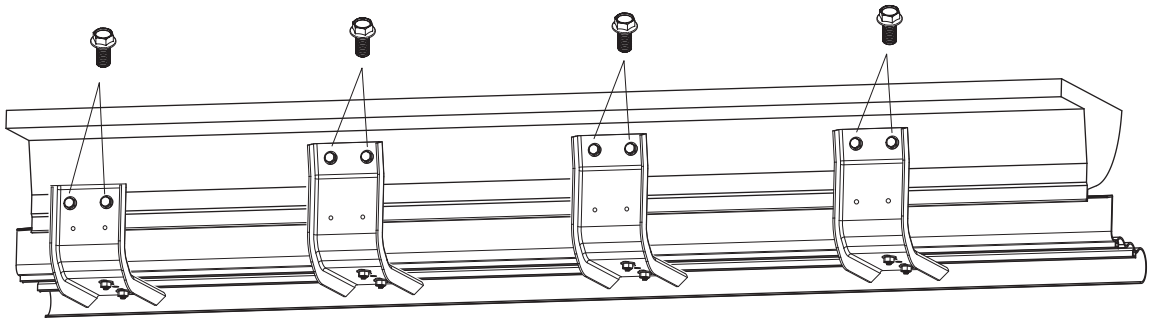

Inserte dos pernos en la tapa de cada soporte, asegurándolo al panel del eje de balancín. Sea seguro guardar un ajuste flojo, pues usted apretará todo más adelante.

6

## Pasos De la Instalación

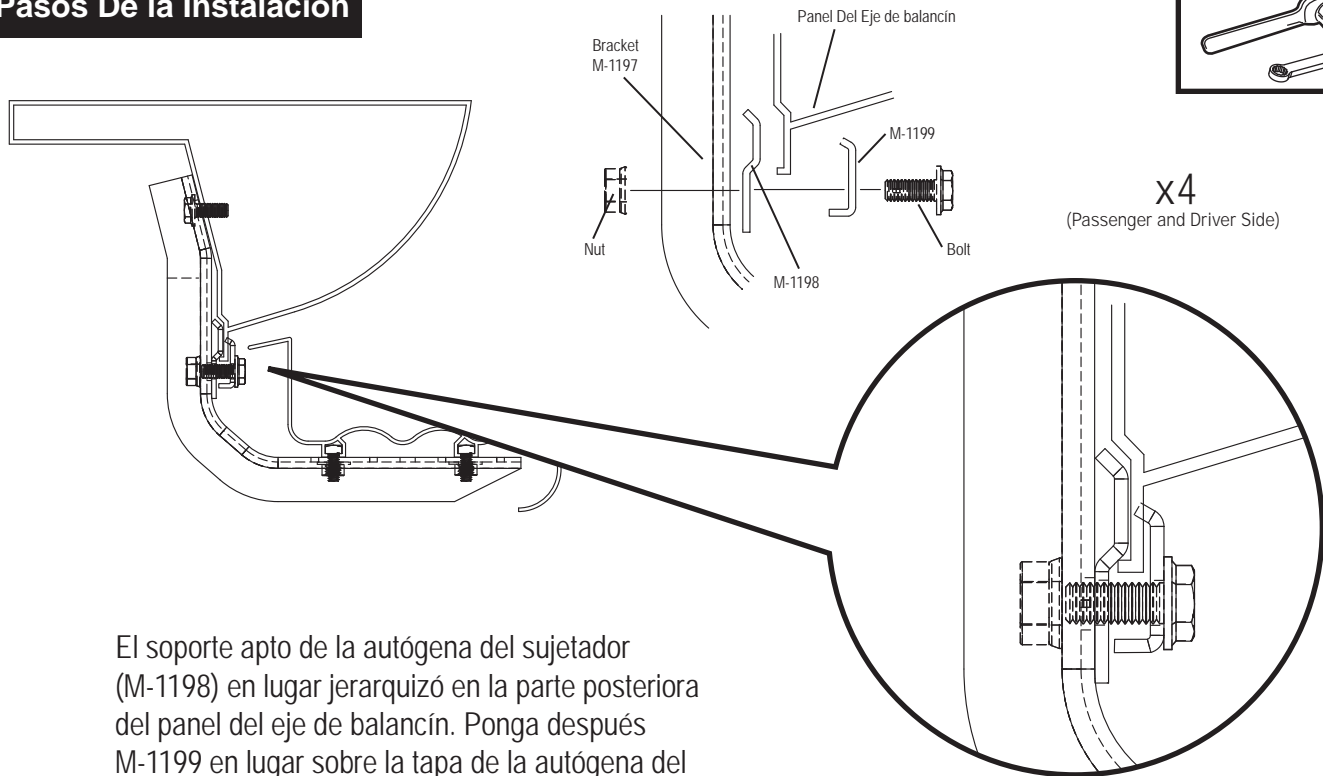

El soporte apto de la autógena del sujetador (M-1198) en lugar jerarquizó en la parte posterior del panel del eje de balancín. Ponga después M-1199 en lugar sobre la tapa de la autógena del sujetador. Finalmente resbale un perno con la asamblea y el final con una tuerca.

7

## Inspección Después De la Instalación

- Compruebe periódicamente todos los componentes para saber si hay tirantez.

## Cuidado y limpieza

- Lávese con el jabón suave y séquese con un paño limpio.
- No utilice los disolventes limpiadores de la clase.

## ¡Felicitaciones!

Usted ha comprado uno de los muchos calidad Lund<sup>®</sup> calificada los productos ofrecidos por Lund internacional, inc.. Tomamos el orgullo extremo en nuestros productos y quisiéramos que usted gozara de años de la satisfacción de su inversión. Hemos hecho cada esfuerzo de asegurarse de que su producto es calidad superior en términos del ajuste, de la durabilidad, del final, y de la facilidad de la instalación.

# LUND<sup>®</sup>

Lund International

800-241-7219 • Visite nuestro sitio Web: [lundinternational.com](http://lundinternational.com)

© 2012 Lund International, Inc. Todos los derechos reservados.

Lund<sup>®</sup> y el logo de Lund<sup>®</sup> son marcas registradas de Lund International, Inc.



## Instructions D'Installation

# LUND®

## OE Style No Drill Bracket

Pour l'installation appropriée et le meilleur ajustement, lisez svp toutes les instructions AVANT QUE vous commenciez.

**Pour l'assistance technique ou pour obtenir les pièces absentes, appelez svp les relations de client à 1-800-241-7219.**

### L'Information Importante De Sûreté



#### AVERTISSEMENT

- Être employé avec Lund a stigmatisé des produits seulement.
- Ne vous tenez pas sur le conseil courant de Lund ou n'encadrez pas tandis que le véhicule est dans le mouvement.
- N'exécédez pas le poids 350lbs. sur le système de parenthèse de Lund.
- N'utilisez pas les parenthèses comme appui de levage pour le véhicule.
- N'employez pas le système de parenthèse ou les conseils courants pour attacher la cargaison.
- Examinez périodiquement tous les composants pour assurer l'étanchéité.



#### ATTENTION

- Soyez sûr de porter des verres de sûreté tout en installant des parenthèses.
- À l'aide des machines-outils, lisez et comprenez toutes les consignes d'utilisation.

### Table des matières

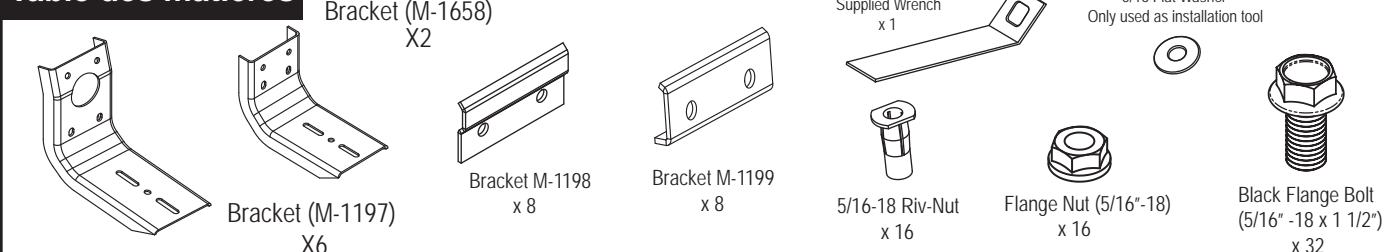

### Outils Requis

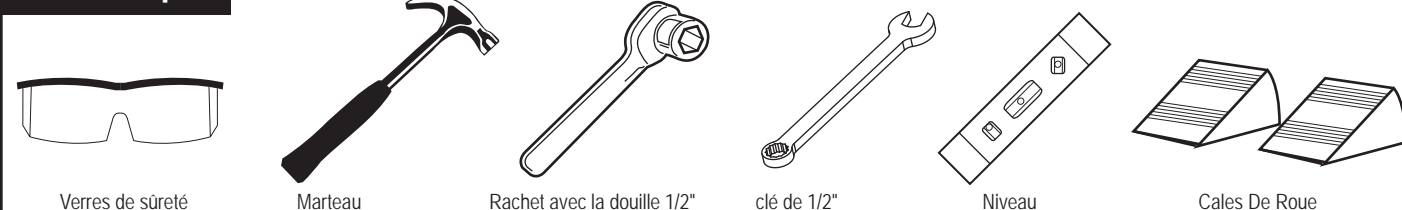

### Préparation Avant Installation

1. Garez votre véhicule dans un endroit propre et de niveau. Vérifiez pour s'assurer que le véhicule est en parc, ou pour la commande manuelle modèle, place la transmission dans la première vitesse. Engagez le frein de stationnement.
2. Calez une roue des deux côtés avec des cales de roue.
3. Déballez le kit de parenthèse et identifiez les pièces selon les descriptions contenues ci-dessus.

## Étapes D'Installation

Avant   
Le Côté Du  
Conducteur Montré

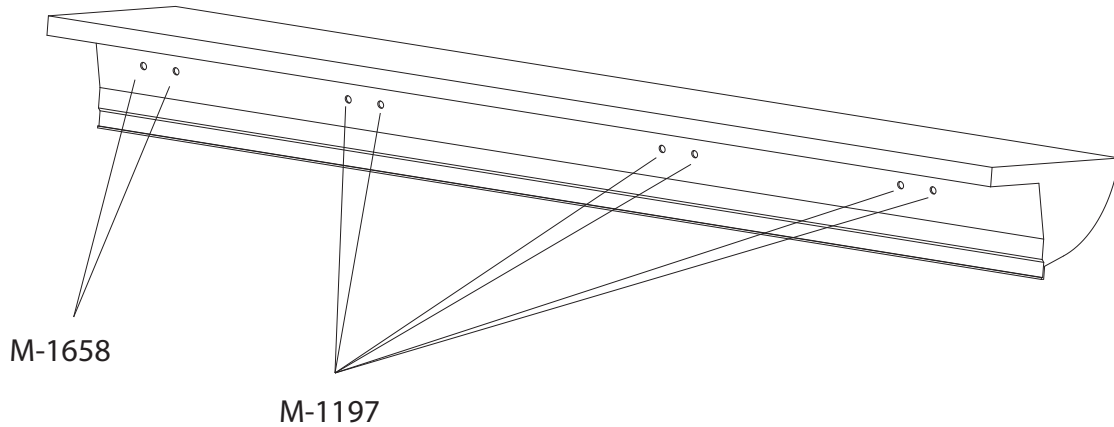

Identifiez les endroits de support pour chaque parenthèse en regardant sous le véhicule et en trouvant les quatre (4) paires de trous dans le panneau intérieur de culbuteur.

1

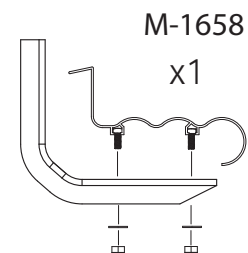
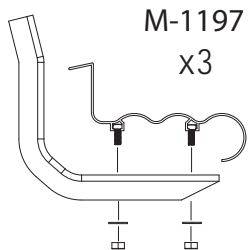

Avant   
La répétition montrée  
par côté du conducteur  
pour le côté opposé

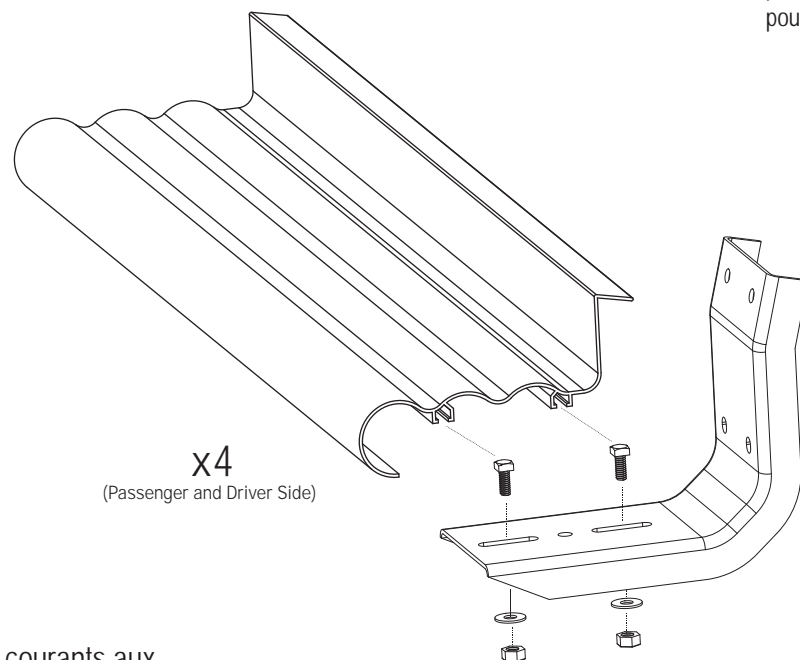

Rassemblez les conseils courants aux parenthèses à l'aide des boulons, des rondelles, et des écrous principaux carrés.

2

## Étapes D'Installation

Avant   
Le Côté Du  
Conducteur Montré

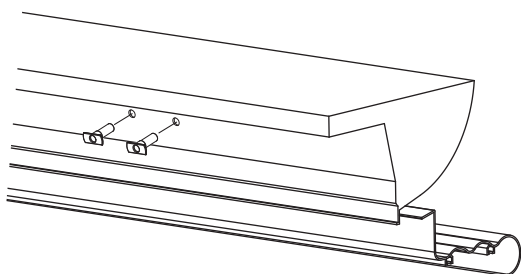

x4  
(Passenger and Driver Side)

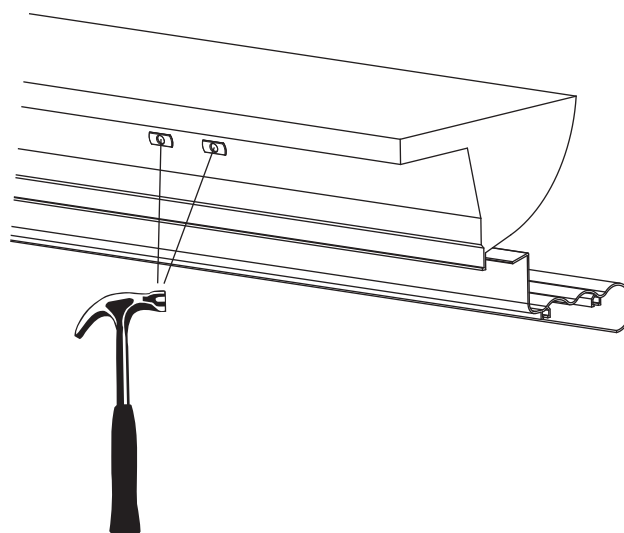

Insérez les rivnuts dans les quatre (4) paires de trous dans le panneau de culbuteur. Utilisez un marteau pour taper les rivnuts à affleurement.

3

Avant   
Le Côté Du  
Conducteur Montré

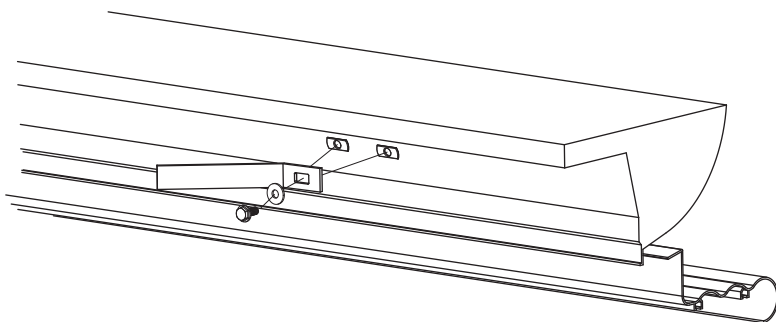

Utilisant la douille, la clé, et la rondelle fournie, on place chaque rivnut dans le panneau de culbuteur. Soyez sûr que la rondelle est sur l'extérieur de la clé pour empêcher la tête du boulon d'intervenir. Répétez l'étape pour tous les rivnuts.

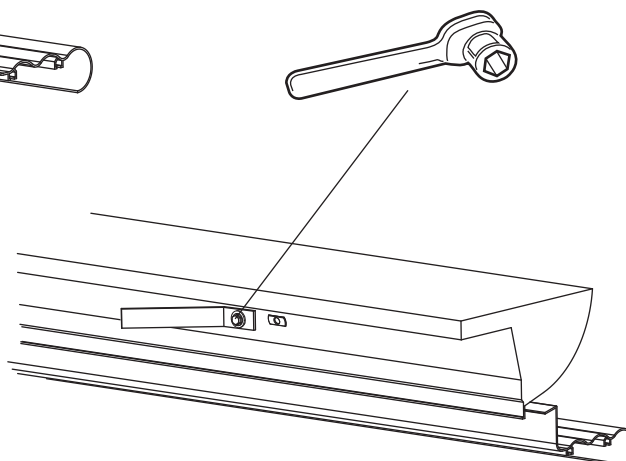

4

## Étapes D'Installation

Avant   
Le Côté Du  
Conducteur Montré

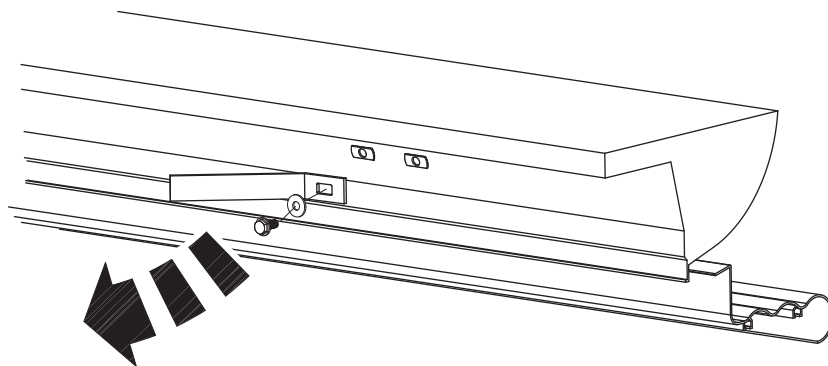

Enlevez le boulon, la rondelle, et la clé du rivnut  
une fois entièrement réglé en place.

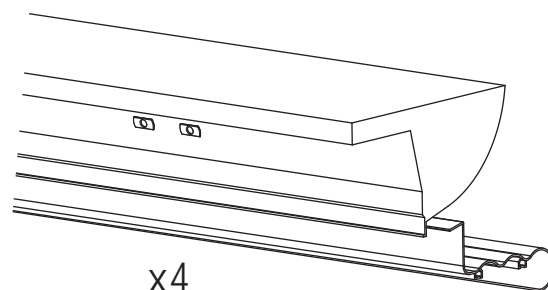

x4  
(Passenger and Driver Side)

5

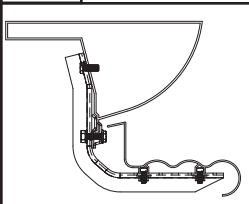

Avant   
Le Côté Du  
Conducteur Montré

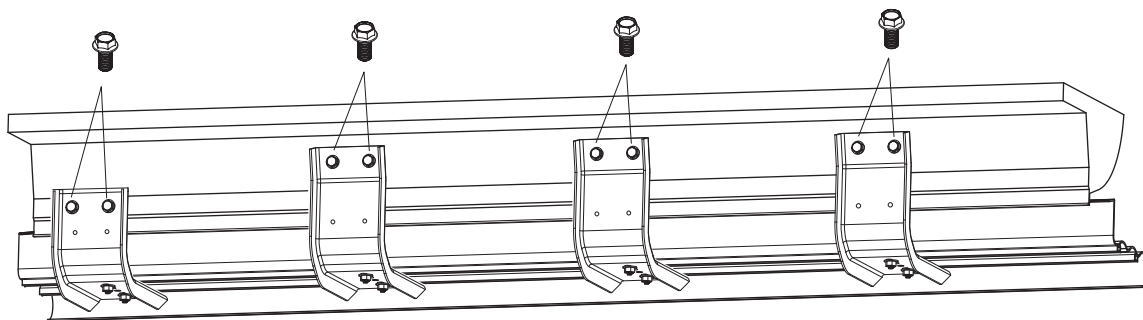

Insérez deux boulons dans le dessus de  
chaque parenthèse, le fixant au panneau de  
culbuteur. Soyez sûr de garder un ajustement  
lâche, car vous serrerez tout plus tard.

6



## Étapes D'Installation

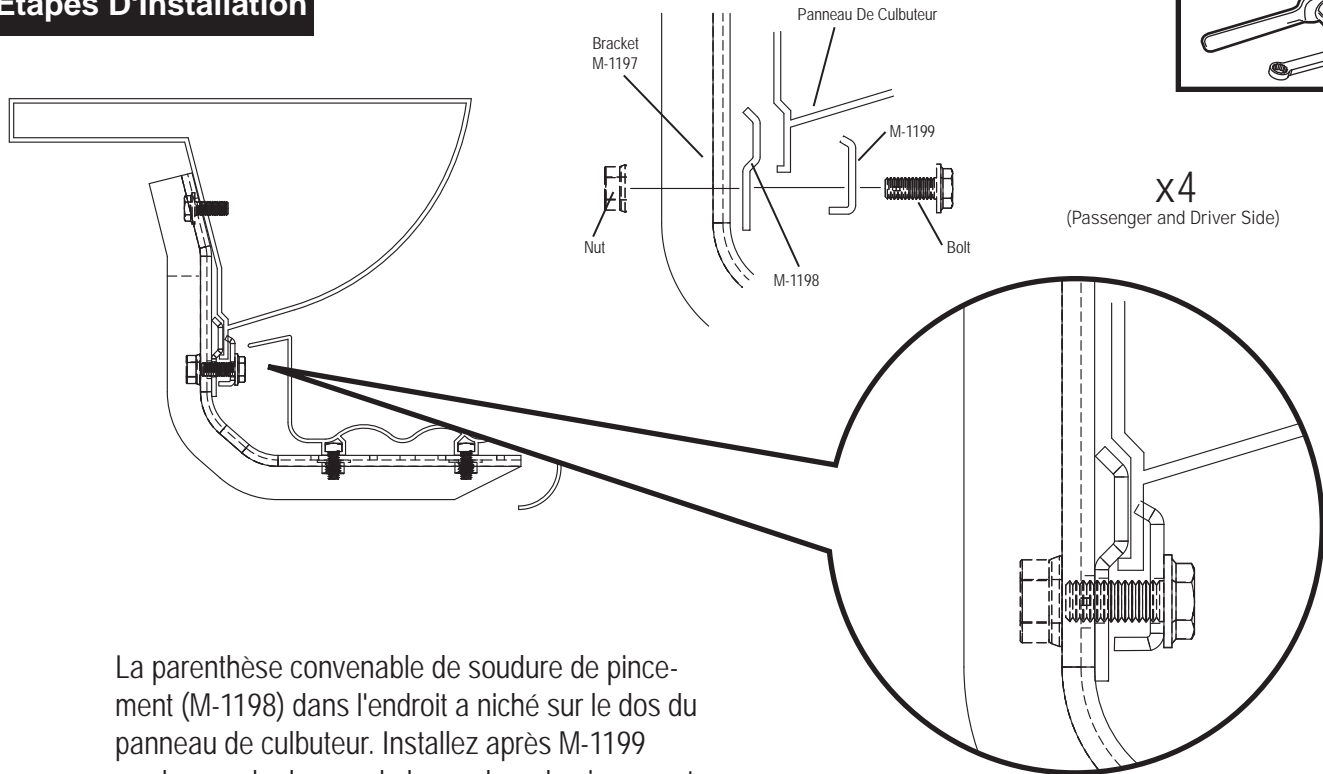

La parenthèse convenable de soudure de pincement (M-1198) dans l'endroit a niché sur le dos du panneau de culbuteur. Installez après M-1199 au-dessus du dessus de la soudure de pincement. Glissez enfin un boulon par l'assemblée et la finition avec un écrou.

7

## Inspection Après Installation

- Examinez périodiquement tous les composants pour assurer l'étanchéité.

## Soin et nettoyage

- Lavez avec du savon doux et séchez avec un tissu propre.
- N'employez pas les dissolvants de nettoyage de la sorte.

## Félicitations !

Vous avez acheté un des nombreux qualité Lund<sup>®</sup> marqué des produits offerts par Lund international, inc.. Nous prenons la plus grande fierté dans nos produits et voulons que vous appréciez des années de satisfaction de votre investissement. Nous avons fait tout effort de s'assurer que votre produit est qualité supérieure en termes d'ajustement, longévité, finition, et facilité d'installation.

# LUND<sup>®</sup>

Lund International

800-241-7219 • Visitez notre site [lundinternational.com](http://lundinternational.com)

© 2012 Lund International, Inc. Tous droits réservés.

Lund<sup>®</sup> et le logo Lund<sup>®</sup> sont des marques déposées de Lund International, Inc.



TM

