

Installation Instructions

I - Sheet Number I-1185 Rev.A



**For proper installation and best possible fit, please read all instructions BEFORE you begin.
For technical assistance or to obtain missing parts, please call Customer Relations at 1-800-328-5863.**

Important Safety Information



- CAUTION - Before driving, ensure that the hood shield is properly secured to vehicle.
- Do not use automatic "brush-style" car washes.
- Do not use cleaning solvents of any kind.
- Periodically check all components for tightness.

Contents

NOTE: Actual product may vary from illustration.



Hood shield

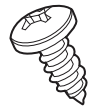

Screw x2
(39-4126)

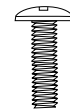

Machine Screw x2
(04-4128)



Bracket x2
(39-1977)



Protective Film x2
(45-3601)



Large Black Plastic Washer x2
(37-4109)



Small Black Plastic Washer x2
(37-4106)

Tools Required



Car Wash Supplies

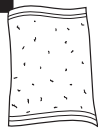

Clean Towel

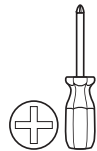

Phillips
screwdriver



Pen

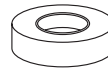

Drill stop
collar

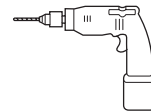

Drill with 1/8"
(3mm) bit



Safety Glasses

Preparation Before Painting / Installation

- A trial fit is recommended to ensure proper positioning and fit.
- Check fit of parts before painting as we will not accept the return of modified or painted parts.
- Wash and dry your vehicle to remove any debris and/or dirt from the installation area.

Installation Steps

NOTE: Actual application may vary slightly from illustrations.

Open hood.

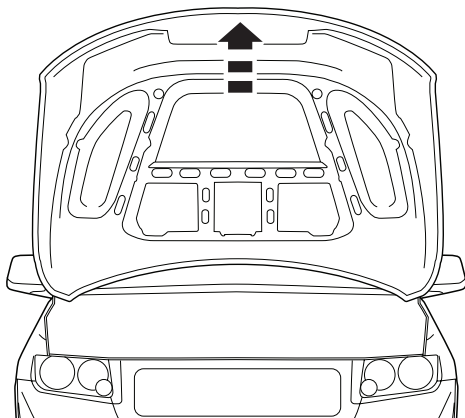

1

Align hood shield with hood edge, and note the four (4) points that the hood shield flange will contact hood.

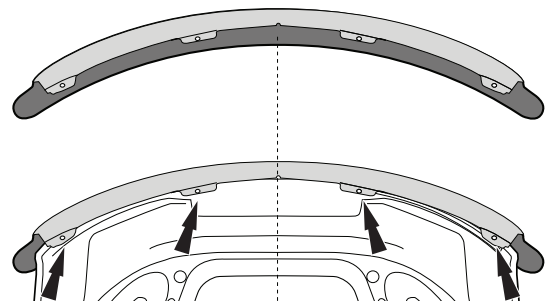

2

Installation Steps

NOTE: Actual application may vary slightly from illustrations.

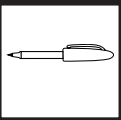

Mark all four (4) hole locations with a pen.

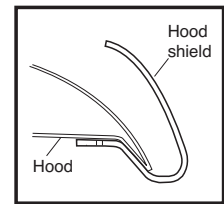
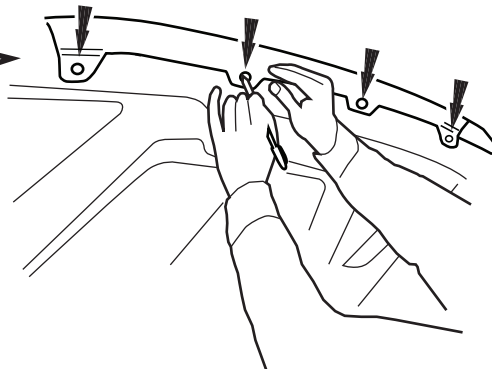
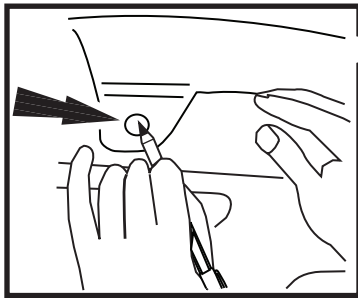

3

Remove the hood shield from hood.

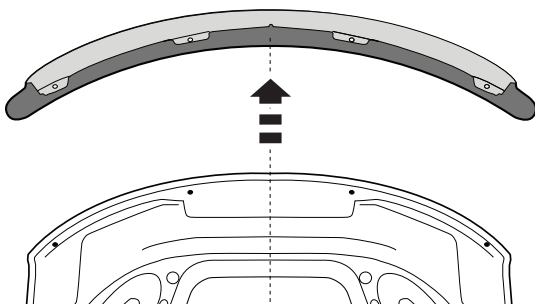

4

Center protective film over the two (2) **OUTBOARD** marks made in **Step 3**, and wrap around the hood edge.

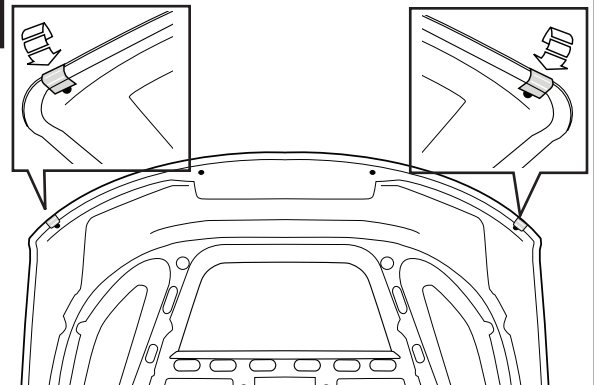
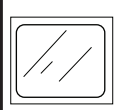

5



Using a 1/8" (3mm) drill bit and a drill stop collar, drill **ONLY two (2)** pilot holes in the underside of the hood at the **two (2) INBOARD** locations marked in **Step 3**.

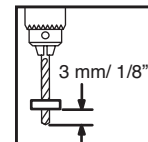
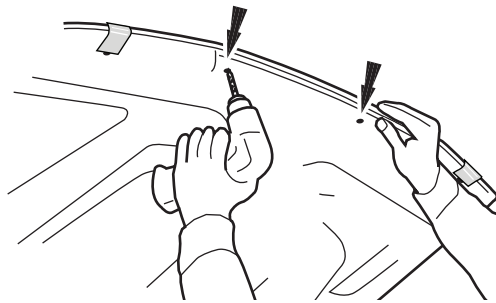

6



NOTE: Exercise extreme caution and do **NOT** drill through hood surface.

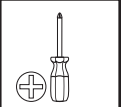

Install brackets on both **OUTBOARD** hood shield flanges using machine screw and small black washer.

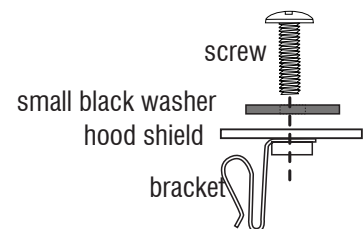
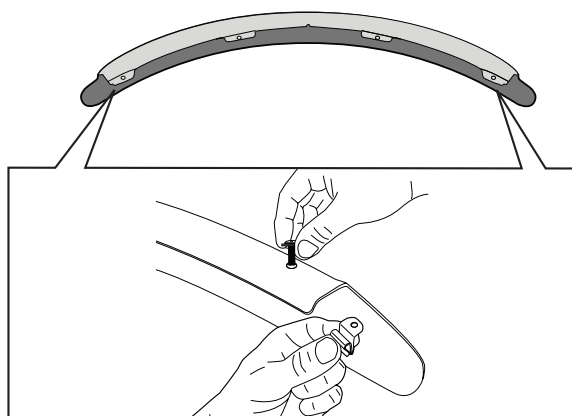
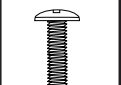

7

Installation Steps

NOTE: Actual application may vary slightly from illustrations.



Position hood shield back on hood edge. Align holes. Slide bracket over hood edge, ensuring that it is centered on the protective film previously installed in **Step 5**.

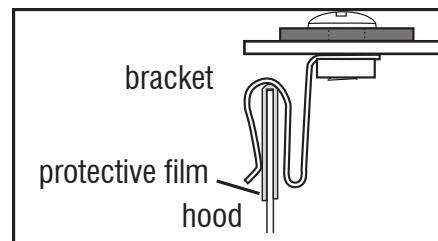
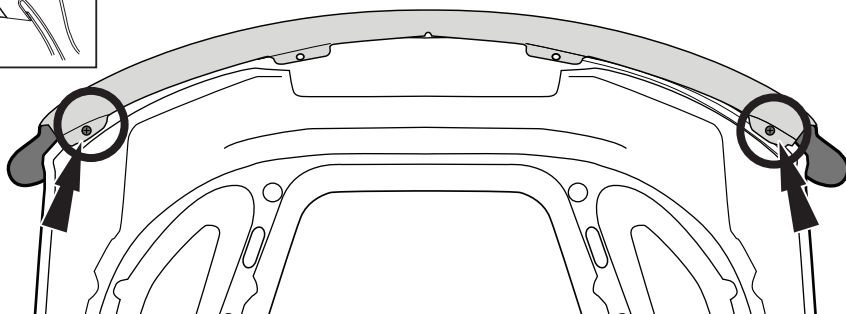

8



Install screw with large black washer through **INBOARD** holes. Tighten into pilot holes drilled previously in **Step 6**.

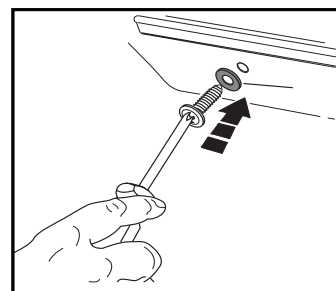
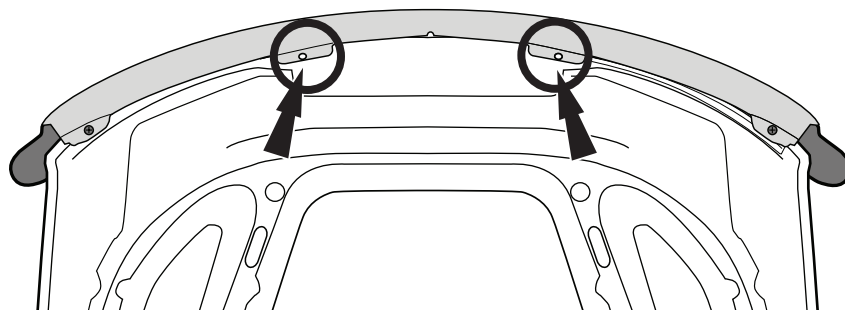

9



DO NOT OVER TIGHTEN

Carefully close hood.

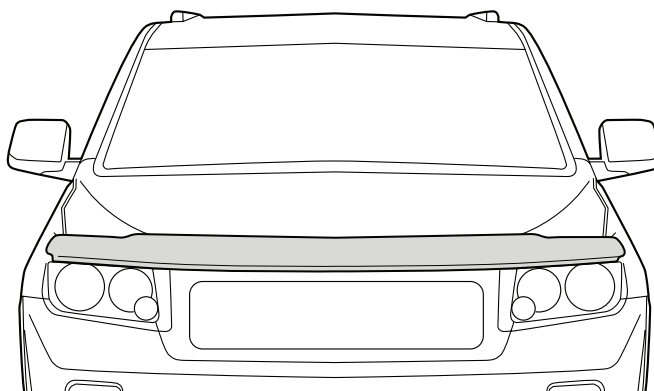

10

Care and Cleaning

- Wash only with mild soap & dry with a clean cloth.

Congratulations!

You have purchased one of the many quality Lund[®] branded products offered by Lund International, Inc. We take the utmost pride in our products and want you to enjoy years of satisfaction from your investment. We have made every effort to ensure that your product is top quality in terms of fit, durability, finish and ease of installation.



Lund International, Lund Accessories Division
4325 Hamilton Mill Rd. Suite 400, Buford, GA 30518
800-328-5863 • Visit us at lundinternational.com

© 2011 Lund International, Inc. All rights reserved.
Lund[®] and the Lund[®] logo are trademarks of Lund International, Inc.





Interceptor™

Veillez lire l'ensemble des instructions AVANT d'utiliser le produit afin de garantir une installation correcte et un ajustement optimal. Pour obtenir une assistance technique ou demander des pièces manquantes, veuillez appeler le service clientèle au 1-800-328-5863.

Consignes de sécurité importantes



- **PRÉCAUTION** - Avant de conduire, vérifiez que le bouclier du capot est bien ancré au véhicule.
- N'utilisez pas les postes de lavage à brosses.
- N'utilisez pas de solvants lors du lavage.
- Vérifiez régulièrement que les composants sont bien fixés.

Contenu

REMARQUE : Le produit réel peut différer du modèle illustré.



Protection de capot



2 vis
(39-4126)



2 vis à métaux
(04-4128)



2 supports
(39-1977)



2 films protecteurs
(45-3601)



2 grandes rondelles en plastic noir
(37-4109)



2 petites rondelles en plastic noir
(37-4106)

Outils nécessaires



Équipement
de nettoyage

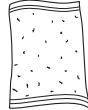

Chiffon
propre

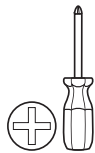

Tournevis
Phillips



Stylo



Collier de butée
de perçage

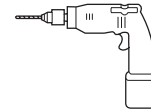

Foreuse avec mèche
de 1/8" (3 mm)



Lunettes
de protection

Préparation avant la peinture/installation

- Effectuez d'abord un essai afin de vous assurer que le produit s'adapte à votre véhicule.
- Vérifiez que les pièces peuvent être correctement mises en place avant de peindre car nous n'acceptons pas le retour de pièces modifiées ou peintes.
- Lavez et séchez votre véhicule pour retirer tout débris et/ou saleté de la zone d'installation.

Étapes d'installation

REMARQUE : La méthode d'application peut être légèrement différente de celle représentée par les illustrations.

Ouvrez le capot.

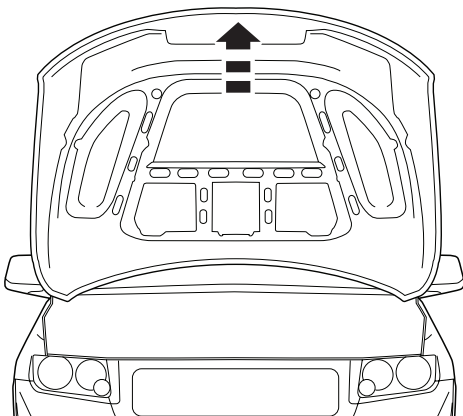

1

Alignez le protecteur de capot avec le rebord du capot, et notez les quatre (4) points de contact de la bride du protecteur de capot avec le capot.

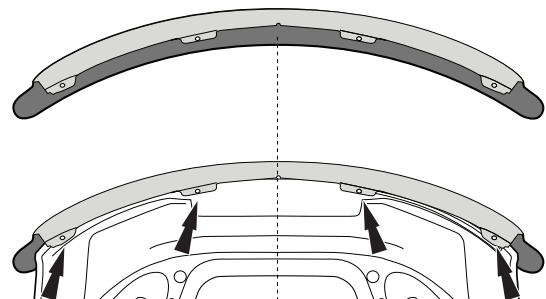

2

Étapes d'installation

REMARQUE : La méthode d'application peut être légèrement différente de celle représentée par les illustrations.



Marquez chacun des quatre (4) emplacements de trous avec un stylo.

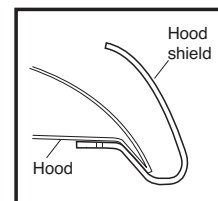
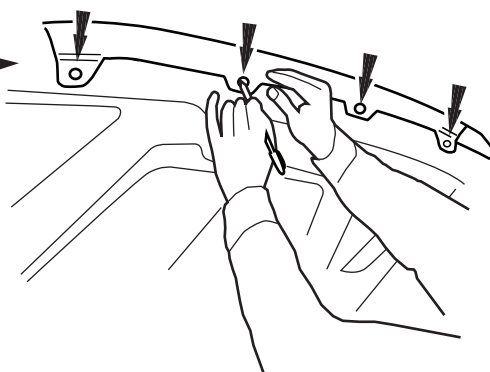
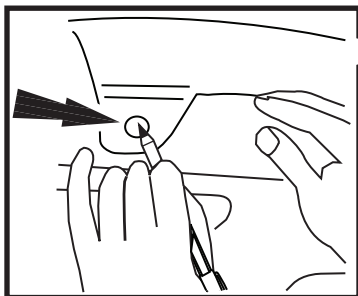

3

Retirez la protection de capot du capot.

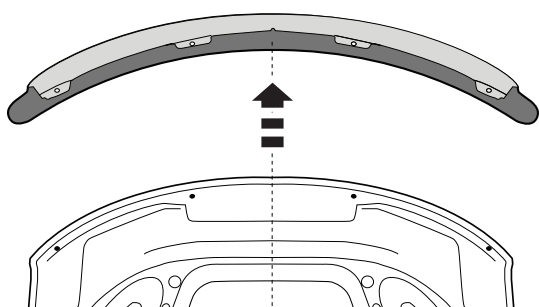

4

Centrez le film protecteur sur les deux (2) marquages **EXTÉRIEURS** réalisés à l'étape 3 et emballez autour du bord du capot.

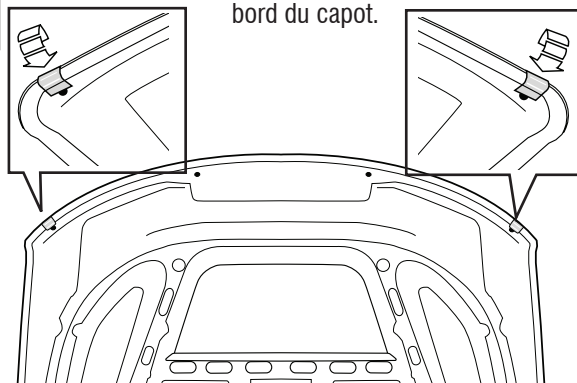

5

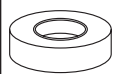
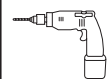

À l'aide d'une foreuse avec mèche de 1/8" (3 mm) et d'un collier de butée de perçage, percez **UNIQUEMENT deux (2) trous pilotes** dans le côté inférieur du capot aux **deux (2) endroits INTÉRIEURS** indiqués à l'étape 3.

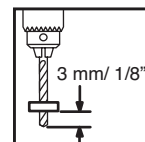
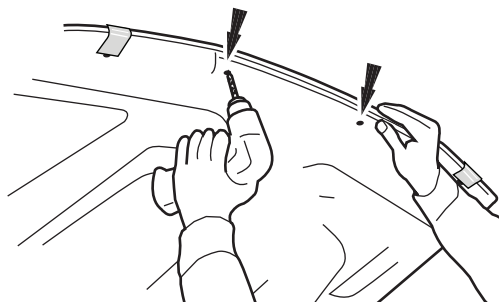

6



REMARQUE : Faites preuve d'une extrême prudence et ne passez **PAS** à travers la surface du capot en perçant.



Installez les supports sur les deux brides de protection de capot **EXTÉRIEURS** à l'aide de vis à métaux et des petites rondelles noires.



7

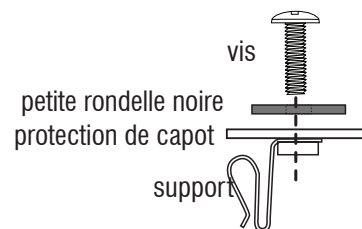
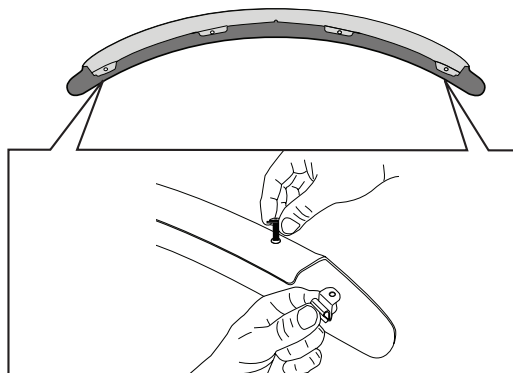

Étapes d'installation

REMARQUE : La méthode d'application peut être légèrement différente de celle représentée par les illustrations.

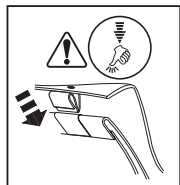

Remplacez le protecteur de capot sur le rebord du capot. Alignez les trous. Faites glisser le support au-dessus du bord du capot, en vous assurant qu'il soit centré sur le film protecteur installé précédemment à l'étape 5.

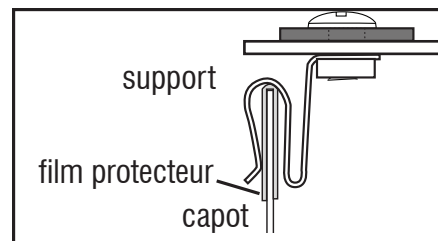
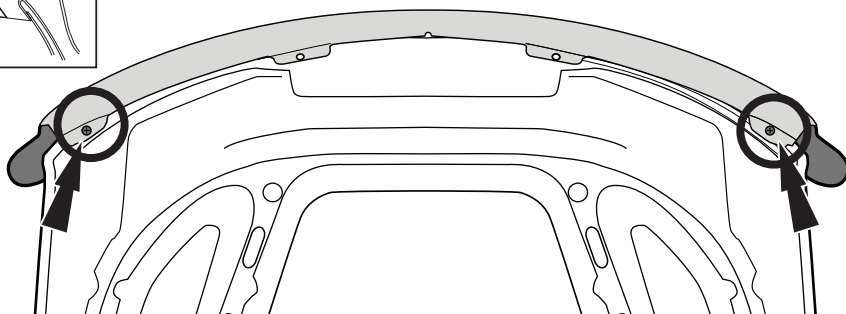

8



Posez la vis avec la grande rondelle noire à travers les trous **INTÉRIEURS**. Serrez dans les trous pilotes percés précédemment à l'étape 6.

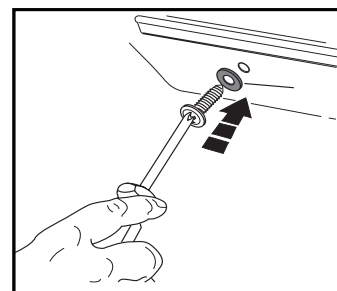
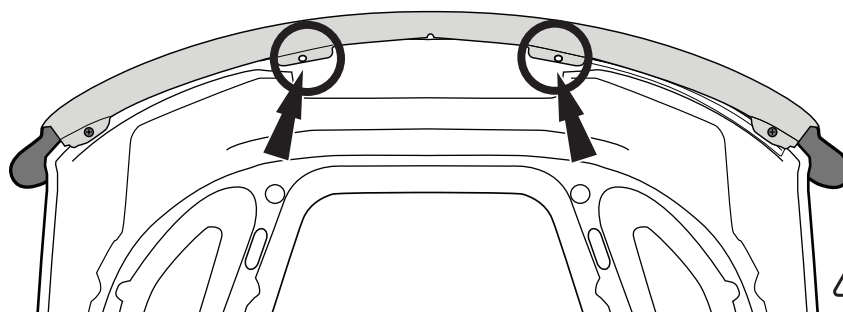

9



NE PAS SERRER À L'EXCÈS

Fermez soigneusement le capot.

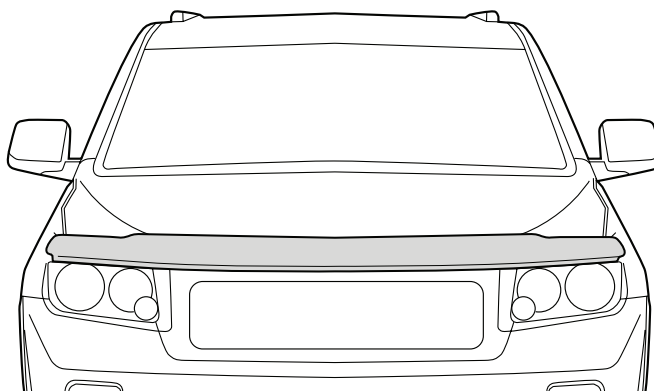

10

Entretien et nettoyage

- Utilisez uniquement un détergent doux pour le nettoyage et séchez à l'aide d'un chiffon propre.

Félicitations !

Vous venez d'acheter un des nombreux produits de qualité de la marque Lund[®] fabriqués par Lund International, Inc. Nous sommes extrêmement fiers de la qualité de nos produits et nous espérons que vous profiterez de cet investissement de longues années durant. Nous nous efforçons d'offrir la meilleure qualité en termes d'ajustement, de finition, de durabilité et de facilité d'installation.



Lund International, Lund Accessories Division
4325 Hamilton Mill Rd. Suite 400, Buford, GA 30518
800-328-5863 • Visitez notre site Web lundinternational.com

© 2011 Lund International, Inc. Tous droits réservés.
Lund[®] et le logo Lund[®] sont des marques déposées de Lund International, Inc.





Interceptor™

Para la instalación correcta y el mejor ajuste posible, lea las instrucciones ANTES de comenzar.
Para pedir asistencia técnica u obtener las partes que faltan, llame a Atención al Cliente al 1-800-328-5863.

Información importante de seguridad

- ⚠ **ADVERTENCIA:** Antes de conducir, asegúrese que la cubierta del capó esté debidamente sujeta al vehículo.
- No use servicios automáticos de limpieza de vehículos que utilizan cepillos.
- No use solventes para limpieza de ningún tipo.
- Compruebe periódicamente que todos los componentes estén ajustados.

Contenido **NOTA:** El producto real tal vez no sea igual a la ilustración.

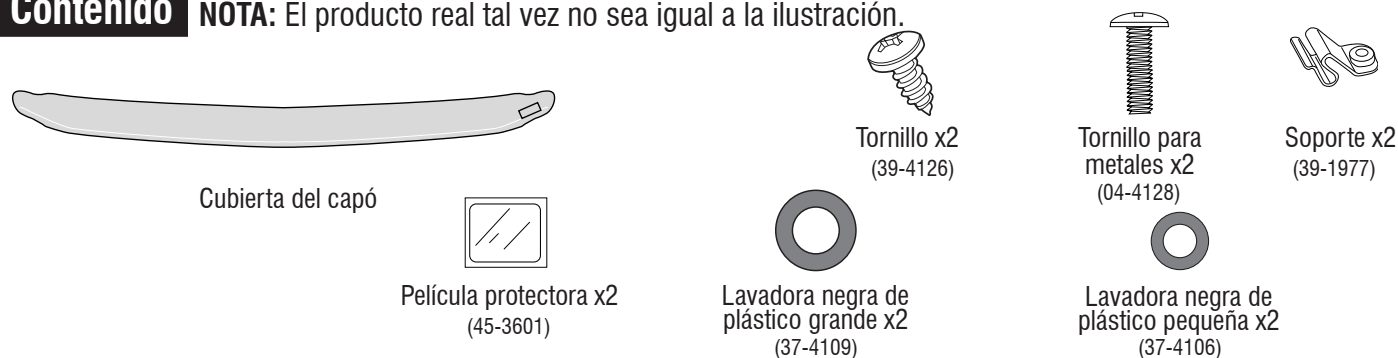

Herramientas necesarias

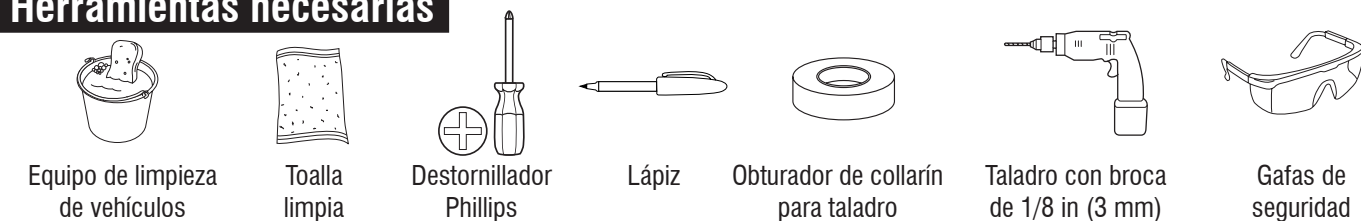

Preparación antes de pintar / instalar

- Se recomienda realizar un ajuste de prueba para garantizar el posicionamiento y ajuste correctos.
- Compruebe que las piezas se ajusten correctamente antes de pintarlas, ya que no aceptaremos la devolución de piezas modificadas o pintadas.
- Lave y seque su vehículo para quitar cualquier desecho o suciedad del área de instalación.

Pasos de instalación **NOTA:** La aplicación real tal vez no sea igual a las ilustraciones.

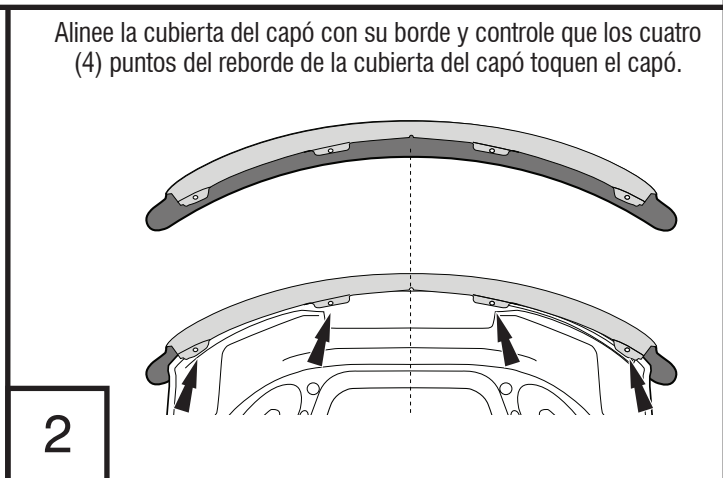
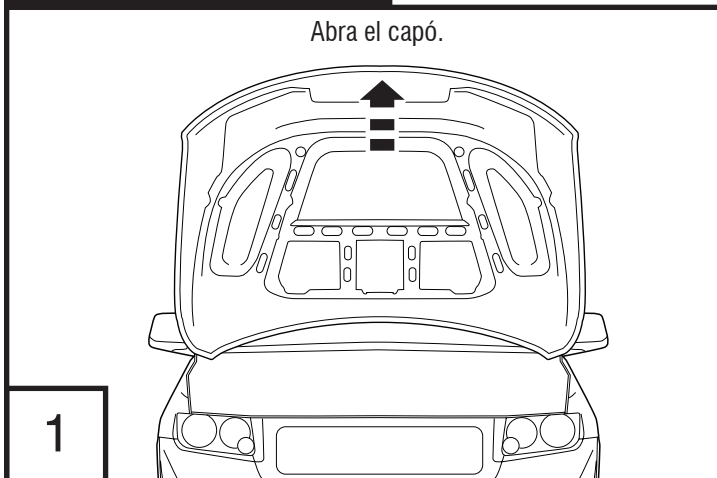

Pasos de instalación **NOTA:** La aplicación real tal vez no sea igual a las ilustraciones.



Marque la ubicación de los cuatro (4) orificios con un lápiz.

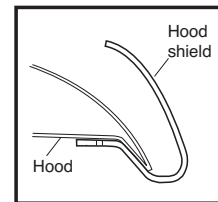
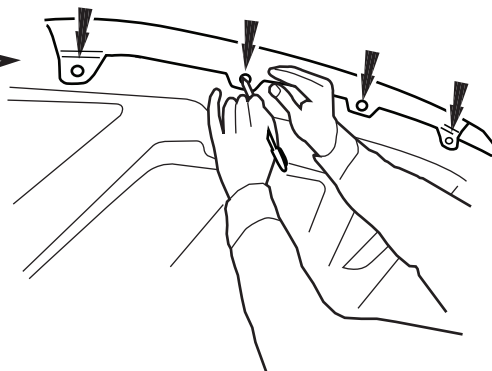
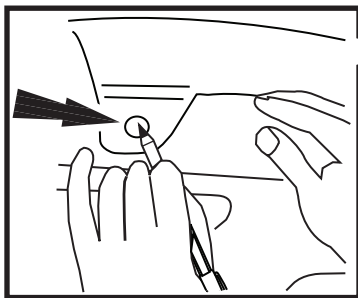

3

Quite la cubierta del capó.

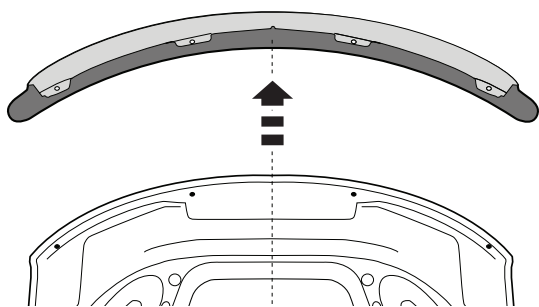

4

Coloque la película protectora sobre las dos (2) marcas **EXTERIORES** realizadas en el **Paso 3** y envuelva con ella el borde del capó.

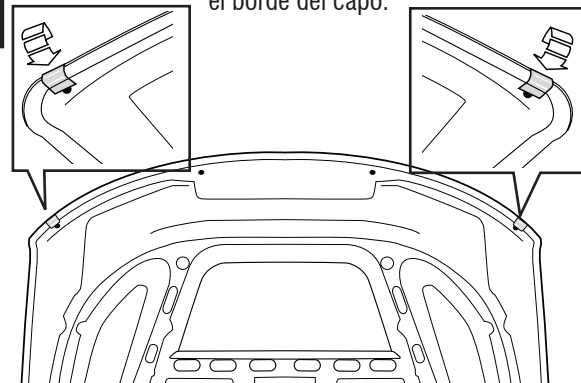

5

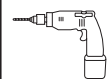

Con una broca de 1/8 in (3 mm) de taladro y un obturador de collarín para taladro, perfore **SÓLO dos (2)** orificios guía en la parte inferior del capó en los **dos (2) puntos en el INTERIOR** marcados en el **Paso 3**.

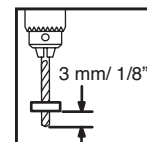
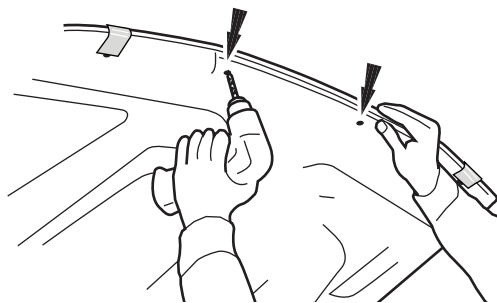
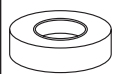

6



NOTA: Preste especial atención y **NO** perfore la superficie del capó.



Instale los soportes en ambos rebordes **EXTERIORES** de la cubierta del capó utilizando un tornillo para metales y una arandela pequeña negra.



7

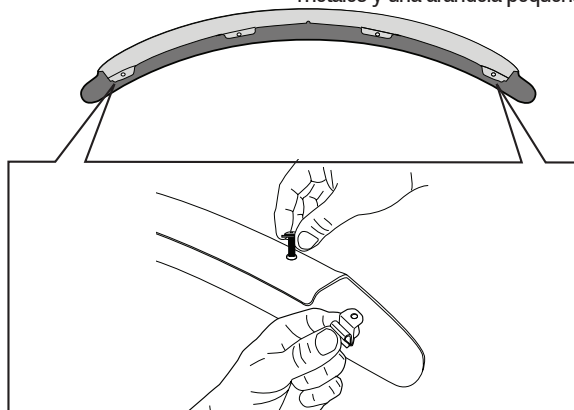

Pasos de instalación **NOTA:** La aplicación real tal vez no sea igual a las ilustraciones.

Coloque la cubierta del capó sobre su borde. Alinee los orificios. Deslice el soporte por el borde del capó y asegúrese de que esté centrado sobre la película protectora previamente colocada en el **Paso 5**.

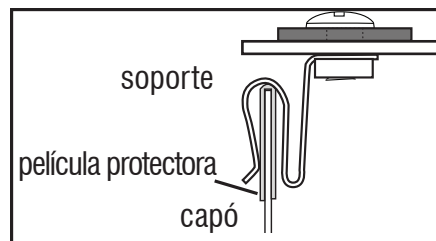
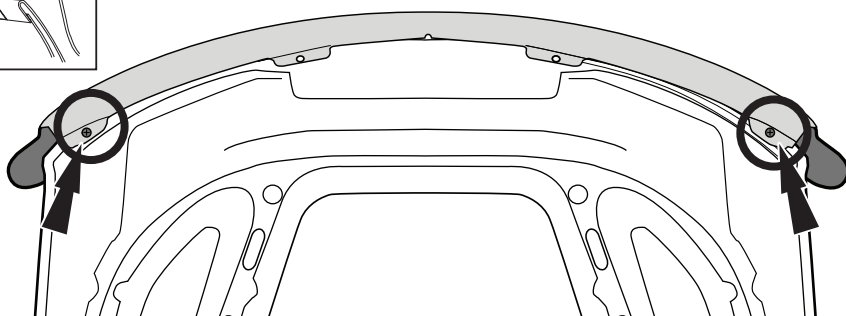

8

Coloque el tornillo con una arandela negra grande a través de los orificios **INTERIORES**. Ajústelo en los orificios guía anteriormente perforados en el **Paso 6**.

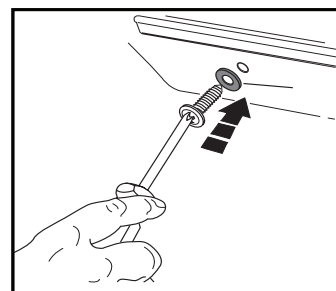
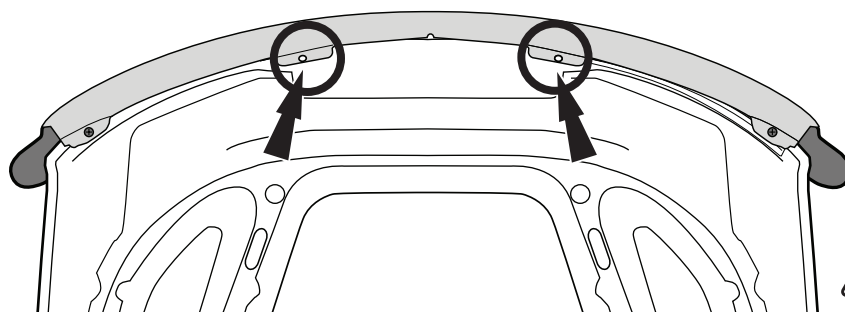

9

 **NO AJUSTE DEMASIADO**

Cierre el capó cuidadosamente.

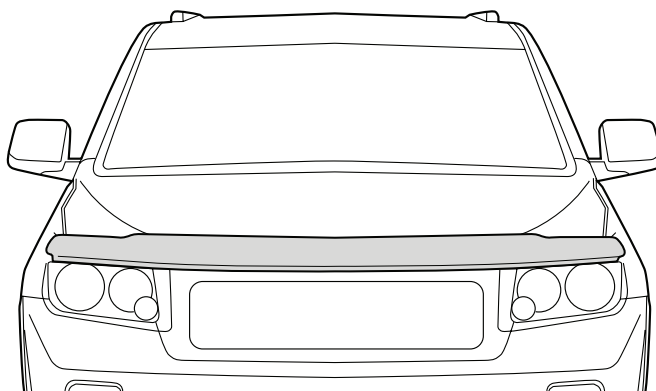

10

Cuidado y limpieza

- Lave sólo con jabón suave y seque con un paño limpio.

Felicidades

Usted ha adquirido uno de los tantos productos de calidad de marca Lund® que ofrece Lund International, Inc. Nos enorgullecen mucho nuestros productos y deseamos que disfrute años de satisfacción por su inversión. Nos hemos esforzado mucho para asegurarnos de que su producto sea de gran calidad en cuanto a ajuste, durabilidad, acabado y facilidad de instalación.



Lund International, Lund Accessories Division
4325 Hamilton Mill Rd. Suite 400, Buford, GA 30518
800-328-5863 • Visitenos en lundinternational.com

© 2011 Lund International, Inc. Todos los derechos reservados.
Lund® y el logo de Lund® son marcas registradas de Lund International, Inc.

