



Interceptor™

**For proper installation and best possible fit, please read all instructions BEFORE you begin.
For technical assistance or to obtain missing parts, please call Customer Relations at 1-800-241-7219.**

Important Safety Information



- CAUTION - Before driving, ensure that the hood shield is properly anchored to vehicle.
- Do not use automatic "brush-style" car washes.
- Do not use cleaning solvents of any kind.
- Periodically check all components for tightness.

Contents

NOTE: Actual product may vary from illustration.



Hood Shield

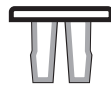

Hood Insert x4

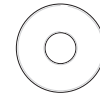

Washer x4



Screw x4

Tools Required



Car Wash Supplies

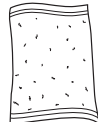

Clean Towel

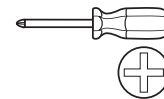

Appropriate hand tools

Preparation Before Painting / Installation

- A trial fit is recommended to ensure proper positioning and fit.
- Check fit of parts before painting as we will not accept the return of modified or painted parts.
- Wash and dry your vehicle to remove any debris and/or dirt from the installation area.

Installation Steps

NOTE: Actual application may vary slightly from illustrations.

Open Hood.

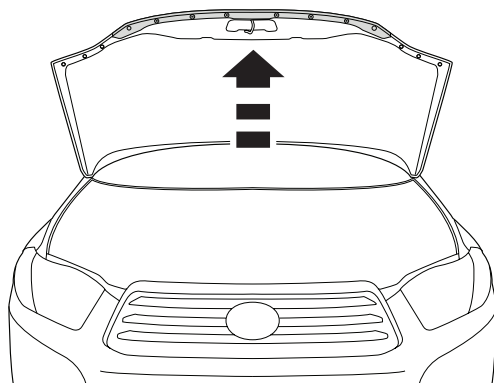

1

Note (4) positions along weatherstrip in between factory fasteners.

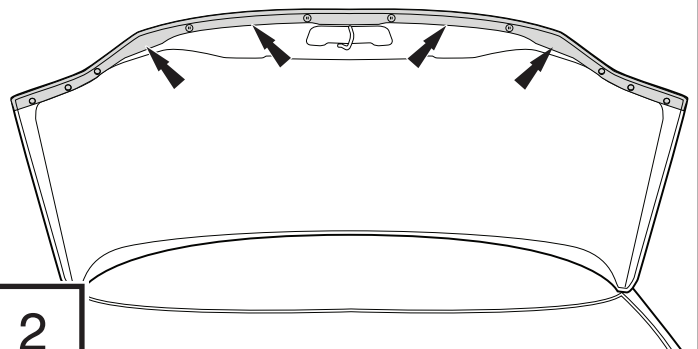

2

Installation Steps

NOTE: Actual application may vary slightly from illustrations.



Gently pull the weatherstrip down, and install (4) hood inserts in hood, **UNDERNEATH** the weatherstrip.

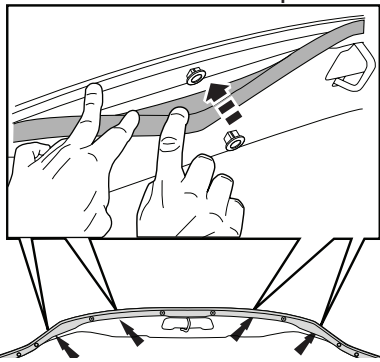

3

Center part on front edge of hood and align holes.
NOTE: flanges should be **UNDER** weatherstrip.

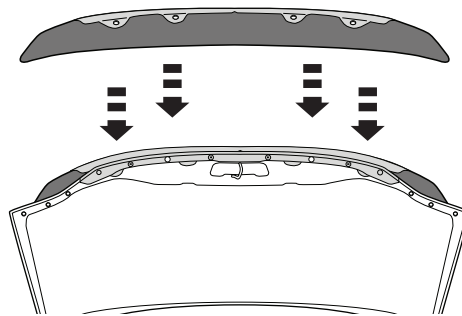

4



5

Install (4) screws with washers on the flanges.

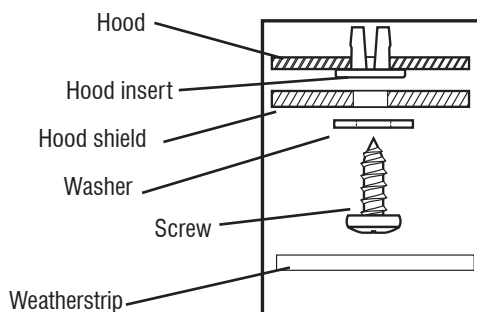
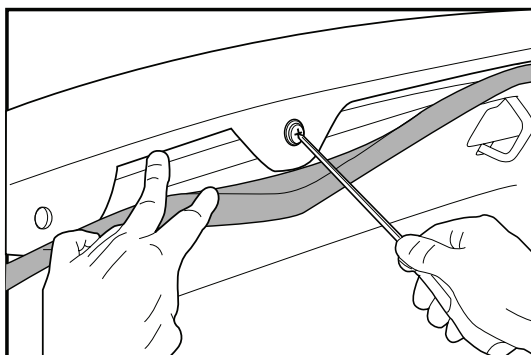

Care and Cleaning

- Wash only with mild soap & dry with a clean cloth.

Congratulations!

You have purchased one of the many quality Lund[®] branded products offered by Lund International, Inc. We take the utmost pride in our products and want you to enjoy years of satisfaction from your investment. We have made every effort to ensure that your product is top quality in terms of fit, durability, finish and ease of installation.

LUND[®]

Lund International

800-241-7219 • Visit us at lundinternational.com

© 2012 Lund International, Inc. All rights reserved.

Lund[®] and the Lund[®] logo are trademarks of Lund International, Inc.



Interceptor™

Pour obtenir une installation correcte et le meilleur ajustement possible, lire toutes les instructions **AVANT** de commencer. Pour toute assistance technique ou obtention de pièces manquantes, appeler le service des relations avec la clientèle au 1-800-241-7219.

Informations importantes concernant la sécurité



- ATTENTION – Avant de conduire, s'assurer que le pare-insectes est solidement assujéti sur le véhicule.
- Ne pas utiliser les stations de lavage de voitures à brosses.
- Ne pas utiliser de solvants.
- Vérifier régulièrement le serrage des composants.

Contenu **NOTE** : votre produit pourrait différer de l'illustration.



Protecteur de capot



4 espaceurs pour capot



4 rondelles



4 vis

Outils nécessaires



Équipement de nettoyage

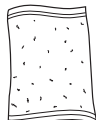

Linge propre

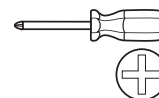

Outils appropriés

Préparation avant la peinture ou l'installation

- Effectuez un essai préalable afin de vérifier le bon positionnement et l'ajustement.
- Vérifiez la bonne pose des pièces avant de peindre car nous n'accepterons pas le renvoi de pièces modifiées ou peintes.
- Nettoyez et séchez votre véhicule afin d'éliminer les débris et/ou les poussières de la zone d'installation.

Étapes de l'installation **NOTE** : l'installation pourrait différer légèrement par rapport aux illustrations.

Ouvrez le capot.

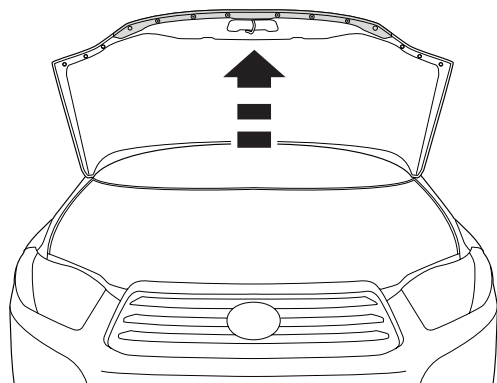

1

Notez les (4) positions le long du coupe-froid entre les fixations d'origine.

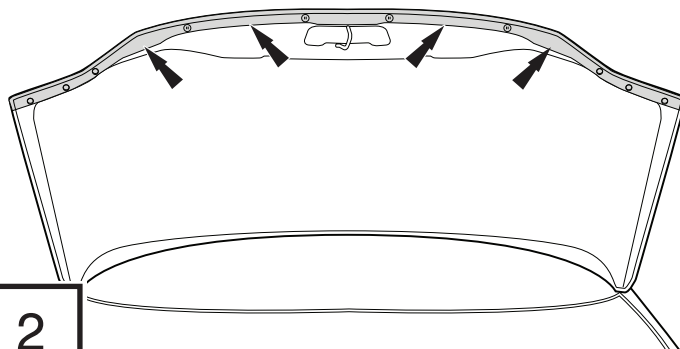

2

Étapes d'installation

REMARQUE : La méthode d'application peut être légèrement différente de celle représentée par les illustrations.



Tirez délicatement le coupe-froid vers le bas et installez les (4) espaceurs de capot **EN DESSOUS** du coupe-froid.

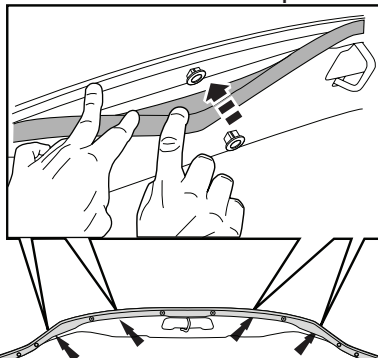

3

Centrez la pièce à l'avant du capot et alignez les orifices. **REMARQUE** : les rebords doivent être **AU-DESSOUS** du coupe-froid.

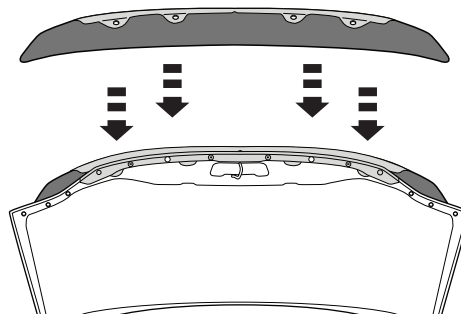

4

Installez les (4) vis avec des rondelles sur les rebords.

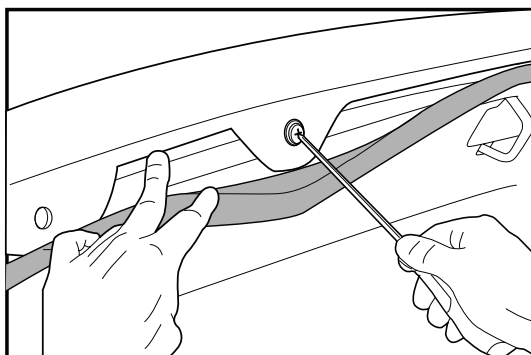

5

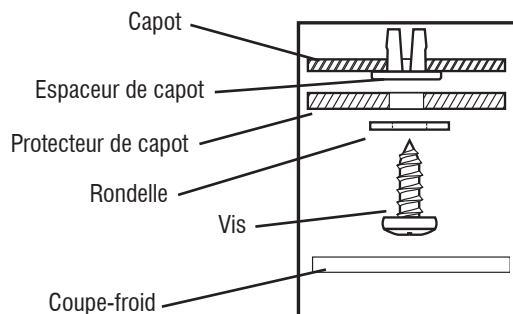

Entretien et nettoyage

- Laver exclusivement avec de l'eau savonneuse et sécher avec un chiffon propre.

Félicitations !

Vous venez d'acheter un des nombreux produits de qualité de la marque Lund® fabriqués par Lund International, Inc. Nous sommes extrêmement fiers de la qualité de nos produits et nous espérons que vous profiterez de cet investissement de longues années durant. Nous nous efforçons d'offrir la meilleure qualité en termes d'ajustement, de finition, de durabilité et de facilité d'installation.

LUND®

Lund International

800-241-7219 • Visitez notre site lundinternational.com

© 2012 Lund International, Inc. Tous droits réservés.

Lund® et le logo Lund® sont des marques déposées de Lund International, Inc.



LUND®

Interceptor™

Para una instalación adecuada y el mejor ajuste posible, lea todas las instrucciones ANTES de comenzar. Si desea recibir asistencia técnica u obtener piezas faltantes, llame al Servicio al cliente al 1-800-241-7219.

Información importante de seguridad



- **PRECAUCIÓN** - Antes de conducir, asegúrese de que la cubierta para capó esté correctamente anclada al vehículo.
- No utilice servicios automáticos de limpieza de vehículos que utilizan cepillos.
- No utilice limpiadores al solvente de ningún tipo.
- Compruebe periódicamente que todos los componentes estén ajustados.

Contenidos **NOTA:** El producto real puede diferir del de la ilustración.



Deflector de capó



4 accesorios de inserción del capó



4 arandelas



4 tornillos

Herramientas requeridas



Productos para el lavado de autos



Toalla limpia

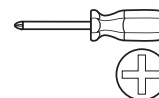

Herramientas manuales apropiadas

Preparación antes de la pintura / Instalación

- Se recomienda realizar una prueba de ajuste para garantizar una colocación y un ajuste correctos.
- Controle el ajuste de las piezas antes de pintar ya que no aceptaremos la devolución de piezas modificadas o pintadas.
- Lave y seque su vehículo para eliminar cualquier tipo de restos o suciedad de la superficie de instalación del deflector.

Pasos de la instalación **NOTA:** La colocación real puede ser un poco diferente a la indicada en las ilustraciones.

Abra el capó.

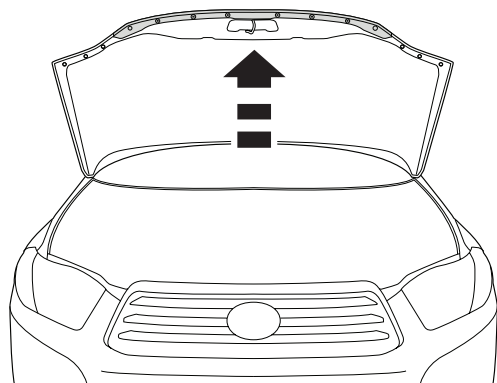

1

Note las (4) posiciones a lo largo del burlete entre los afianzadores de fábrica.

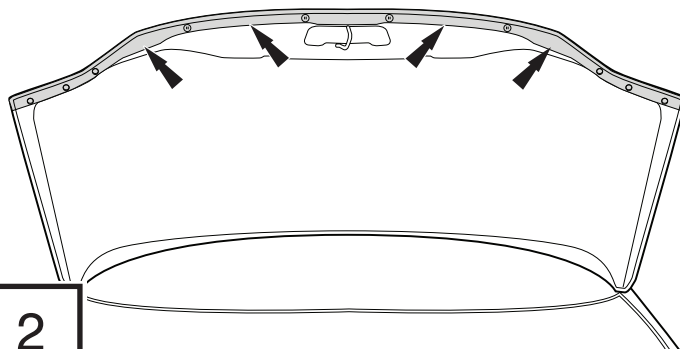

2

Pasos de instalación **AVISO:** La colocación real puede variar con respecto a las ilustraciones.



Tire delicadamente el burlete hacia abajo e instale los (4) insertos en el capó, **DEBAJO** del burlete.

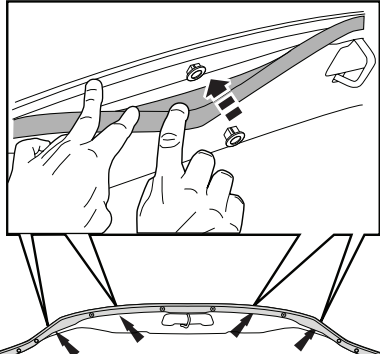

3

Centre la pieza en el borde delantero del capó y alinee los agujeros. **NOTA:** las alas deben estar **DEBAJO** del burlete.

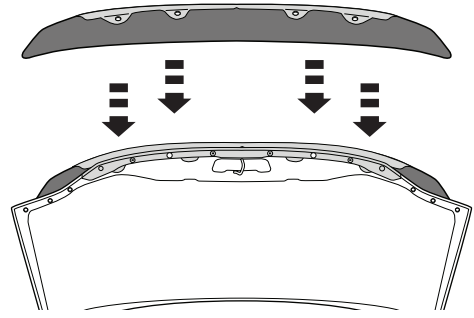

4

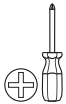

Instale (4) tornillos con arandelas en las alas.

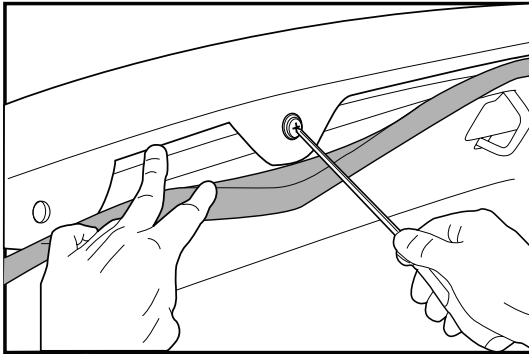

5

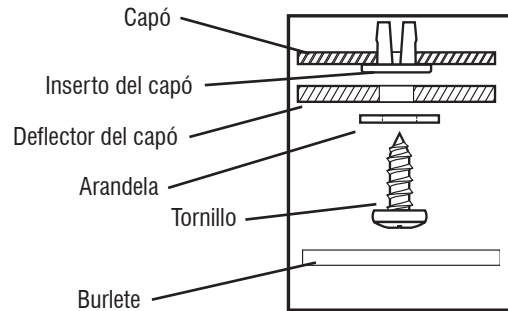

Cuidado y limpieza

- Limpie solamente con agua jabonosa tibia y seque con un paño limpio.

Felicidades

Usted ha adquirido uno de los tantos productos de calidad de marca Lund[®] que ofrece Lund International, Inc. Nos enorgullecen mucho nuestros productos y deseamos que disfrute años de satisfacción por su inversión. Nos hemos esforzado mucho para asegurarnos de que su producto sea de gran calidad en cuanto a ajuste, durabilidad, acabado y facilidad de instalación.

LUND[®]

Lund International

800-241-7219 • Visite nuestro sitio Web: lundinternational.com

© 2012 Lund International, Inc. Todos los derechos reservados.

Lund[®] y el logo de Lund[®] son marcas registradas de Lund International, Inc.

