



Interceptor™

For proper installation and best possible fit, please read all instructions BEFORE you begin. For technical assistance or to obtain missing parts, please call Customer Relations at 1-800-241-7219.

Important Safety Information



- CAUTION - Before driving, ensure that the hood shield is properly anchored to vehicle.
- Do not use automatic "brush-style" car washes.
- Do not use cleaning solvents of any kind.
- Periodically check all components for tightness.

Contents **NOTE:** Actual product may vary from illustration.



Hood shield



Screw x4
(98027)



Washer x4
(98026)



Insert x4
(98025)



Alcohol Pad x2

Tools Required



Car Wash Supplies

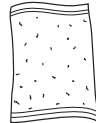

Clean Towel

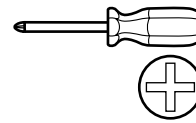

Phillips screw-
driver

Preparation Before Painting / Installation

- A trial fit is recommended to ensure proper positioning and fit.
- Check fit of parts before painting as we will not accept the return of modified or painted parts.
- Wash and dry your vehicle to remove any debris and/or dirt from the installation area.

Installation Steps **NOTE:** Actual application may vary slightly from illustrations.

Raise hood.

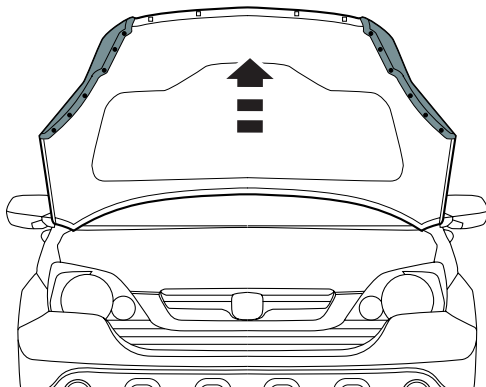

1



Locate (4) square holes on the underside of hood. Clean the area around these with a soft cloth. Install (1) insert in each square hole

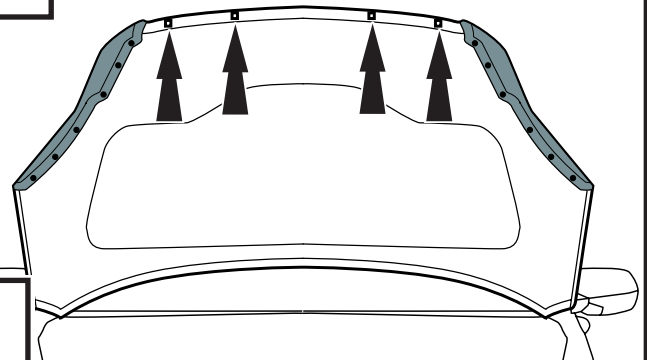

2

Installation Steps

NOTE: Actual application may vary slightly from illustrations.

Alcohol Pad

Gently pull the rubber trim pieces back in (2) places and clean underneath with an alcohol pad.

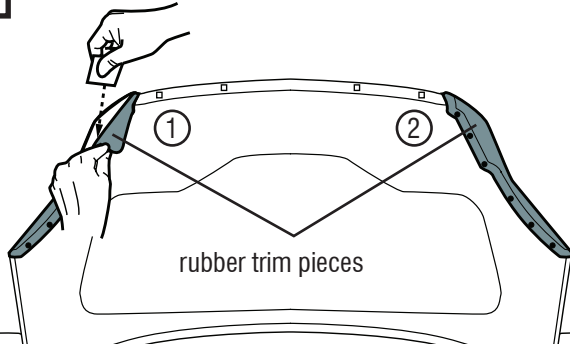

3

Remove tape liner from each end of the outboard flanges.

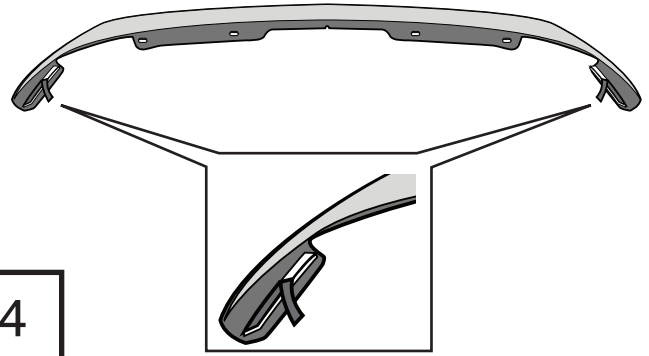

4

Center part on front edge of hood and align holes. Slide the outboard flanges **UNDER** the rubber trim pieces.

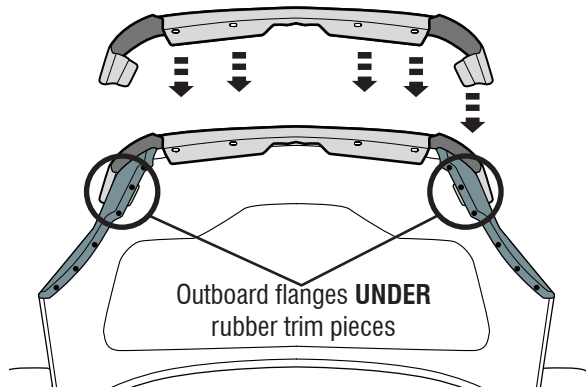

5

Place a washer over a screw and insert through hood shield and into hood. Repeat for remaining holes. Tighten screws.

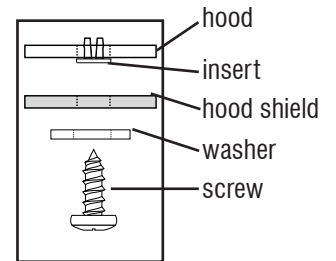
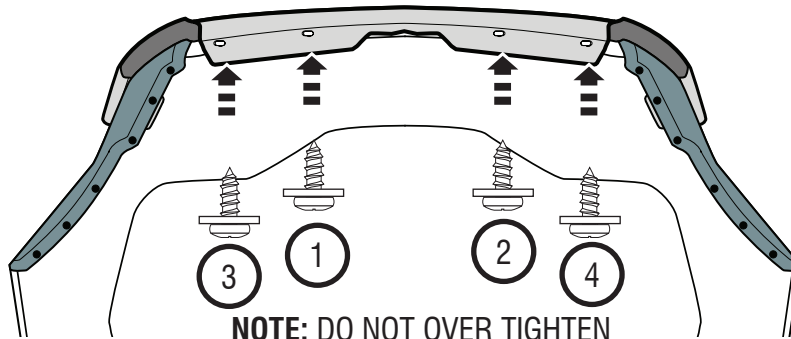
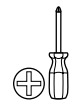

6

Apply pressure to outboard flanges to ensure adhesion of taped surfaces to hood surface.

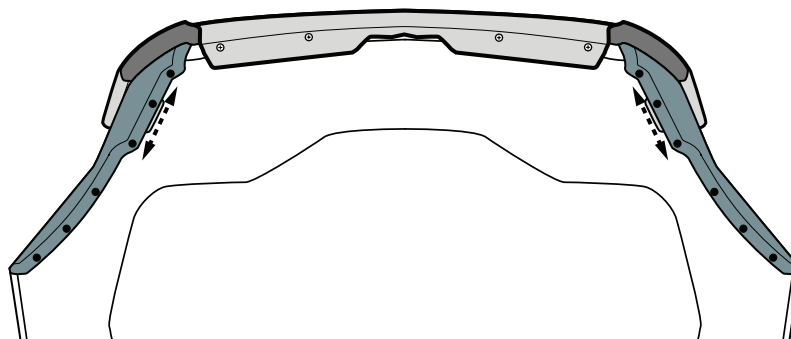

7

Installation Steps

NOTE: Actual application may vary slightly from illustrations.

Close Hood.

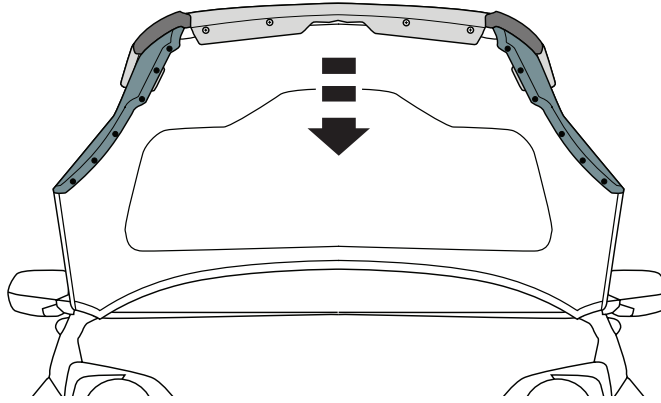

8

Care and Cleaning

- Wash only with mild soap & dry with a clean cloth.

Congratulations!

You have purchased one of the many quality Lund® branded products offered by Lund International, Inc. We take the utmost pride in our products and want you to enjoy years of satisfaction from your investment. We have made every effort to ensure that your product is top quality in terms of fit, durability, finish and ease of installation.

LUND®

Lund International

800-241-7219 • Visit us at lundinternational.com

© 2012 Lund International, Inc. All rights reserved.

Lund® and the Lund® logo are trademarks of Lund International, Inc.



LUND®

Interceptor™

Pour obtenir une installation correcte et le meilleur ajustement possible, lire toutes les instructions AVANT de commencer.

Pour toute assistance technique ou obtention de pièces manquantes, appeler le service des relations avec la clientèle au 1-800-241-7219.

Informations importantes concernant la sécurité



- ATTENTION – Avant de conduire, s'assurer que le pare-insectes est solidement assujéti sur le véhicule.
- Ne pas utiliser les stations de lavage de voitures à brosses.
- Ne pas utiliser de solvants.
- Vérifier régulièrement le serrage des composants.

Contenu

REMARQUE : Le produit peut être différent de celui représenté sur l'illustration.



Protection de capot



4 vis



4 rondelles



4 espaceurs



2 tampons d'alcool

Outils nécessaires



Fournitures pour lavage de voiture

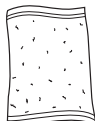

Serviette propre

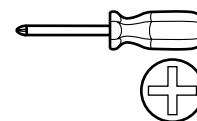

Tournevis cruciforme

Préparation pour la peinture/l'installation

- Il est recommandé de procéder à un essai pour s'assurer que le positionnement et l'ajustement sont corrects.
- Vérifier l'ajustement des pièces avant peinture, car nous n'acceptons pas le retour de pièces modifiées ou peintes.
- Laver le véhicule pour éliminer toute poussière et tous débris.
- Sécher le capot avec une serviette propre.

Étapes d'installation

REMARQUE : La méthode d'application peut être légèrement différente de celle représentée par les illustrations.

Soulevez le capot.

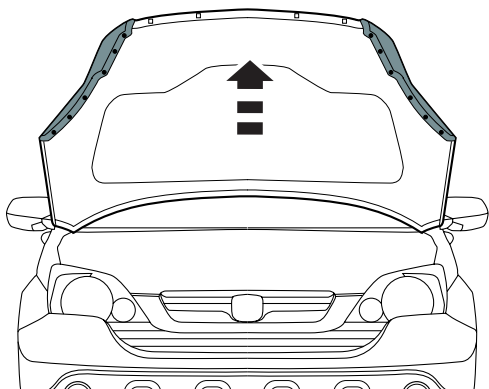

1



Localisez les (4) orifices carrés sur la partie inférieure du capot. Nettoyez la surface autour des orifices avec un chiffon doux. Installez (1) espaceur dans chaque orifice carré.

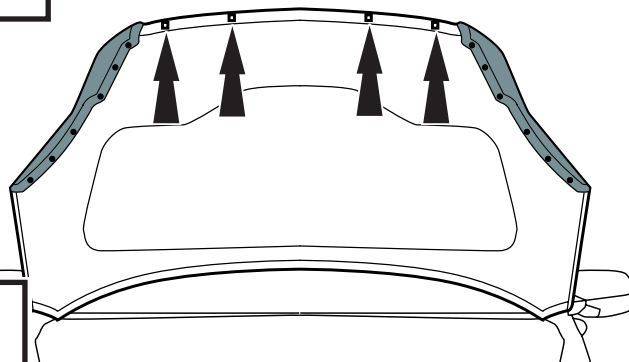

2

Étapes d'installation

REMARQUE : La méthode d'application peut être légèrement différente de celle représentée par les illustrations.

Alcohol Pad

Tirez délicatement sur la garniture en caoutchouc à (2) endroits et nettoyez en dessous avec un tampon d'alcool.

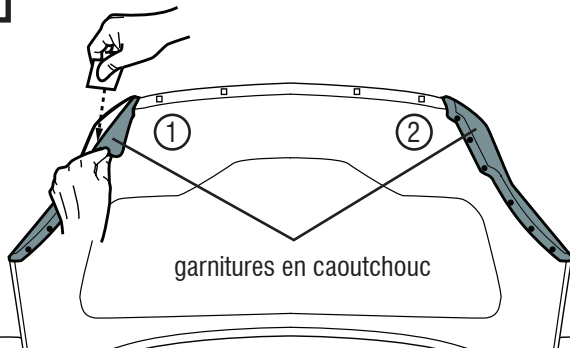

3

Enlevez la bande autocollante à chaque extrémité des rebords extérieurs.

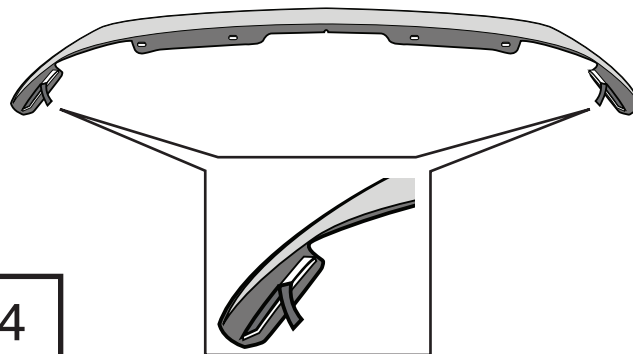

4

Centrez la pièce à l'avant du capot et alignez les orifices. Glissez les rebords extérieurs **SOUS** les garnitures en caoutchouc.

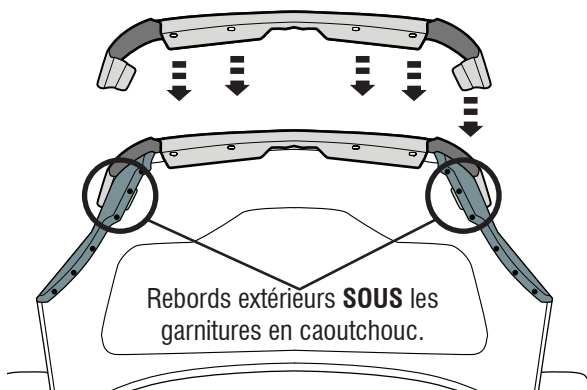

5

Placez une rondelle sur une vis et insérez-la à travers la protection de capot et le capot. Répétez la même procédure pour les orifices restants. Serrez les vis.

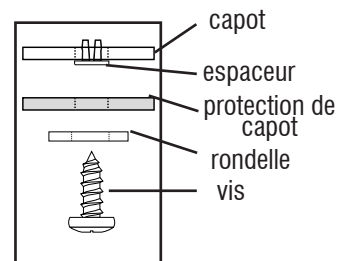
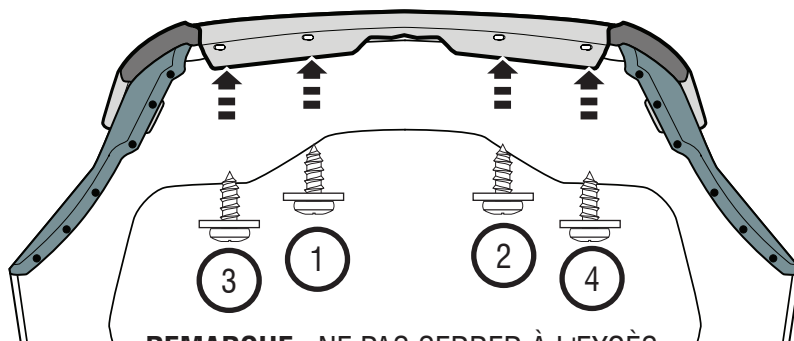
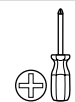

6

REMARQUE : NE PAS SERRER À L'EXCÈS

Appliquez une pression sur les rebords extérieurs pour vous assurer que les surfaces autocollantes adhèrent à la surface du capot.

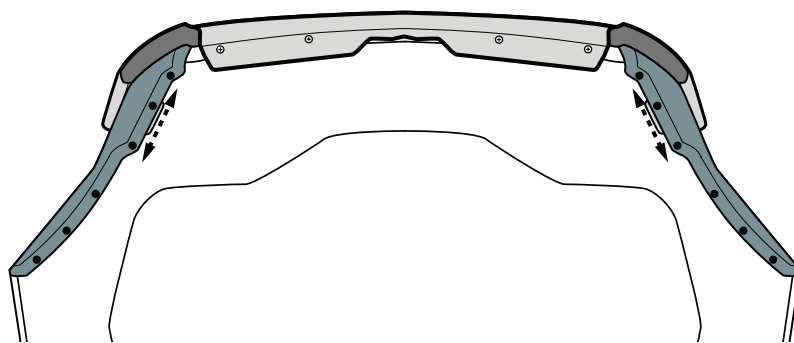

7

Étapes d'installation

REMARQUE : La méthode d'application peut être légèrement différente de celle représentée par les illustrations.

Fermez le capot.

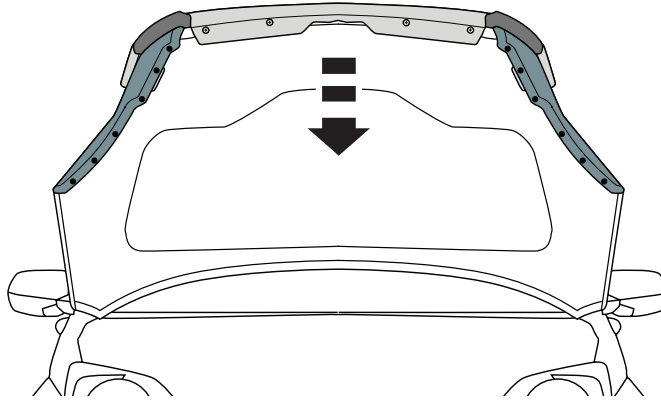

8

Entretien et nettoyage

- Laver exclusivement avec de l'eau savonneuse et sécher avec un chiffon propre.

Félicitations !

Vous venez d'acheter un des nombreux produits de qualité de la marque Lund[®] fabriqués par Lund International, Inc. Nous sommes extrêmement fiers de la qualité de nos produits et nous espérons que vous profiterez de cet investissement de longues années durant. Nous nous efforçons d'offrir la meilleure qualité en termes d'ajustement, de finition, de durabilité et de facilité d'installation.

LUND[®]

Lund International

800-241-7219 • Visitez notre site lundinternational.com

© 2012 Lund International, Inc. Tous droits réservés.

Lund[®] et le logo Lund[®] sont des marques déposées de Lund International, Inc.



LUND®

Interceptor™

Para una instalación adecuada y el mejor ajuste posible, lea todas las instrucciones ANTES de comenzar. Si desea recibir asistencia técnica u obtener piezas faltantes, llame al Servicio al cliente al 1-800-241-7219.

Información importante de seguridad



- **PRECAUCIÓN** - Antes de conducir, asegúrese de que la cubierta para capó esté correctamente anclada al vehículo.
- No utilice servicios automáticos de limpieza de vehículos que utilizan cepillos.
- No utilice limpiadores al solvente de ningún tipo.
- Compruebe periódicamente que todos los componentes estén ajustados.

Contenido **AVISO:** El producto real puede variar con respecto a las ilustraciones.



Cubierta del capó



Tornillo x4
(98027)



Arandela x4
(98026)



Inserto x4
(98025)



Paño con alcohol x2

Herramientas necesarias



Equipo de limpieza de vehículos



Toalla limpia

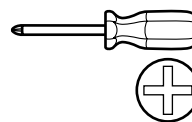

Destornillador de cabeza Phillips

Preparación antes de pintar o instalar

- Se recomienda realizar un ajuste de prueba para asegurar el posicionamiento y ajuste correctos.
- Compruebe que las piezas se ajusten correctamente antes de pintarlas, ya que no aceptaremos la devolución de piezas modificadas o pintadas.
- Lave el capó del vehículo para quitar los desechos y la suciedad.
- Seque el capó con una toalla limpia.

Pasos de instalación **AVISO:** La colocación real puede variar con respecto a las ilustraciones.

Levante el capó.

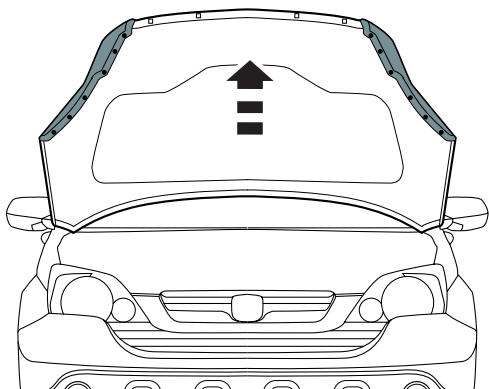

1



Encuentre los cuatro (4) orificios cuadrados en la parte inferior del capó. Limpie el área que los rodea con un paño suave. Coloque un (1) inserto en cada orificio cuadrado.

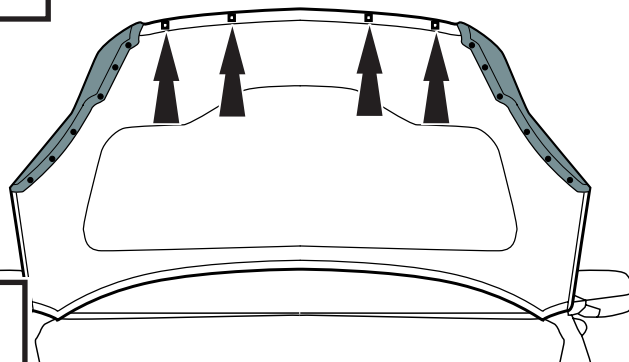

2

Pasos de instalación **AVISO:** La colocación real puede variar con respecto a las ilustraciones.

Alcohol Pad

Tire de las bandas de caucho con suavidad hacia atrás en las dos (2) ubicaciones y limpie debajo con un paño con alcohol.

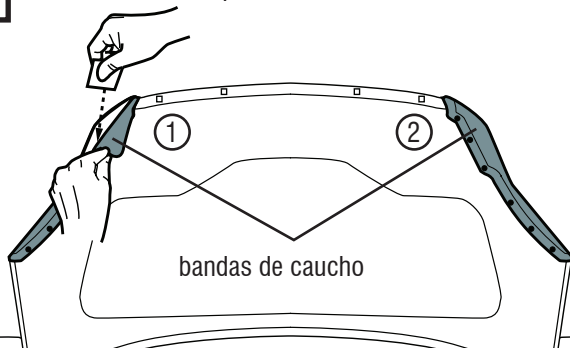

3

Quite la cinta protectora de cada extremo de los rebordes externos.

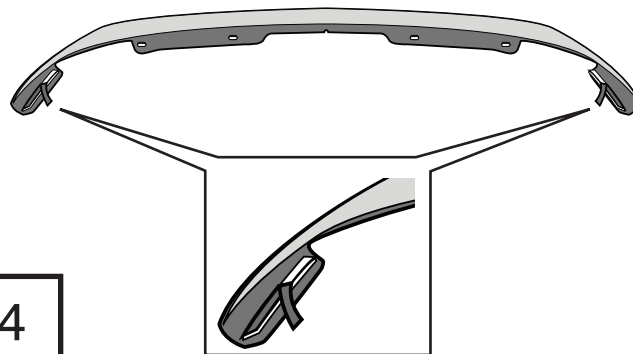

4

Centre la pieza en el borde delantero del capó y alinee los agujeros. Deslice los rebordes externos **DEBAJO** de las bandas de caucho.



5

Coloque una arandela sobre un tornillo e inserte el tornillo a través de la cubierta del capó y dentro de este. Repita la operación con los orificios restantes. Ajuste los tornillos.

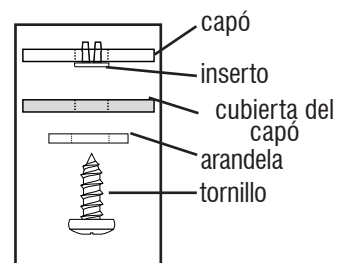
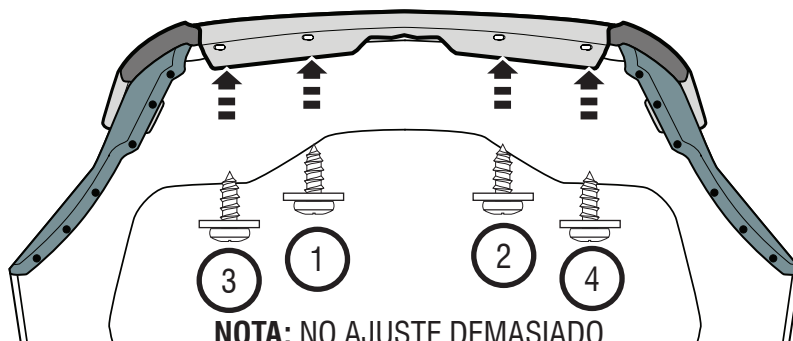
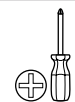

6

NOTA: NO AJUSTE DEMASIADO.

Aplique presión en los rebordes externos para que las superficies con cinta se adhieran a la superficie del capó.

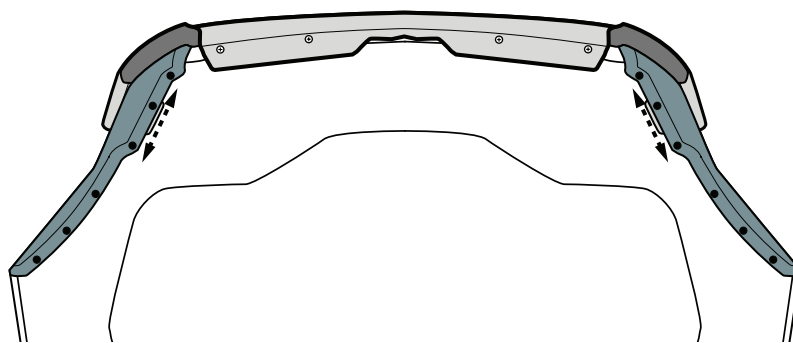

7

Cierre el capó.

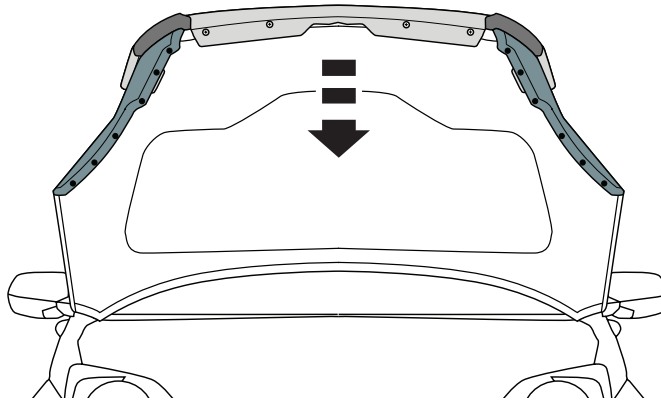

8

Cuidado y limpieza

- Limpie solamente con agua jabonosa tibia y seque con un paño limpio.

Felicidades

Usted ha adquirido uno de los tantos productos de calidad de marca Lund[®] que ofrece Lund International, Inc. Nos enorgullecen mucho nuestros productos y deseamos que disfrute años de satisfacción por su inversión. Nos hemos esforzado mucho para asegurarnos de que su producto sea de gran calidad en cuanto a ajuste, durabilidad, acabado y facilidad de instalación.

LUND[®]

Lund International

800-241-7219 • Visite nuestro sitio Web: lundinternational.com

© 2012 Lund International, Inc. Todos los derechos reservados.

Lund[®] y el logo de Lund[®] son marcas registradas de Lund International, Inc.

