



Interceptor™

**For proper installation and best possible fit, please read all instructions BEFORE you begin.
For technical assistance or to obtain missing parts, please call Customer Relations at 1-800-241-7219.**

Important Safety Information



- CAUTION - Before driving, ensure that the hood shield is properly secured to vehicle.
- Do not use automatic "brush-style" car washes.
- Do not use cleaning solvents of any kind.
- Periodically check all components for tightness.

Contents

NOTE: Actual product may vary from illustration.



Hood shield



Screw x4



Bump ons
x3



Alcohol
Pad

Tools Required



Car Wash Supplies

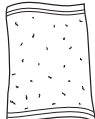

Clean Towel



Phillips screwdriver

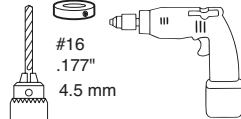

Drill and bit, stop collar



Safety glasses



Pen



Center punch



Hammer



Anti corrosion agent

Preparation Before Painting / Installation

- A trial fit is recommended to ensure proper positioning and fit.
- Check fit of parts before painting as we will not accept the return of modified or painted parts.
- Wash and dry your vehicle to remove any debris and/or dirt from the installation area.

Installation Steps

NOTE: Actual application may vary slightly from illustrations.



Clean leading edge of hood thoroughly and dry with a soft cloth.

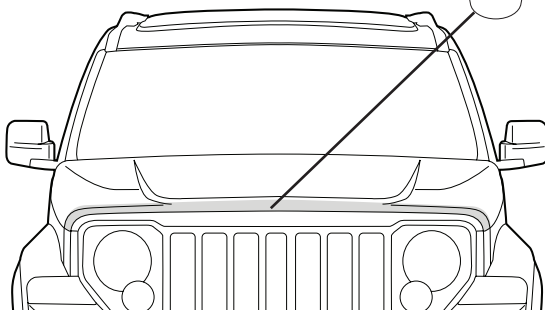

1

Open hood.

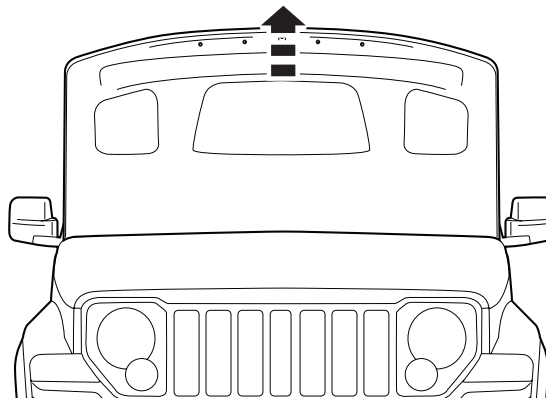

2

Installation Steps

NOTE: Actual application may vary slightly from illustrations.

Carefully center hood shield on hood edge.

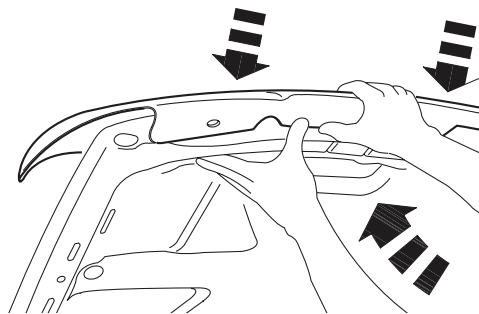
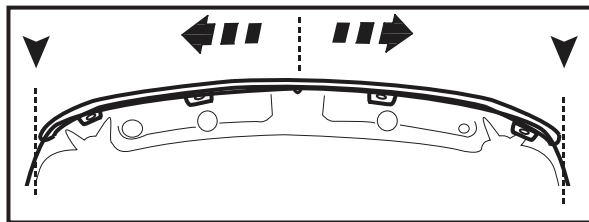

3

Use a pen to indicate the four (4) locations where the holes in hood shield align on the hood.



X4

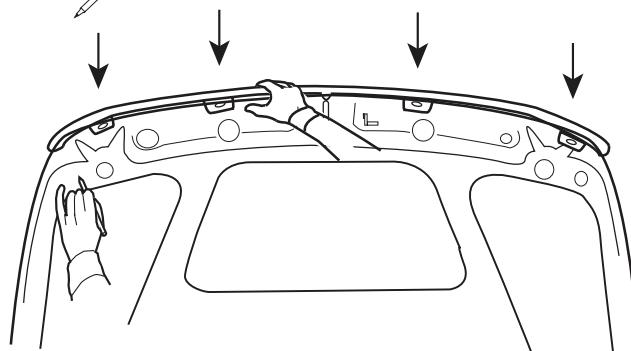

4

Carefully set hood shield aside. Use a hammer and center punch to mark the points made in **Step 5** in preparation for drilling. **Carefully** use a drill fitted with a #16 bit (.177" / 4.5 mm) and a stop collar to drill a 1/8" (3 mm) hole in the hood. After drilling, apply an anti corrosion agent to the hole. Repeat for remaining holes.

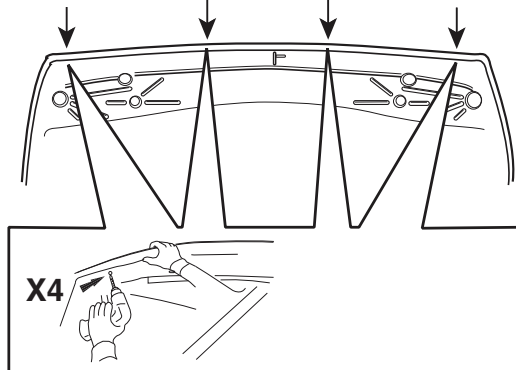
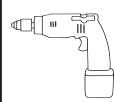
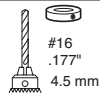

X4

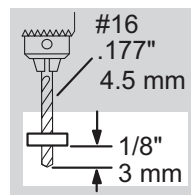

CAUTION: DO NOT DRILL THROUGH HOOD TO OPPOSITE SIDE.

5

Reposition hood shield on hood edge, aligning the holes in the hood shield with the holes drilled in **Step 6**. Insert a screw through each hole and secure hood shield to hood. **NOTE: DO NOT OVERTIGHTEN.**

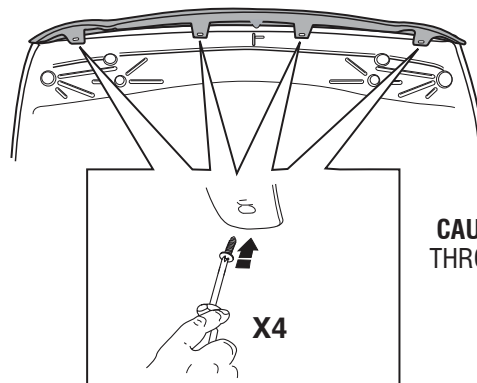

X4



CAUTION: DO NOT PUSH SCREW THROUGH TO THE OPPOSITE SIDE OF THE HOOD.

6

Installation Steps

NOTE: Actual application may vary slightly from illustrations.

Alcohol Pad

Close the hood and use an alcohol pad to clean the locations on the hood surface indicated.

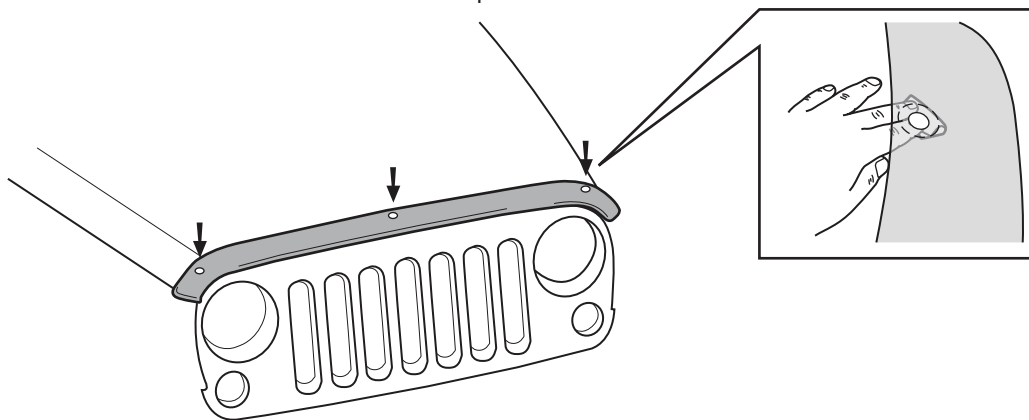

7



Remove cover from adhesive backing on the bottom of the three (3) bump ons, and apply to the locations cleaned in **Step 7**.

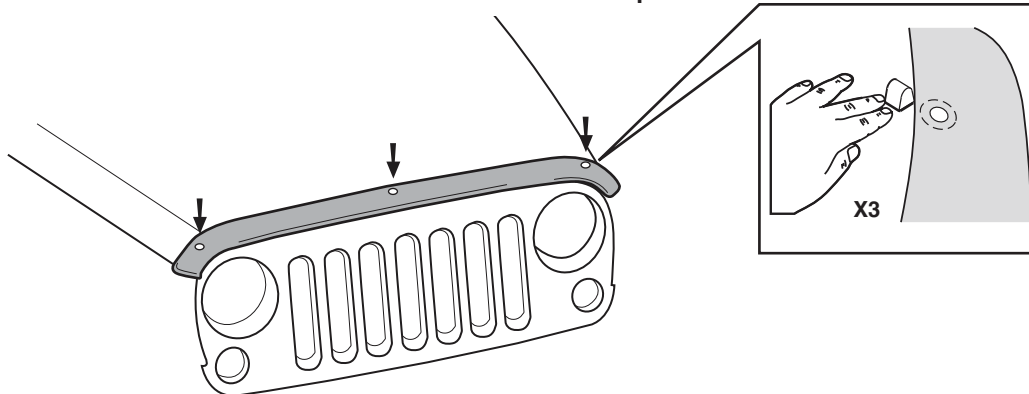

8

Care and Cleaning

- Wash only with mild soap & dry with a clean cloth.

Congratulations!

You have purchased one of the many quality Lund[®] branded products offered by Lund International, Inc. We take the utmost pride in our products and want you to enjoy years of satisfaction from your investment. We have made every effort to ensure that your product is top quality in terms of fit, durability, finish and ease of installation.

LUND[®]

Lund International

800-241-7219 • Visit us at lundinternational.com

© 2012 Lund International, Inc. All rights reserved.

Lund[®] and the Lund[®] logo are trademarks of Lund International, Inc.



LUND®

Interceptor™

Pour obtenir une installation correcte et le meilleur ajustement possible, lire toutes les instructions AVANT de commencer. Pour toute assistance technique ou obtention de pièces manquantes, appeler le service des relations avec la clientèle au 1-800-241-7219.

Informations importantes concernant la sécurité



- ATTENTION – Avant de conduire, s'assurer que le pare-insectes est solidement assujettie sur le véhicule.
- Ne pas utiliser les stations de lavage de voitures à brosse.
- Ne pas utiliser de solvants.
- Vérifier régulièrement le serrage des composants.

Contenu NOTE: Le produit réel peut changer de l'illustration.



Protection de capot



4 vis



3 grommes



Tampon d'alcool

Outils nécessaires



Équipement de nettoyage

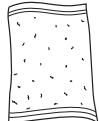

Linge propre

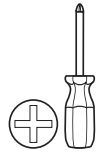

Tournevis Phillips

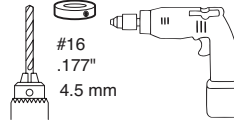

Perceuse et mèche, collier de butée



Lunettes de protection



Stylo



Pointeau



Marteau



Agent anticorrosif

Préparation pour la peinture/l'installation

- Il est recommandé de procéder à un essai pour s'assurer que le positionnement et l'ajustement sont corrects.
- Vérifier l'ajustement des pièces avant peinture, car nous n'acceptons pas le retour de pièces modifiées ou peintes.
- Laver les glissières de glaces de la portière du véhicule pour éliminer toute poussière et tous débris.
- Sécher les glissières avec une serviette propre.

Étapes d'installation

REMARQUE : La méthode d'application peut être légèrement différente de celle représentée par les illustrations.



Nettoyez à fond le bord d'attaque du capot puis séchez avec un chiffon doux.

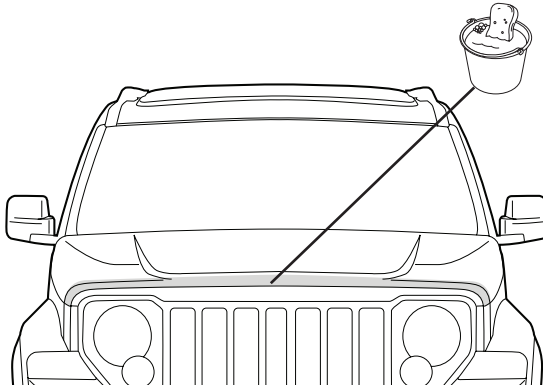

1

Ouvrez le capot.

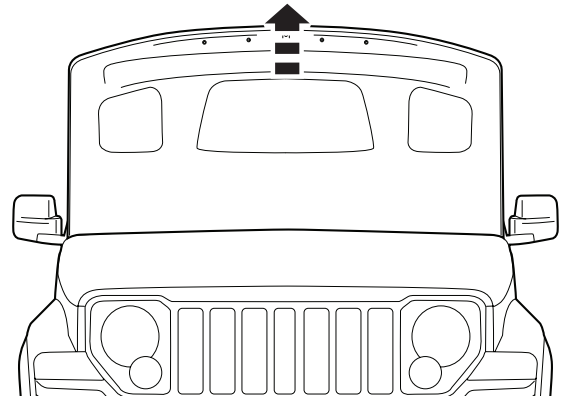

2

Étapes d'installation

REMARQUE : La méthode d'application peut être légèrement différente de celle représentée par les illustrations.

Centrez la protection de capot sur le bord du capot.

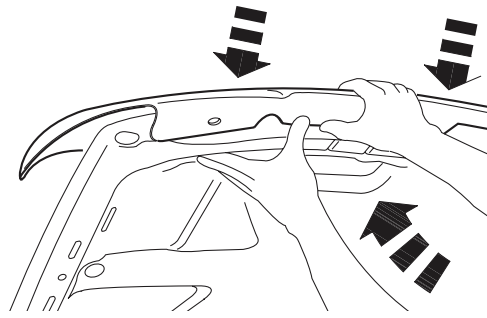
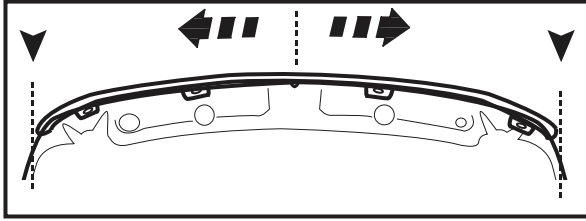

3



À l'aide d'un stylo, marquez sur le capot les quatre (4) emplacements correspondant aux trous présents sur la protection de capot.

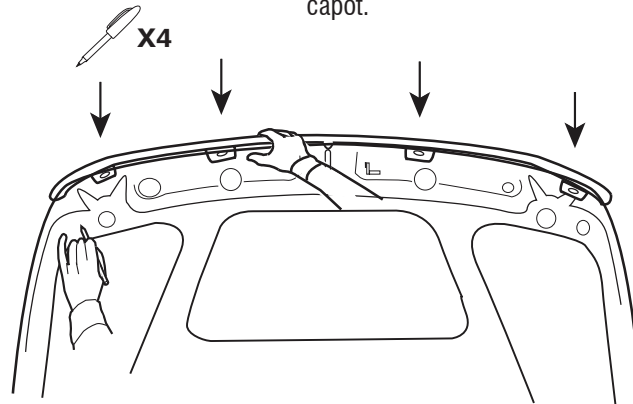

4



Mettez de côté la protection de capot avec précaution. Utilisez un marteau et un pointeau pour marquer les points effectués à l'Étape 4, afin de préparer le percement des trous. À l'aide d'une perceuse équipée d'une mèche n°16 (0,177 po / 4,5 mm) et d'un collier de butée, percez avec précaution un trou de 1/8 po (3 mm) dans le capot. Après avoir percé le trou, appliquez un agent anticorrosif sur le trou. Répétez l'opération pour les trous restants.

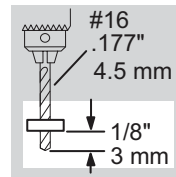
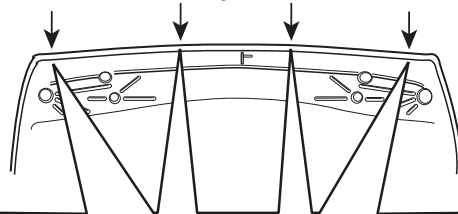

ATTENTION : NE PAS PERCER LE CAPOT DE PART EN PART.

5

X4

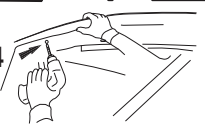

Repositionnez la protection de capot sur le bord du capot, en alignant les trous de la protection avec les trous percés à l'Étape 5. Insérez une vis dans chacun des trous et vissez fermement la protection au capot. **REMARQUE : NE PAS SERRER À L'EXCÈS.**

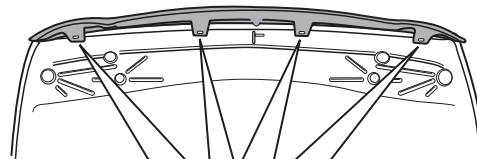

ATTENTION : NE PAS ENFONCER LES VIS JUSQU'À L'AUTRE CÔTÉ DU CAPOT.

6

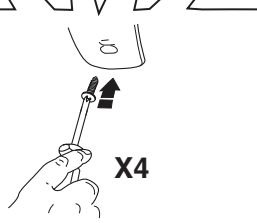

Étapes d'installation

REMARQUE : La méthode d'application peut être légèrement différente de celle représentée par les illustrations.

Alcohol
Pad

Fermez le capot et utilisez un tampon d'alcool pour nettoyer les emplacements indiqués sur la surface du capot.

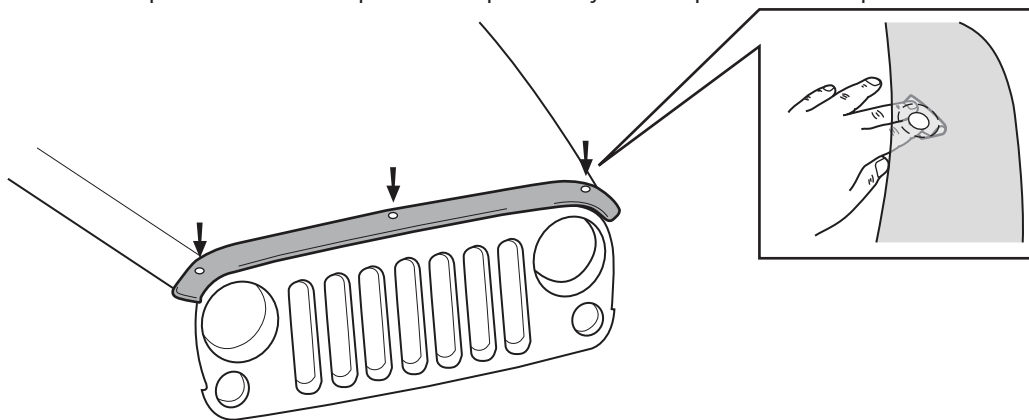

7



Défaitez la protection arrière adhésive sur la partie inférieure des trois (3) gommes et appliquez-les sur les emplacements nettoyés à l'Étape 7.

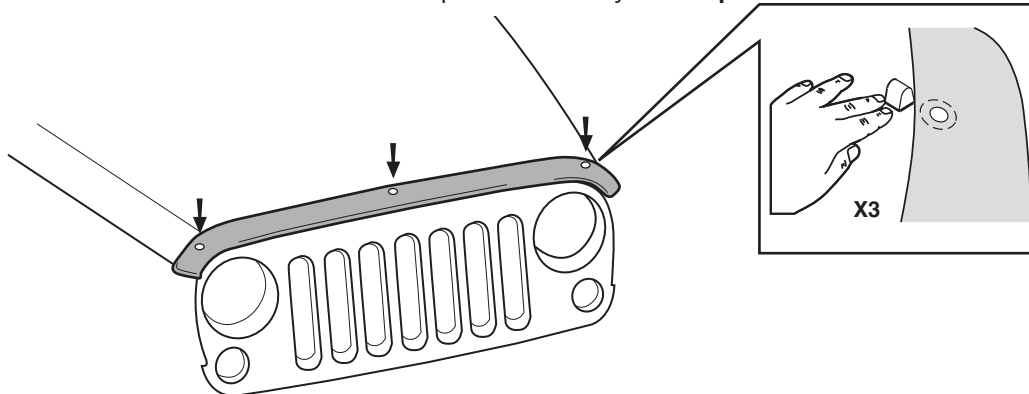

8

Entretien et nettoyage

- Laver exclusivement avec de l'eau savonneuse et sécher avec un chiffon propre.

Félicitations !

Vous venez d'acheter un des nombreux produits de qualité de la marque Lund[®] fabriqués par Lund International, Inc. Nous sommes extrêmement fiers de la qualité de nos produits et nous espérons que vous profiterez de cet investissement de longues années durant. Nous nous efforçons d'offrir la meilleure qualité en termes d'ajustement, de finition, de durabilité et de facilité d'installation.

LUND[®]

Lund International

800-241-7219 • Visitez notre site lundinternational.com

© 2012 Lund International, Inc. Tous droits réservés.

Lund[®] et le logo Lund[®] sont des marques déposées de Lund International, Inc.



LUND®

Interceptor™

Para una instalación adecuada y el mejor ajuste posible, lea todas las instrucciones ANTES de comenzar. Si desea recibir asistencia técnica u obtener piezas faltantes, llame al Servicio al cliente al 1-800-241-7219.

Información importante de seguridad



- **PRECAUCIÓN** - Antes de conducir, asegúrese de que la visera deflectora esté correctamente anclada al vehículo.
- No utilice servicios automáticos de limpieza de vehículos que utilizan cepillos.
- No utilice limpiadores al solvente de ningún tipo.
- Compruebe periódicamente que todos los componentes estén ajustados.

Contenido

NOTA: El producto real puede variar de la ilustración.



Cubierta del capó



Tornillo x 4



Topes de goma x 3



Paño con alcohol

Herramientas necesarias



Equipo de limpieza de vehículos



Toalla limpia

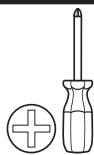

Destornillador Phillips

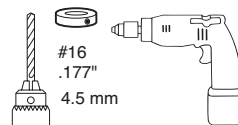

Taladro y broca, collarín de tope



Gafas de seguridad



Lápiz



Punzón



Martillo



Agente anticorrosivo

Preparación antes de pintar o instalar

- Se recomienda realizar un ajuste de prueba para asegurar el posicionamiento y ajuste correctos.
- Compruebe que las piezas se ajusten correctamente antes de pintarlas, ya que no aceptaremos la devolución de piezas modificadas o pintadas.
- Lave los canales de la ventanilla del vehículo para quitar los desechos y la suciedad.
- Seque los canales de la ventanilla con una toalla limpia.

Pasos de instalación

NOTA: El uso real puede variar levemente de ilustraciones.



Limpie bien el borde anterior del capó y seque con un paño suave.

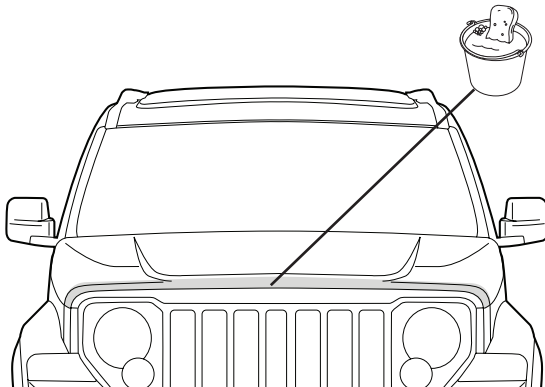

1

Abra el capó.

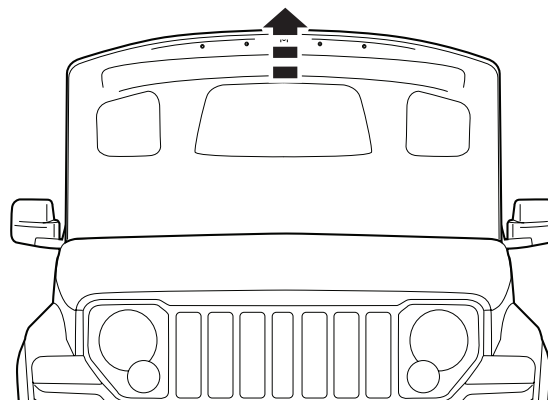

2

Pasos de instalación

NOTA: El uso real puede variar levemente de ilustraciones.

Centre cuidadosamente la cubierta del capó sobre el borde del capó.

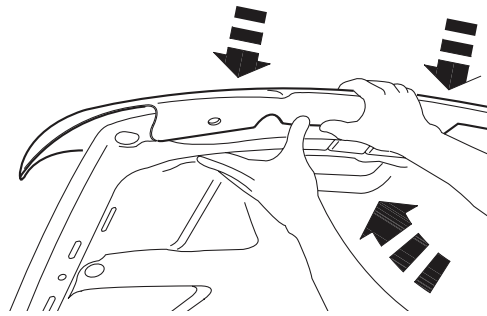
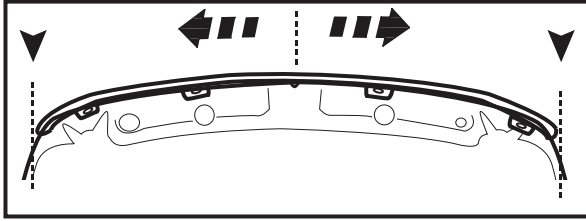

3



Use un lápiz para marcar los cuatro (4) puntos donde los orificios de la cubierta del capó queden alineados sobre el capó.

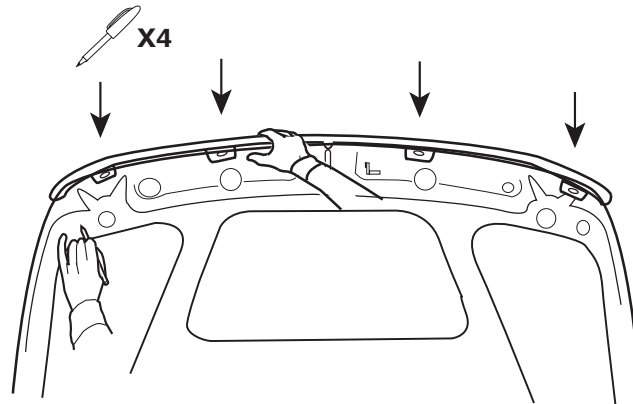

4



Separe cuidadosamente la cubierta del capó. Use el martillo y el punzón para marcar los puntos hechos en el **Paso 5** en la preparación para la perforación. Use **cuidadosamente** el taladro equipado con una broca n.º 16 (.177 in / 4.5 mm) y el collarín de tope para perforar un orificio de 1/8 in (3 mm) en el capó. Después de perforar, aplique el agente anticorrosivo en el orificio. Repita la operación con los orificios restantes.

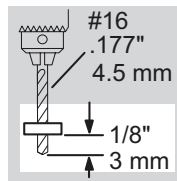
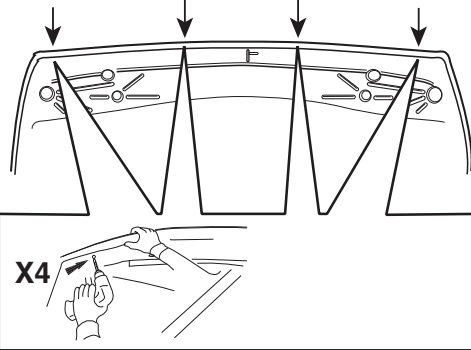

PRECAUCIÓN: NO PERFORE EL CAPO HASTA TRASPASAR EL LADO OPUESTO.

5



Vuelva a ubicar la cubierta del capó sobre el borde del capó, alineando los orificios de la cubierta del capó con los orificios perforados en el **Paso 6**. Inserte un tornillo a través de cada orificio y asegure la cubierta del capó en el capó.

NOTA: NO AJUSTE DEMASIADO.

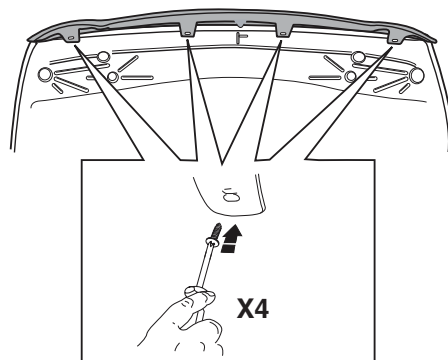
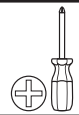

PRECAUCIÓN: NO PRESIONE EL TORNILLO HASTA TRASPASAR EL LADO OPUESTO DEL CAPO.

6

Pasos de instalación

NOTA: El uso real puede variar levemente de ilustraciones.

Alcohol Pad

Cierre el capó y utilice un paño con alcohol para limpiar los puntos en la superficie del capó indicada.

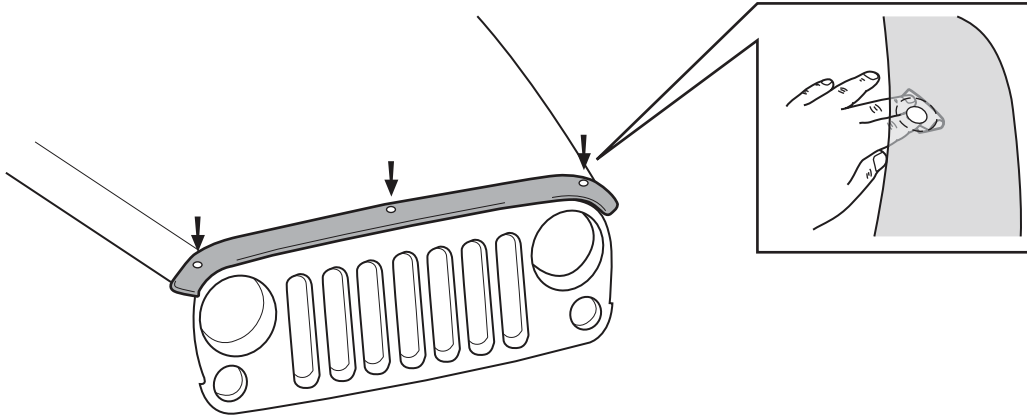

7



Retire la cubierta de la cinta adhesiva que se encuentra en la parte posterior inferior de los tres (3) toques de goma y aplique en los puntos que ha limpiado en el **Paso 8**.

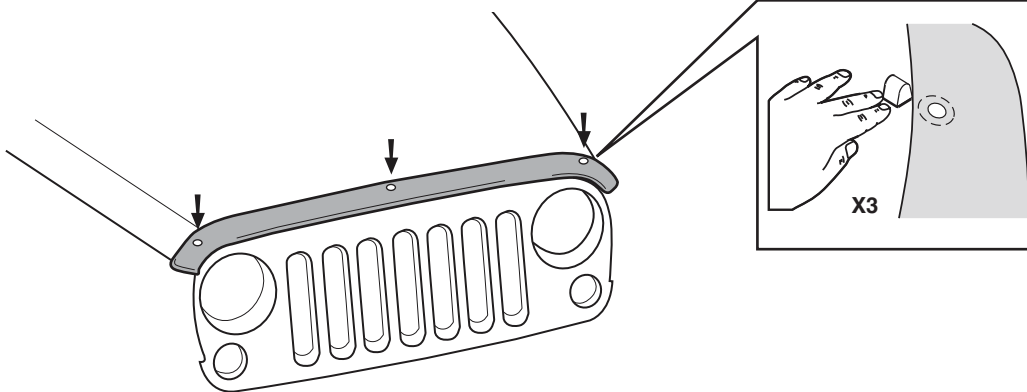

8

Cuidado y limpieza

- Limpie solamente con agua jabonosa tibia y seque con un paño limpio.

Felicidades

Usted ha adquirido uno de los tantos productos de calidad de marca Lund[®] que ofrece Lund International, Inc. Nos enorgullecen mucho nuestros productos y deseamos que disfrute años de satisfacción por su inversión. Nos hemos esforzado mucho para asegurarnos de que su producto sea de gran calidad en cuanto a ajuste, durabilidad, acabado y facilidad de instalación.

LUND[®]

Lund International

800-241-7219 • Visite nuestro sitio Web: lundinternational.com

© 2012 Lund International, Inc. Todos los derechos reservados.

Lund[®] y el logo de Lund[®] son marcas registradas de Lund International, Inc.

