

# INSTALLATION INSTRUCTIONS AND PARTS LIST

MODEL 415114, GRIP STEPS (BOARDS ONLY)

UNIVERSAL APPLICATIONS

1. Read instructions completely and check to make sure that all required parts (listed on the service parts list) are on hand before starting the installation.
2. Follow the instructions included with the specific bracket package to mount the brackets to your vehicle.
3. Step assembly:
  - 3.1 This Board can be modified from its original length to fit many applications. Simply determine how long you will need the board, and cut to that length using a saber saw, chop saw, or hack saw. Use flat black paint to touch up the ends that were cut.
  - 3.2 Before attaching the grip steps to the brackets, slide the appropriate number of support braces (item #2) into the channel of the step (item #1).
  - 3.3 Slide the end cap (item #3) over the front and rear of each step. Using the supplied #8 x 1/2" self drilling tek screw (item #8), screw the end cap to the bottom of the step.
4. Attaching the step to the mounting bracket:
  - 4.1 Set the step on the mounting brackets, and slide each support brace over the top of each mounting bracket. Attach the flat spacer plate (item #4) to the bottom of the step, between the support brace, and the top of the mounting bracket.
  - 4.2 Using the supplied 5/16-18 x 1" carriage bolt, washer, and flange nuts, (item #5, 6, 7), attach the step assembly, flat spacer plate and mounting bracket. **(NOTE: Some of the flange nuts are supplied in the specific bracket package, not the step package.)**
  - 4.3 Set the step plate in the correct position and tighten all fasteners.  
Torque all fasteners to 19 LB FT.

## SERVICE PARTS LIST

ITEM	PART NO.	QTY	DESCRIPTION
1	551888	2	EXTRUSION-AL,97.87,GRIP STEP,BLK,415098
1	551889	2	EXTRUSION-AL,101.25,GRIP STEP,BLK,415102
1	551388	2	EXTRUSION-AL,113.62,GRIP STEP,BLK,415114
2	551296	10	SUPPORT BRACE, UPPER, GALV.
3	551394	4	CAP-END,GRIP STEP, BLACK, PLASTIC
4	551298	14	SPACER PLATE, LOWER, BLACK
5	108683	20	BOLT-CRG,5/16-18 X 1.0", SST
6	101369	20	WASHER-FLAT,5/16,SST
7	102680	20	NUT-SERR FLG,HX,SST,WX,5/16-18
8	107958	8	SCR-TEK #8-18 X 1/2",SST,BLK



1200 E. Birch St.

Brandon, SD 57005

REV C 01APR12

REV B 03DEC10

REV A 10JUL09

551391 SHEET 1 OF 2 01JUN09

SERVICE PARTS LIST

MODEL NO. - 415098  
 415102  
 415114

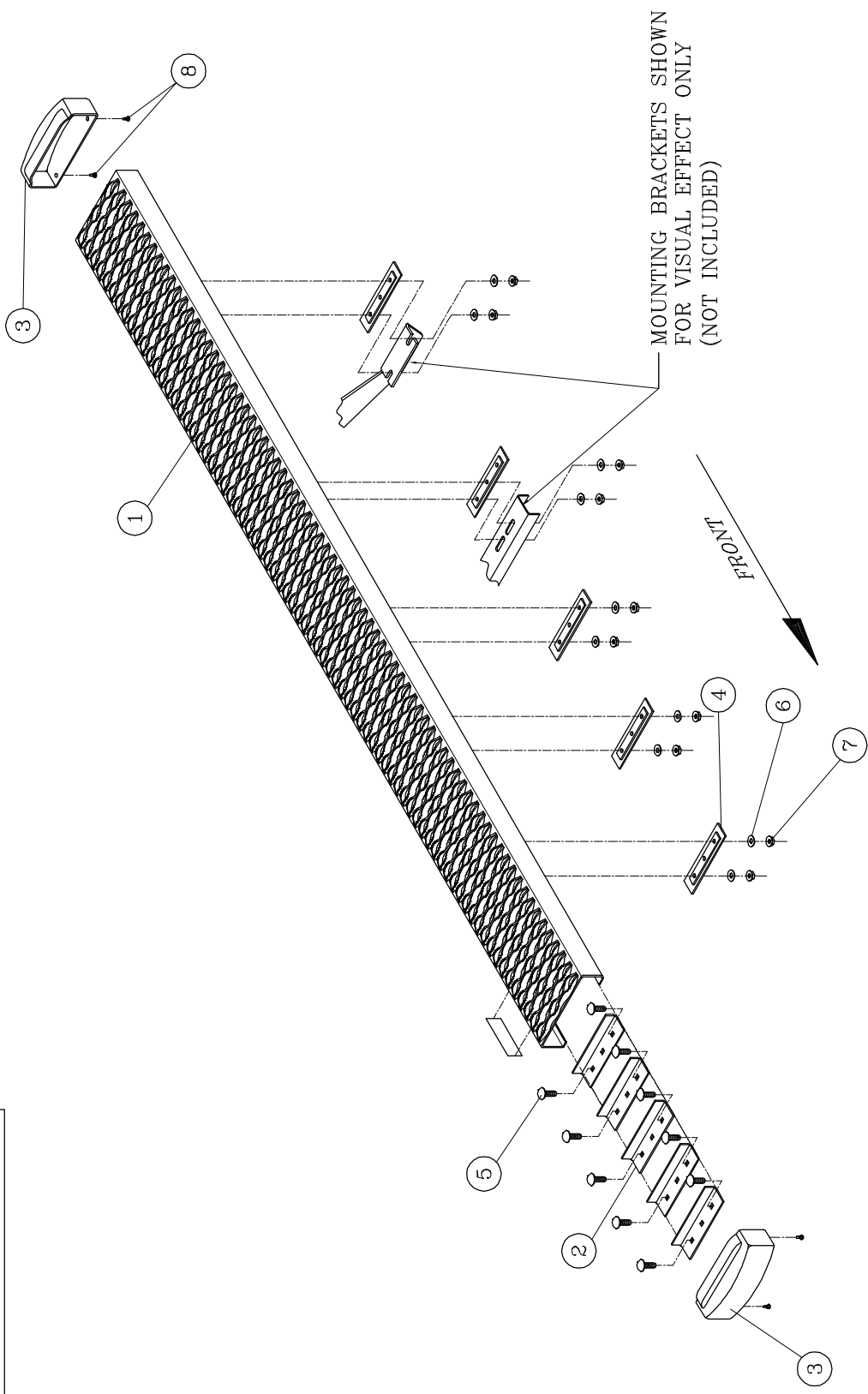

## INSTALLATION INSTRUCTIONS AND PARTS LIST

APPLICATION: MODEL 401729/401728 W2W GRIP STEP BRACKETS ON:  
2017+ FORD SUPER DUTY PICKUPS



### NO DRILL APPLICATION

1. READ INSTRUCTIONS COMPLETELY AND CHECK TO MAKE SURE THAT ALL REQUIRED PARTS (LISTED ON SERVICE PARTS LIST) ARE ON HAND BEFORE STARTING THE INSTALLATION.
2. ON THE LEFT SIDE OF THE VEHICLE INSTALL TWO 1.5" ISOLATOR WASHERS (ITEM #3), THE STEP MOUNTING BRACKET (ITEM #2) AND TWO M8-1.25 FLANGE NUTS (ITEM #4) OVER THE FACTORY PROVIDED STUDS ON THE INSIDE OF THE ROCKER PANEL AS SHOWN.
3. REPEAT STEP 2 FOR THE REAR BRACKET.
4. CHECK THAT THE FRONT AND REAR BRACKETS ARE LEVEL AND TIGHTEN ALL FLANGE NUTS.

**NOTE: IF INSTALLING ON A REGULAR CAB PICKUP SKIP TO STEP #10.**

5. REMOVE THE CENTER BODY MOUNT BOLT AND INSTALL THE CENTER INBOARD MOUNTING BRACKET (ITEM #10) AS SHOWN IN FIGURE 1.
6. USING THREE 3/8"-18 X 1.0" HEX BOLTS (ITEM #5) THREE 3/8" FLAT WASHERS (ITEM #6) AND THREE 3/8"-18 FLANGE NUTS (ITEM #7) ATTACH THE OUTBOARD BRACKET (ITEM #11) TO THE INBOARD BRACKET (ITEM #10). ADJUST THE HEIGHT TO MATCH YOUR STEP BOARD AND TIGHTEN BOLTS.
7. ASSEMBLE THE LOAD REACTION STUDS AND HARDWARE (ITEMS #6-9) AS FOLLOWS.
  - 7.1. ON THE SHORT THREADED END OF THE LOAD REACTION STUD (ITEM #9), INSTALL A 3/8" FLANGE NUT (ITEM #7) BACKWARDS ONTO THE BOTTOM OF THE THREAD. THEN INSTALL A 3/8" FLAT WASHER (ITEM #6) AND RUBBER CUSHION WASHER (ITEM #8) TIGHT UP AGAINST THE FLANGE NUT. (THE END OF THE STUD MUST BE RECESSED IN THE RUBBER WASHER APPROX. 3/16")
  - 7.2. ON THE LONG THREADED END OF THE STUD, INSTALL A 3/8" FLANGE NUT (ITEM #7) BACKWARDS TO NEAR THE BOTTOM OF THE THREADS.
8. CHECK THAT THE CENTER BRACKET IS PERPENDICULAR TO THE BODY OF THE VEHICLE AND TIGHTEN THE BODY MOUNT BOLT PER THE MANUFACTURES SPECIFICATIONS.
9. INSTALL THE LOAD REACTION STUD INTO THE CENTER INBOARD BRACKET (ITEM #10) AS SHOWN IN FIGURE 1 AND ADJUST THE INBOARD NUT SO THAT THE RUBBER CUSHION WASHER IS SNUG UP AGAINST THE FRAME OF THE VEHICLE. INSTALL A 3/8" FLANGE NUT (ITEM #7) ON THE OUTBOARD SIDE OF THE STUD AND TIGHTEN TO 19 LB-FT.
10. LOOSEN THE NUT AND BOLT ON THE SPRING SHACKLE JUST ENOUGH TO SLIP THE REAR INBOARD BRACKET (ITEM #12) BEHIND THE NUT AS SHOWN IN FIG 2.. NOTE: ON THE PASSENGER SIDE THE NUT WILL HAVE TO BE LOOSENED, AND THE BOLT SLID OUTWARD IN ORDER TO INSTALL THE MOUNTING BRACKET. **DO NOT REMOVE THE BOLT COMPLETELY AS THIS COULD RESULT IN INJURY.** ADJUST THE BRACKET SO THAT IT IS VERTICAL AND TIGHTEN TO 80 LB-FT.



REV B 18JAN17  
REV A 30DEC16  
553107 SHEET 1 OF 3 06OCT16

11. USING TWO 5/16-18 X 1" BOLTS (ITEM #16) TWO 5/16 FLAT WASHER (ITEM #15) AND TWO 5/16-18 FLANGE NUTS (ITEM #17) INSTALL THE OUTBOARD BRACKET (ITEM #14) AS SHOWN IN FIGURE 2.  
**NOTE: LEAVE THIS BRACKET LOOSE AT THIS TIME.**
12. ATTACH THE STEP BOARD TO THE MOUNTING BRACKETS AS DESCRIBED IN THE INSTRUCTION SHEET INCLUDED WITH YOUR STEP BOARD ASSEMBLY.
13. ADJUST THE REAR OUTBOARD BRACKET FOR YOUR STEP ASSEMBLY AND TIGHTEN THE BOLTS SECURING THE OUTBOARD BRACKET TO THE INBOARD BRACKET.
14. REPEAT STEPS 2 – 13 FOR THE RIGHT SIDE OF THE VEHICLE.

### SERVICE PARTS LIST

ITEM	PART NO.	QTY	DESCRIPTION
1		1	STEP ASSY, GRIP STEP
2	552845	4	BRACKET-MTG, GRIP STEP, 401729
2	553168	4	BRACKET-MTG, GRIP STEP, 401728
3	108442	8	WASHER – NYLON, .36" X 1.5" X .032" BLACK
4	105859	8	NUT- FLANGE, M8-1.25, ZP
5	100040	6	BOLT-HEX HD, 3/8"-16 X 1.00", ZP
6	100062	8	WASHER-FLAT, 3/8", ZP
7	106995	12	NUT-FLANGE, 3/8"-16, ZP
8	102592	2	WASHER-RUBBER, .354 X 1.0 X .75
9	104673	2	STUD-DBL END, 3/8"-16 X 5"
10	552843	2	BRKT-MTG, CTR, INBOARD, 401729
10	553169	2	BRKT-MTG, CTR, INBOARD, 401728
11	552844	2	BRKT-MTG, CTR, OUTBOARD, 401529
12	553102	1	BRKT-MTG, REAR, W2W, INBOARD, LH, 401729
12	553170	1	BRKT-MTG, REAR, W2W, INBOARD, LH, 401728
13	553103	1	BRKT-MTG, REAR, W2W, INBOARD, RH, 401729
13	553171	1	BRKT-MTG, REAR, W2W, INBOARD, RH, 401728
14	552125	2	BRKT-MTG, REAR, W2W, OUTBOARD,
15	106998	4	WASHER-FLAT, .375X.875X.083, BZP
16	106997	4	SCR-HEX, 5/16-18 X 1.0", BZP
17	106996	4	NUT-FLANGE, 5/16-18, BZP



SERVICE PARTS LIST

MODEL NO. - 401729  
401728

**FORD SUPER DUTY  
WZV GRIP STEPS**

FIG 3

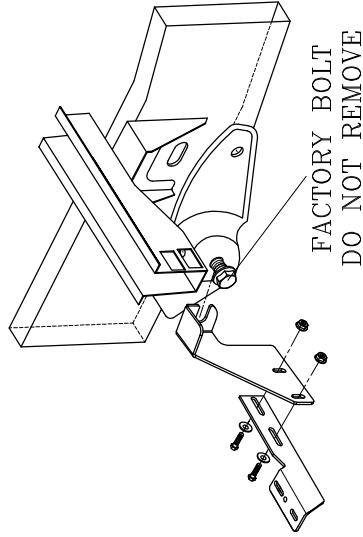

REAR BRACKET ASSEMBLY -  
RH (PASSENGER SIDE) -

FIG 2

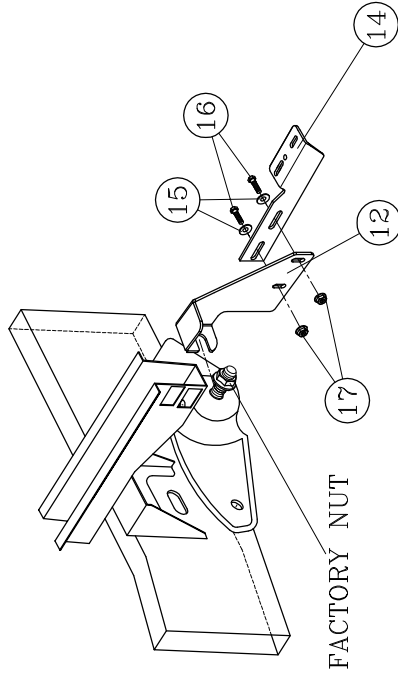

FACTORY NUT  
REAR BRACKET ASSEMBLY -  
LH (DRIVER SIDE) -

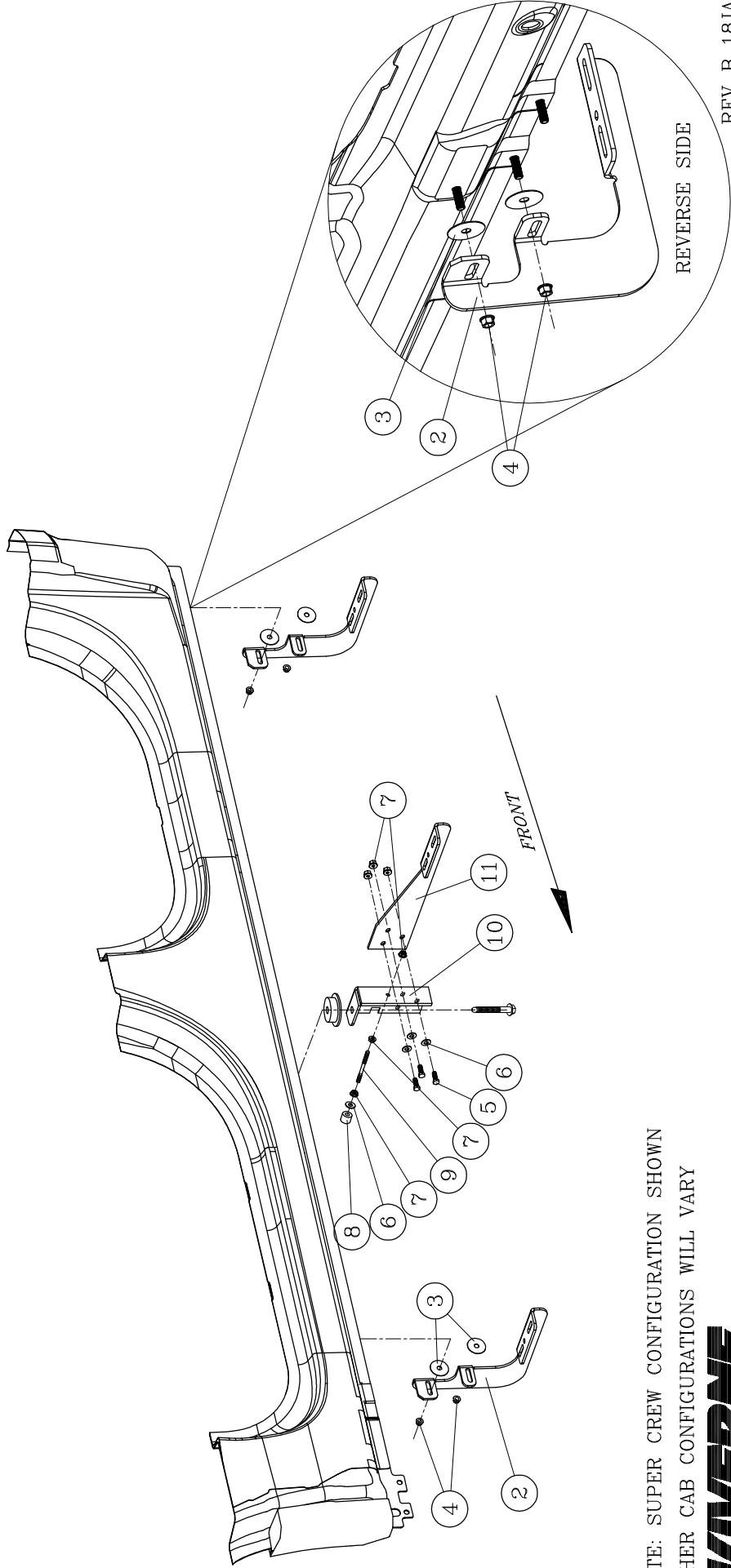

REV B 18JAN17  
REV A 30DEC16  
553107 SHEET 3 OF 3 06OCT16

FIGURE 1 -  
LEFT (DRIVERS) SIDE SHOWN -

NOTE: SUPER CREW CONFIGURATION SHOWN  
OTHER CAB CONFIGURATIONS WILL VARY

