

## INSTALLATION INSTRUCTIONS AND PARTS LIST

**APPL: 46/450719 SERIES W2W STAINLESS STEEL & BLACK NERF BARS ON:  
2007 AND NEWER CHEVROLET/GMC CREW CAB PICKUPS 6.5**



1. READ INSTRUCTIONS COMPLETELY AND CHECK TO MAKE SURE THAT ALL REQUIRED PARTS (LISTED ON SERVICE PARTS LIST) ARE ON HAND BEFORE STARTING THE INSTALLATION.
2. NERF BAR TUBE/MOUNTING BRACKET ASSEMBLIES (ITEM #1 THRU #9) ARE PRE-ASSEMBLED.
  - 2.1. THE FRONT & REAR MOUNTING BRACKETS ON THESE ASSEMBLIES ARE ROTATED TOWARD THE CENTER (INBOARD OF LEGS) FOR SHIPPING PURPOSES. THESE BRACKETS MUST BE ROTATED TO THE VERTICAL POSITION AND THE ½” BOLTS MUST BE TORQUED TO 65 LB. FT.

**NOTE:**

**DUE TO EXCESSIVE THREAD LOCKER IN THE BODY MOUNT BOLT AREA ON THE 2010+ GM SILVERADO/SIERRA, USE CAUTION WHEN REMOVING THE BODY MOUNT BOLTS TO REDUCE THE RISK OF CAUSING DAMAGE TO THE THREADED INSERTS INSIDE THE VEHICLE.**

- 3 REMOVE THE FOUR (4) APPLICABLE FACTORY BODY MOUNT BOLTS FROM THE VEHICLE.
  - 3.1 THESE FOUR (4) BOLTS ARE REUSED IN THIS INSTALLATION.
  - 3.2 THE BODY MOUNT STEEL WASHER PLATES WITH RUBBER CUSHIONS ARE REUSED BETWEEN THE BODY MOUNT AND THE NERF BAR MOUNTING BRACKET.
4. POSITION THE NERF BAR ASSEMBLY UP UNDER THE VEHICLE AND ATTACH THE FRONT AND REAR BRACKETS TO THE BODY MOUNTS WITH FACTORY BODY MOUNT BOLTS AS SHOWN.
5. TORQUE ALL BODY MOUNT BOLTS TO 65 LB. FT

### SERVICE PARTS LIST

ITEM	PART NO.	QTY	DESCRIPTION
1	551135	1	NERF BAR WLDMT-GM,W2W,LH,CO117SST
2	551136	1	NERF BAR WLDMT-GM,W2W,RH,CO117SST
1	551127	1	NERF BAR WLDMT-GM,W2W,LH,BLK,CO117TB
2	551128	1	NERF BAR WLDMT-GM,W2W,RH,BLK,CO117TB
3	551111	2	SPACER-TUBE,C9917SST
3	551116	2	SPACER-TUBE,C9917STB
4	551112	2	TRIM-SPACER TUBE
5	103950	6	PAD-STEP,NB,BLK,20” LG
6	102500	2	INSR-FNSH,RIBBED,14-18 GA
7	550130	2	BRKT-MTG,FRONT
8	549077	2	BRKT-MTG,REAR
9	104249	4	BOLT-HEX HD CAP,SERR FLG,1/2-13 X 2.00,ZP
10	100118	4	WASHER-FLAT,.562 ID X 1.38 OD X .109 T,ZP

SERVICE PARTS LIST

MODEL NO. -460719  
 MODEL NO. -450719

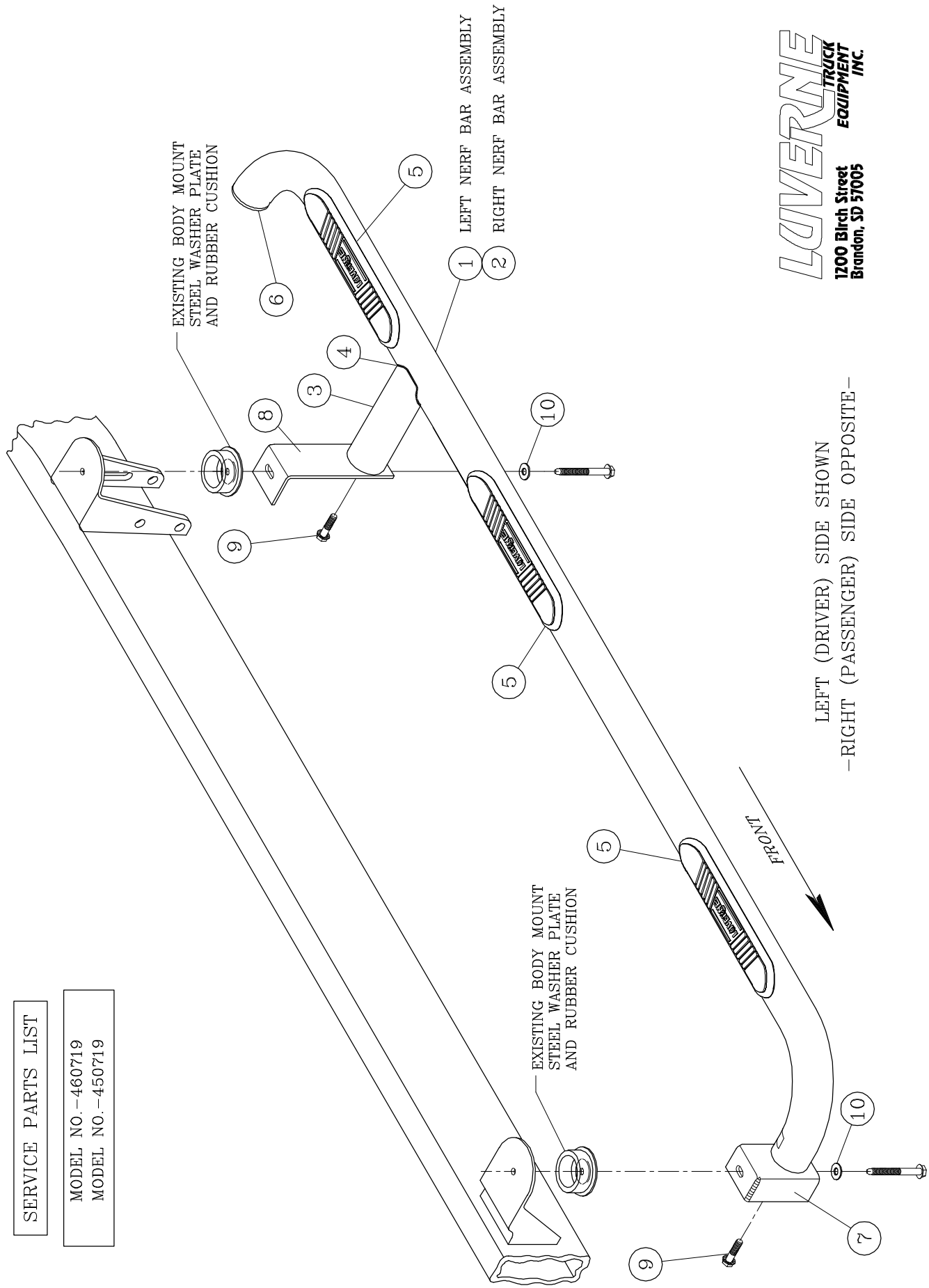

LEFT (DRIVER) SIDE SHOWN  
 -RIGHT (PASSENGER) SIDE OPPOSITE-

**LOVERONE** TRUCK EQUIPMENT INC.  
 1200 Birch Street  
 Brandon, SD 57005

REV B 21MAY14  
 REV A 03SEPT10  
 551304 SHEET 2 08FEB07