

INSTALLATION INSTRUCTIONS AND PARTS LIST

APPL: MODEL 450429 BLACK AND MODEL 460429 STAINLESS STEEL NERF BARS ON:
2004 AND NEWER FORD F150 SUPER CREW PICKUPS (5-1/2 FOOT BOX)



NO DRILL INSTALLATION

1. READ INSTRUCTIONS COMPLETELY AND CHECK TO MAKE SURE THAT ALL REQUIRED PARTS (LISTED ON SERVICE PARTS LIST) ARE ON HAND BEFORE STARTING THE INSTALLATION.
2. NERF BARS (ITEMS #1 & #2) AND MOUNTING BRACKETS (ITEMS #3, #4, #5 & #6) ARE PRE-ASSEMBLED TO MATCH THE EXISTING MOUNTING HOLE LOCATIONS IN THE VEHICLE. IF ANY ADDITIONAL ADJUSTMENT SHOULD BE REQUIRED, THIS CAN BE ACCOMPLISHED BY LOOSENING THE PRE-TORQUED 1/2 IN. HEX HEAD BOLT THAT RETAINS THE FRONT AND REAR MOUNTING BRACKETS TO THE NERF BAR. IF THE PRE-TORQUE ON THIS 1/2 IN. BOLT IS BROKEN, THE BOLT MUST BE RE-TIGHTENED TO 65 LB. FT
3. EXISTING MOUNTING HOLE PATTERNS ARE LOCATED ON THE INTERIOR WALL AND PINCH WELD OF THE ROCKER PANEL. THESE MOUNTING HOLE PATTERNS MUST BE USED FOR THIS INSTALLATION PER THE FOLLOWING INSTRUCTIONS.
 - 3.1. FACTORY TAPE MAY BE COVERING THE MOUNTING HOLES. IF SO, REMOVE THE TAPE TO INSTALL THE MULTI THREAD U-NUTS. (THIS TAPE MUST BE RE-INSTALLED OVER THE ACCESS HOLES, LEAVING ONLY THE THREADS OF THE U-NUTS UNCOVERED).
 - 3.2. INSTALL 5/16" MULTI THREAD U-NUTS (ITEM #12) IN THE TOP TWO HOLES OF THE FRONT AND REAR INTERIOR WALL MOUNTING HOLE PATTERNS. INSTALL THESE NUTS SO THAT THE THREADS ARE TO THE INSIDE OF THE ROCKER PANEL. (THIS IS DONE BY INSERTING THE THREADED HALF OF THE U-NUT THRU THE ACCESS HOLE, AND SLIDING THE U-NUT TOWARDS THE MOUNTING HOLE UNTIL THE NUT SEATS IN THE HOLE).
4. INSTALL THE NERF BAR ASSEMBLY AS FOLLOWS:
 - 4.1. POSITION THE NERF BAR ASSEMBLY UP TO THE ROCKER PANEL SO THAT THE HOLES IN THE MOUNTING BRACKETS MATCH THE U-NUTS IN THE HOLE PATTERNS DISCUSSED IN INSTRUCTION 3.2. (THE BRACKETS WITH THE OFFSET GO TOWARD THE FRONT OF THE VEHICLE). (FOR THE LEFT HAND FRONT BRACKET, POSITION THE BRAKE CABLE SO THAT IT LIES ON TOP OF THE BRACKET.)
 - 4.2. HANG THE NERF BAR ASSEMBLY ON THE UPPER BOLTS BY INSERTING 5/16" X 1.00" HEX HD SCREWS (ITEM #10) WITH 5/16" FLAT WASHERS (ITEM #13) THROUGH THE HOLES IN THE BRACKET AND ROCKER PANEL AND INTO THE MULTI THREAD U-NUTS INSTALLED PER INSTRUCTION 3.2.
 - 4.3. INSTALL 5/16" X 1.00" HEX HEAD SCREWS (ITEM #10) WITH 5/16" FLAT WASHERS (ITEM #13) UP THROUGH THE HOLES IN THE PINCH WELD AND THE FLANGES OF THE BRACKETS AND INSTALL 5/16" FLAT WASHERS (ITEM #13) AND 5/16"-18 SERRATED FLANGE NUTS (ITEM #11).
 - 4.4. TIGHTEN ALL 5/16" MOUNTING FASTENERS TO 19 LB. FT.
5. IF DESIRED, INSTALL THE 4" X 6" NON-SKID STEP PAD (ITEM #16) NEAR THE REAR END OF THE NERF BAR AS FOLLOWS: (NOTE: THE NERF BAR & STEP PAD MIN. APPL. TEMP. IS 40 DEG. F).
 - 5.1. CLEAN THE NERF BAR IN THE AREA WHERE THE STEP PAD IS TO BE LOCATED.
 - 5.2. PEEL THE PAPER BACKING OFF THE PAD AND INSTALL THE PAD ON THE BAR AS DESIRED.

INSTALLATION INSTRUCTIONS AND PARTS LIST

APPL: MODEL 450429 BLACK AND MODEL 460429 STAINLESS STEEL NERF BARS ON:
2004 AND NEWER FORD F150 SUPER CREW PICKUPS (5-1/2 FOOT BOX)

SERVICE PARTS LIST

ITEM	PART NO.	QTY	DESCRIPTION
1	551243	1	NB WLDMT-LH, 460429 (SST)
2	551244	1	NB WLDMT-RH, 460429 (SST)
1	551241	1	NB WLDMT-LH, 450429 (BLACK)
2	551242	1	NB WLDMT-RH, 450429 (BLACK)
3	551205	1	MOUNTING BRKT-FRONT, LH
4	551207	1	MOUNTING BRKT-FRONT, RH
5	551209	1	MOUNTING BRKT-REAR,LH
6	551211	1	MOUNTING BRKT-REAR,RH
7	551233	2	W2W SPACER TUBE- SST,04 F-150
7	551235	2	W2W SPACER TUBE- BLACK,04 F-150
8	103950	4	PAD-STEP,NERF BAR,BLK,20"
9	104249	4	SCREW-HHC, SERR FLNG, 1/2-13 X 2.00",ZP
10	100647	16	SCREW-HHC,5/16-18 X 1.00",ZP
11	100178	8	NUT-SERR FLANGE, 5/16"-18
12	104264	8	NUT-U MULTI THD, 5/16"-18 UNC
13	100034	24	WASHER-FLAT,5/16",ZP
14	551112	2	TRIM-W2W SPACER TUBE
15	102500	2	INSERT-FINISH, RIBBED, 14-18 GA
16	106299	2	PAD-TAPE,4.00 X 6.00

SERVICE PARTS LIST

MODEL NO. - 450429/460429

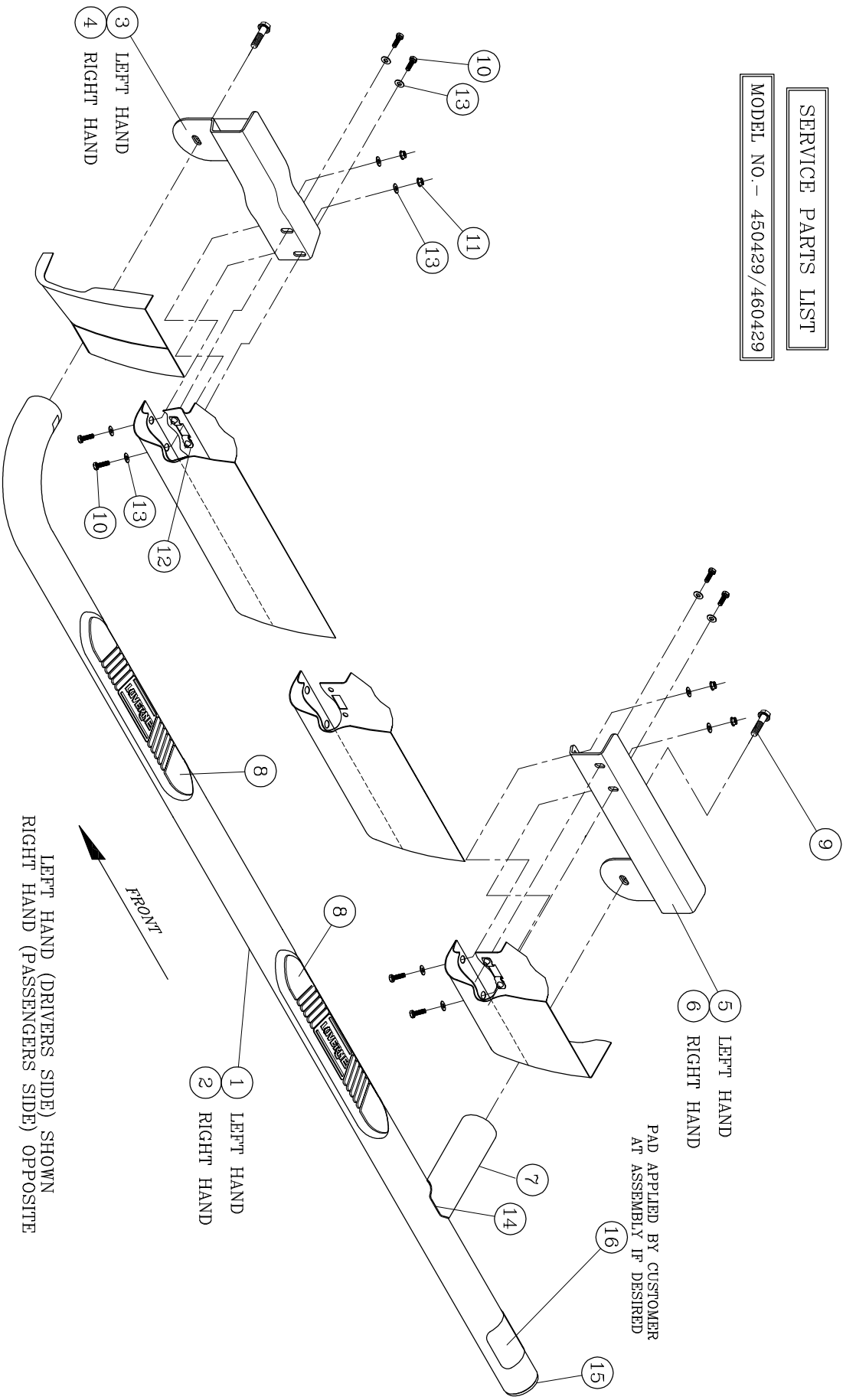

5 LEFT HAND
6 RIGHT HAND

PAD APPLIED BY CUSTOMER
AT ASSEMBLY IF DESIRED

1 LEFT HAND
2 RIGHT HAND

LEFT HAND (DRIVERS SIDE) SHOWN
RIGHT HAND (PASSENGERS SIDE) OPPOSITE

FRONT