

INSTALLATION INSTRUCTIONS AND PARTS LIST

STAINLESS STEEL W2W NERF BAR:

461437 2009 AND NEWER DODGE RAM **QUAD** CAB 6.7 BOX

461439 2009 AND NEWER DODGE RAM **CREW** CAB 5.5 BOX



1. READ INSTRUCTIONS COMPLETELY AND CHECK TO MAKE SURE THAT ALL REQUIRED PARTS (LISTED ON SERVICE PARTS LIST) ARE ON HAND BEFORE STARTING THE INSTALLATION.
2. NERF BAR TUBE AND MOUNTING BRACKET ASSEMBLIES ARE PRE-ASSEMBLED.
 - 2.1. THE FRONT AND REAR MOUNTING BRACKETS ON THESE ASSEMBLIES ARE ROTATED INBOARD OF THE LEGS FOR SHIPPING PURPOSES. THESE BRACKETS MUST BE ROTATED TO THE VERTICAL POSITION. DO NOT TIGHTEN THESE BOLTS AT THIS TIME. THE REAR BRACKET WILL REQUIRE SOME VERTICAL ADJUSTMENT.
3. ASSEMBLE THE DOUBLE ENDED STUD & FASTENERS TO THE FRONT & REAR BRACES AS FOLLOWS,
 - 3.1. INSTALL 3/8" SERRATED FLANGE NUTS (ITEM #14) **BACKWARDS**, TO THE END OF THE THREAD, ON EACH END OF THE DOUBLE ENDED STUD (ITEM #13).
 - 3.2. ON THE SHORT THREADED END OF THE STUD, INSTALL A 3/8" FLAT WASHER (ITEM #15). THEN, PUSH THE 3/4" THICK RUBBER WASHER (ITEM #16) & FLAT WASHER TIGHT UP AGAINST THE SERRATED FLANGE NUT. (THE END OF THE DOUBLE ENDED STUD SHOULD BE RECESSED BACK IN THE HOLE OF THE RUBBER WASHER APPROXIMATELY 3/16").
 - 3.3. INSTALL THE LONG THREADED END OF THE STUD ASSEMBLY THRU THE HOLE IN THE MOUNTING BRACKET (JUST ABOVE THE NERF BAR TUBE) AND INSTALL A 3/8" SERRATED FLANGE NUT AS SHOWN. (FINGER TIGHT ONLY).
4. REMOVE THE FOUR (4) APPLICABLE M12-1.75 BODY MOUNT BOLTS FROM THE VEHICLE. **(THE FRONT BOLTS AND WASHERS ARE NOT REUSED).**
5. POSITION THE NERF BAR ASSEMBLY UP UNDER THE BODY MOUNT METAL BUSHING:
 - 5.1. ON THE FRONT BODY MOUNTS, INSTALL M12-1.75 X 110mm (APPROX. 4-3/8" LONG) HEX HEAD BOLTS (ITEM #12), 1/2" LOCK WASHERS (ITEM #10) AND 1/2" FLAT WASHERS (ITEM #11) UP THRU THE HOLE IN THE NERF BAR MOUNTING BRACKET AND THE BODY MOUNTING BUSHING AS SHOWN.
 - 5.2. **2013+-** ON THE REAR BODY MOUNT, IF THERE IS A CAST IRON DAMPENER, PLEASE REMOVE (THIS IS NOT REUSED). PLACE THE FACTORY BODY MOUNT BOLT AND WASHER THROUGH THE NERF BAR BRACKET AND THE BODY MOUNTING BUSHING AS SHOWN IN **FIG.1 OR FIG 2.**
 - 5.3. **2009 TO 2012-** ON THE REAR BODY MOUNT INSTALL THE FACTORY BOLT AND WASHER THRU THE HOLE IN THE NERF BAR MOUNTING BRACKET AND BODY MOUNT BUSHING AS SHOWN IN **FIG. 3 OR FIG 4.**
 - 5.4. TORQUE ALL M12-1.75 BODY MOUNTING BOLTS TO 45 LB. FT.
 - 5.5. ADJUST THE BOLTS THAT MOUNT THE TUBES TO THE BRACKETS AND MAKE SURE YOU HAVE EQUAL HEIGHT FROM THE FRONT TO THE REAR BRACKET. TORQUE THE 1/2" BOLTS TO 65 LB. FT.
 - 5.6. POSITION THE STUD ASSEMBLIES SO THAT THE RUBBER WASHER IS SNUG UP AGAINST THE FRAME. TIGHTEN THE 3/8" SERRATED FLANGE NUTS ON EITHER SIDE OF THE REAR BRACKET TO LOCK THE STUD ASSEMBLY IN POSITION.



(A LUVERNE Company)

1200 E. Birch St.

Brandon, SD 57005

551499 SHEET 1 OF 6 18OCT13

INSTALLATION INSTRUCTIONS AND PARTS LIST

STAINLESS STEEL W2W NERF BAR:

461437 2009 AND NEWER DODGE RAM **QUAD** CAB 6.7 BOX

461439 2009 AND NEWER DODGE RAM **CREW** CAB 5.5 BOX

SERVICE PARTS LIST

ITEM	PART NO.	QTY	DESCRIPTION
1	551138	1	NERF BAR WLDMT- W2W,LH,SST,460937
2	551139	1	NERF BAR WLDMT- W2W,RH,SST,460937
1	551478	1	NERF BAR WLDMT- W2W,LH,SST,460939
2	551479	1	NERF BAR WLDMT- W2W,RH,SST,460939
3	551149	2	SPCR TUBE, 450637
4	551112	2	TRIM, SPCR TUBE
5	551468	2	MOUNTING BRACKET FRONT, LH/RH
6	552280	2	MOUNTING BRACKET REAR, LH/RH
7	104249	4	SCREW-HEX HEAD, SER FLNG,1/2-13 X 2.0, ZP
8	103950	6	PAD-STEP, NB, BLK, 20.00 LG
9	102500	2	INSR-FNSH, RIBBED, 14-18 GA TUBE
10	100121	2	WASHER-LOCK,1/2",ZP
11	100118	2	WASHER-FLAT,1/2",ZP
12	103444	2	BOLT- HEX HD CAP, M12-1.75 X 110mm
13	108448	4	STUD-DOUBLE ENDED,STL,3/8-16 UNC X 6.00",ZP
14	100181	12	NUT-SERRATED FLANGE,HEX,3/8-16 UNC,ZP
15	100062	4	WASHER-FLAT, 3/8", ZP
16	102592	4	WASHER-RUBBER,.354 ID X 1.00 OD X .75 THK
17	106299	2	PAD-TAPE,4.00 X 6.00



1200 E. Birch St.

Brandon, SD 57005

551499 SHEET 2 OF 6 18OCT13

SERVICE PARTS LIST

MODEL NO. - 460937

2013 RAM 1500 QUAD

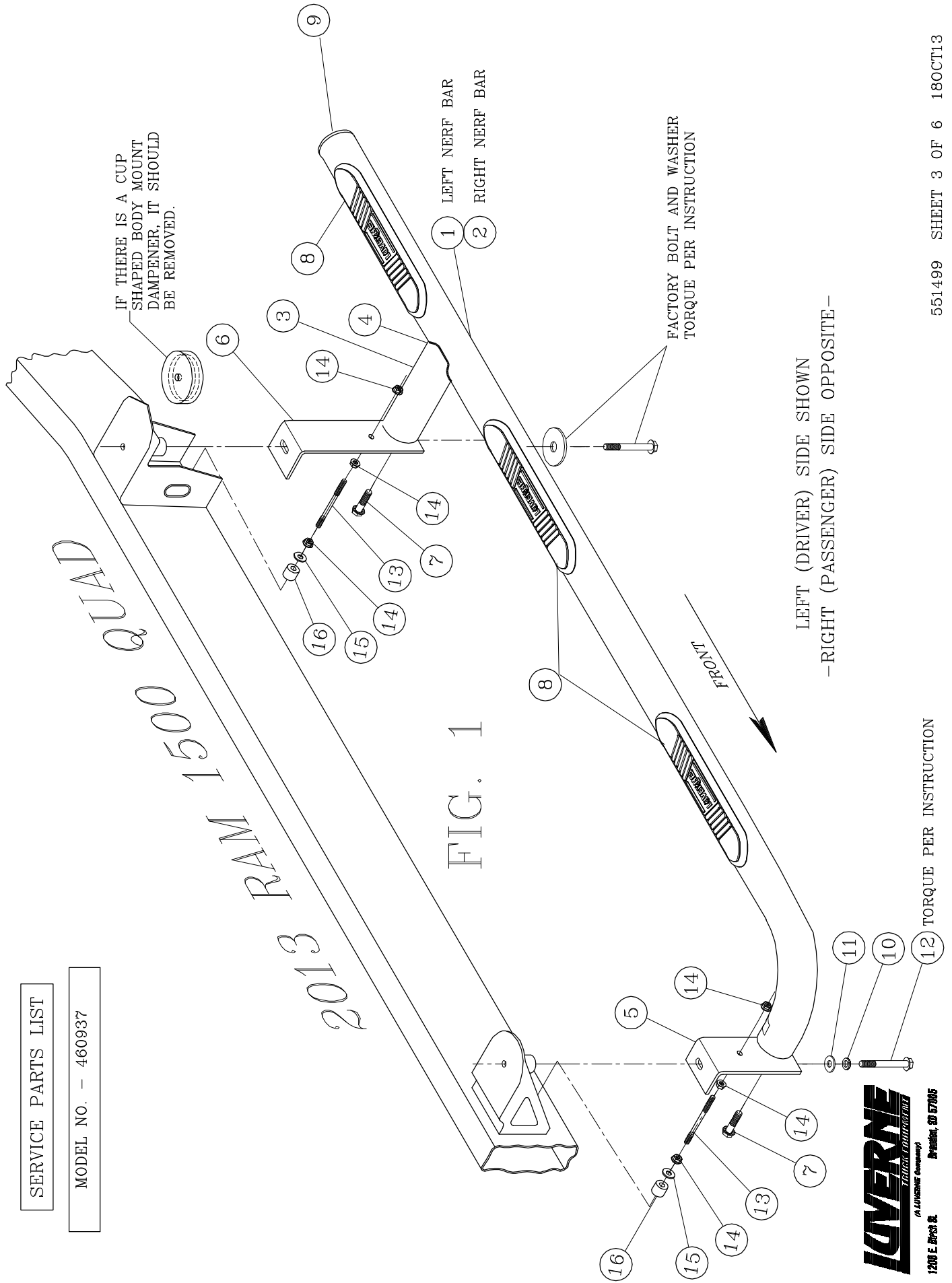

FIG. 1

LEFT (DRIVER) SIDE SHOWN
 -RIGHT (PASSENGER) SIDE OPPOSITE-



1200 E. Birch St.
 Prussia, PA 19005

TORQUE PER INSTRUCTION

SERVICE PARTS LIST

MODEL NO. - 460939

CREW

RAM 1500

2013

FIG. 2

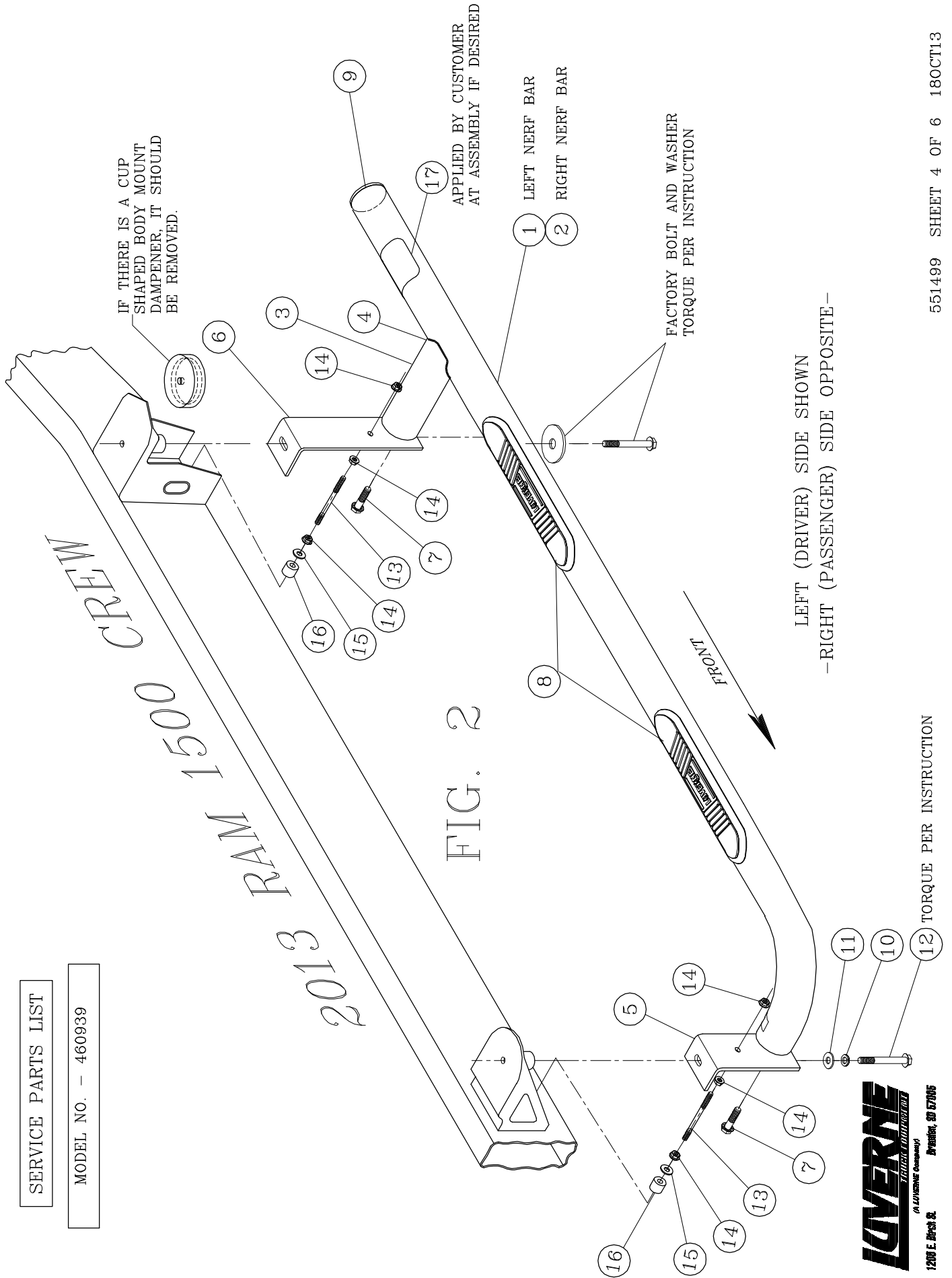

1200 E. Birch St.
Plymouth, MO 67065

TORQUE PER INSTRUCTION

SERVICE PARTS LIST

MODEL NO. - 460937

2009-2012 RAM 1500 QUAD

FIG. 3

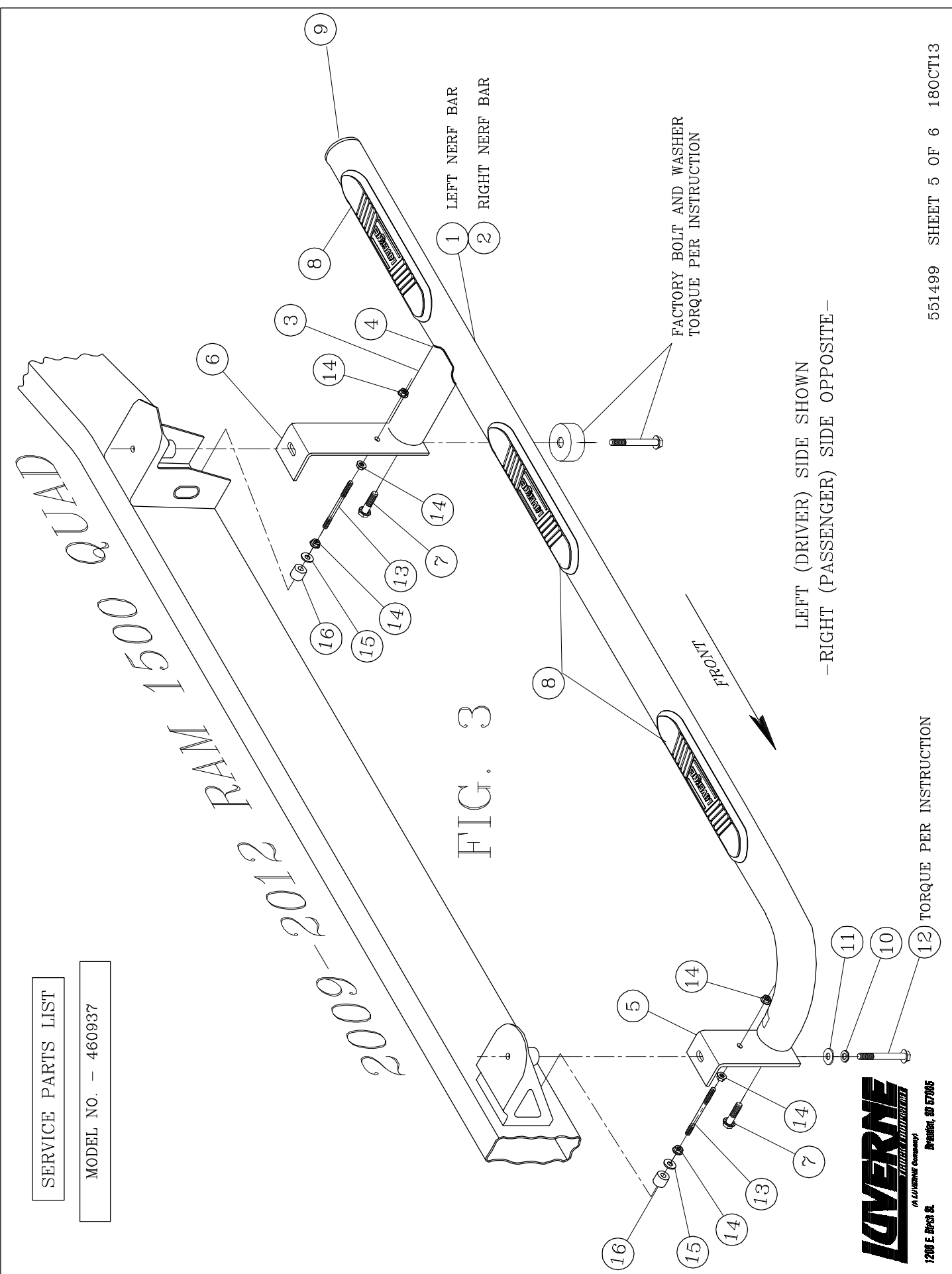

LEFT (DRIVER) SIDE SHOWN
-RIGHT (PASSENGER) SIDE OPPOSITE-



1200 E. Birch St.
Plymouth, MI 48170

TORQUE PER INSTRUCTION

SERVICE PARTS LIST

MODEL NO. - 460939

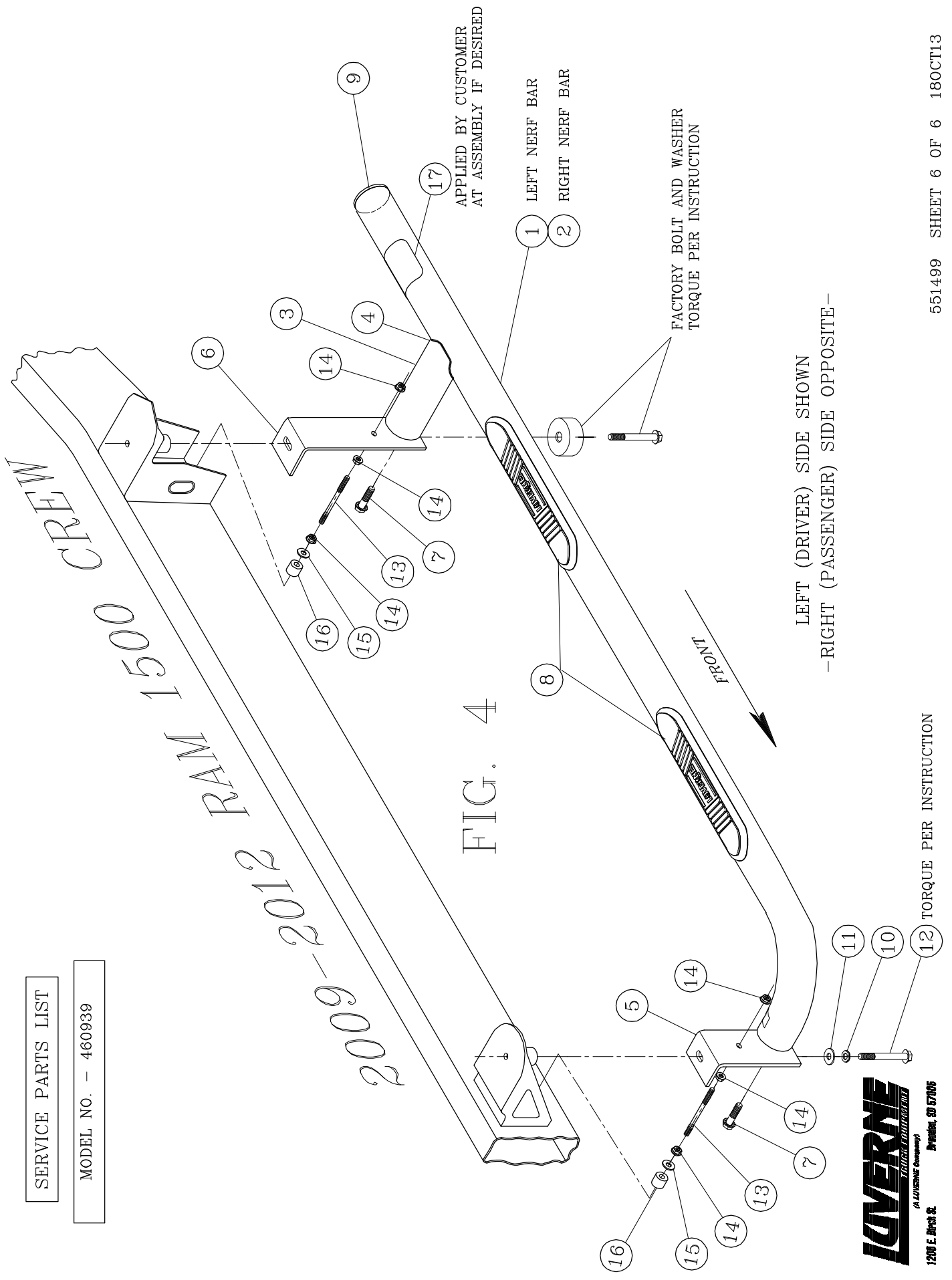

1200 E. Birch St.
Plymouth, MO 67065

TORQUE PER INSTRUCTION