

## INSTALLATION INSTRUCTIONS AND PARTS LIST

VEHICLE APPLICATION: MODEL 500710 (12.00" X 20.00") AND 500713 (12.00" X 23.00")

### FRONT OR REAR MOLDED SPLASH GUARDS

2007 AND NEWER TAHOE AND YUKON SUV'S

1. READ INSTRUCTIONS COMPLETELY AND CHECK TO MAKE SURE THAT ALL REQUIRED PARTS (LISTED ON SERVICE PARTS LIST) ARE ON HAND BEFORE STARTING THE INSTALLATION.
2. PEEL AWAY THE PROTECTIVE VINYL COVERING AND CLEAN THE STAINLESS STEEL SPLASH GUARD INSERTS TO REMOVE ANY RESIDUE. (A GOOD GLASS CLEANER IS SUGGESTED).
3. PREPARE THE SPLASH GUARDS FOR INSTALLATION AS FOLLOWS:
  - 3.1. FORM THE TOP OF THE SPLASH GUARD TO MATCH THE CONTOUR OF THE WHEEL WELL.

#### **MOUNTING 500710 OR 500713 SPLASH GUARDS ON THE FRONT:** (SEE SHEET #2)

4. INSTALL THE SPLASH GUARDS AS FOLLOWS:
  - 4.1. REMOVE TWO FACTORY HEX HEAD SEMS SCREWS (THESE SCREWS ARE REUSED) AND THE BOTTOM INBOARD PLASTIC PUSH IN FASTENER THAT RETAIN THE WHEEL WELL LINER TO THE WHEEL WELL FLANGE.
  - 4.2. POSITION THE SPLASH GUARD AGAINST THE WHEEL WELL FLANGE AND FASTEN AS FOLLOWS. REINSTALL TWO FACTORY HEX HEAD SEMS SCREWS THRU THE TOP AND THIRD HOLE DOWN FROM THE TOP IN THE SPLASH GUARD. INSTALL A 1/4 X 1.00" SOCKET BUTTON HEAD SCREW (ITEM #9), 1/4" FLAT WASHER (ITEM #11) AND 1/4-20 SERR FLANGE NUT (ITEM #10) THRU THE BOTTOM INBOARD HOLE AS SHOWN.
  - 4.3. LOCATE THE SPLASH GUARD IN OR OUT AS DESIRED, LEVEL THE SPLASH GUARD AND TIGHTEN THE FASTENERS.

#### **MOUNTING 500710 OR 500713 SPLASH GUARDS ON THE REAR:** (SEE SHEET #3)

5. INSTALL THE SPLASH GUARDS AS FOLLOWS:
  - 5.1. REMOVE ONE FACTORY HEX HEAD SEMS SCREWS AND ONE PLASTIC PUSH IN FASTENER THAT RETAIN THE WHEEL WELL LINER TO THE WHEEL WELL FLANGE. (THESE FASTENERS ARE NOT REUSED).
  - 5.2. POSITION THE SPLASH GUARD AGAINST THE WHEEL WELL FLANGE AND FASTEN AS FOLLOWS. INSTALL A 30mm (1-3/16" LONG) HEX HEAD SEMS SCREW (ITEM #12) THRU THE SECOND HOLE DOWN FROM THE TOP IN THE SPLASH GUARD. INSTALL A 1/4 X 1.00" SOCKET BUTTON HEAD SCREW (ITEM #9), 1/4" FLAT WASHER (ITEM #11) AND 1/4-20 SERR FLANGE NUT (ITEM #10) THRU THE FORTH HOLE DOWN FROM THE TOP OF THE SPLASH GUARD. LOCATE THE SPLASH GUARD IN OR OUT AS DESIRED, LEVEL THE SPLASH GUARD AND TIGHTEN THE FASTENERS.
  - 5.3. USING THE INBOARD HOLE IN THE SPLASH GUARD AS A PILOT, DRILL A 1/4" DIA HOLE THRU THE WHEEL WELL LINER AND FASTEN WITH A 1/4 X 1.00" SOCKET BUTTON HEAD SCREW (ITEM #9), 1/4" FLAT WASHER (ITEM #11) AND 1/4-20 SERR FLANGE NUT (ITEM #10).



SERVICE PARTS LIST

2007 TAHOE/YUKON  
 MODEL NO. - 500710 & 500713

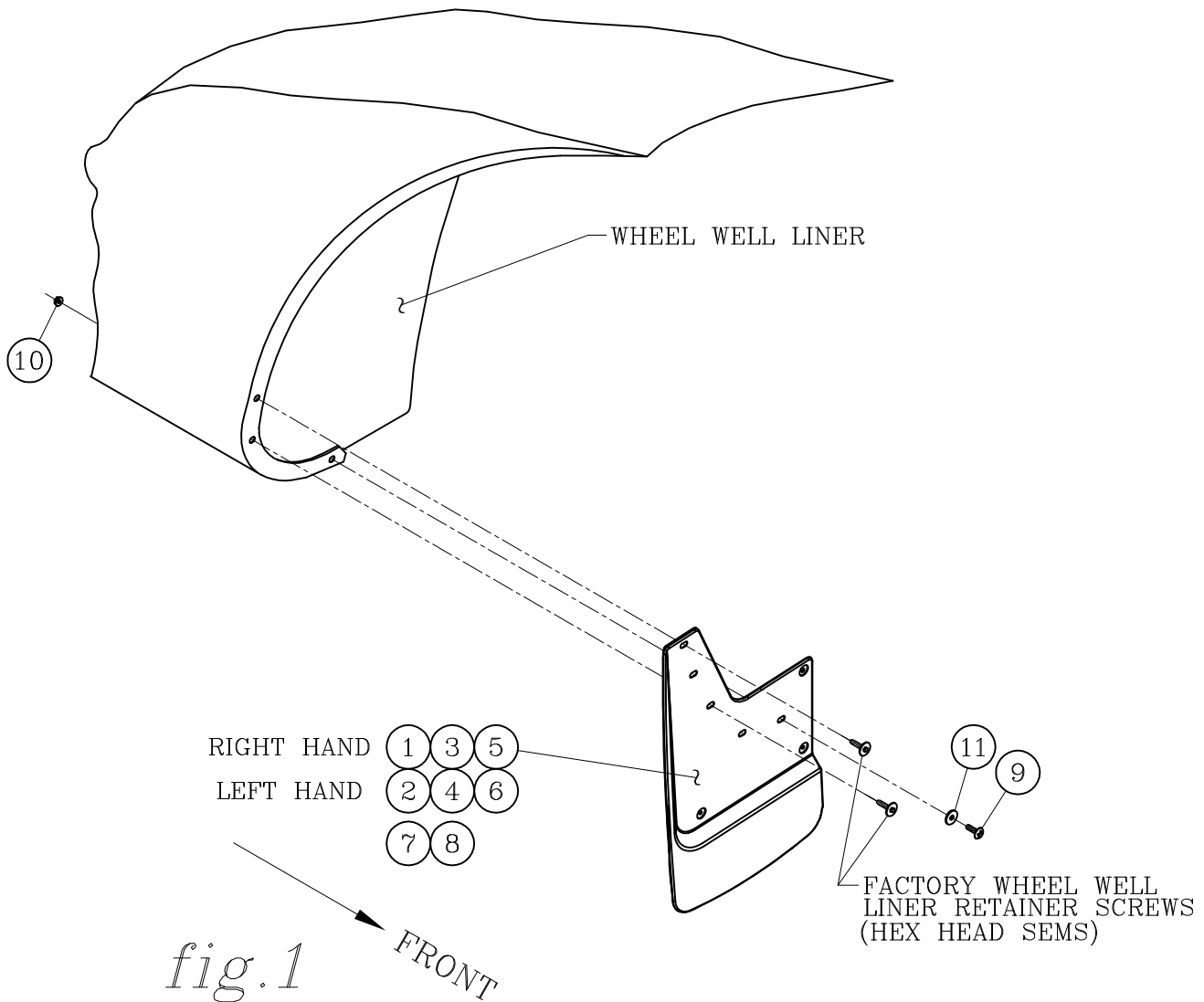

fig.1

FRONT INSTALLATION  
 RIGHT (PASSENGER) SIDE SHOWN

ITEM	PART NO.	QTY	DESCRIPTION
1	550062	1	SPLASH GUARD-MOLDED,12 X 20,TAHOE/YUKON,RH
2	550063	1	SPLASH GUARD-MOLDED,12 X 20,TAHOE/YUKON,LH
3	550064	1	INSERT-SPLASH GUARD, SST, TAHOE/YUKON, RH
4	550065	1	INSERT-SPLASH GUARD, SST, TAHOE/YUKON, LH
5	550066	1	SPLASH GUARD-MOLDED,12 X 23,TAHOE/YUKON,RH
6	550067	1	SPLASH GUARD-MOLDED,12 X 23,TAHOE/YUKON,LH
7	103146	4	RIVET- SST, 3/16 X 3/8
8	105511	4	WASHER- FLAT, SST, .203 X .625 X .062
9	105543	2	SCREW- BTN HD SOC, SST, 1/4-20 X 1.00"
10	102366	2	NUT- HEX, SERR FLG, SST,1/4-20
11	101370	2	WASHER- FLAT, SST, .281 X .625 X .065

SERVICE PARTS LIST

2007 TAHOE/YUKON  
MODEL NO. - 500710 & 500713

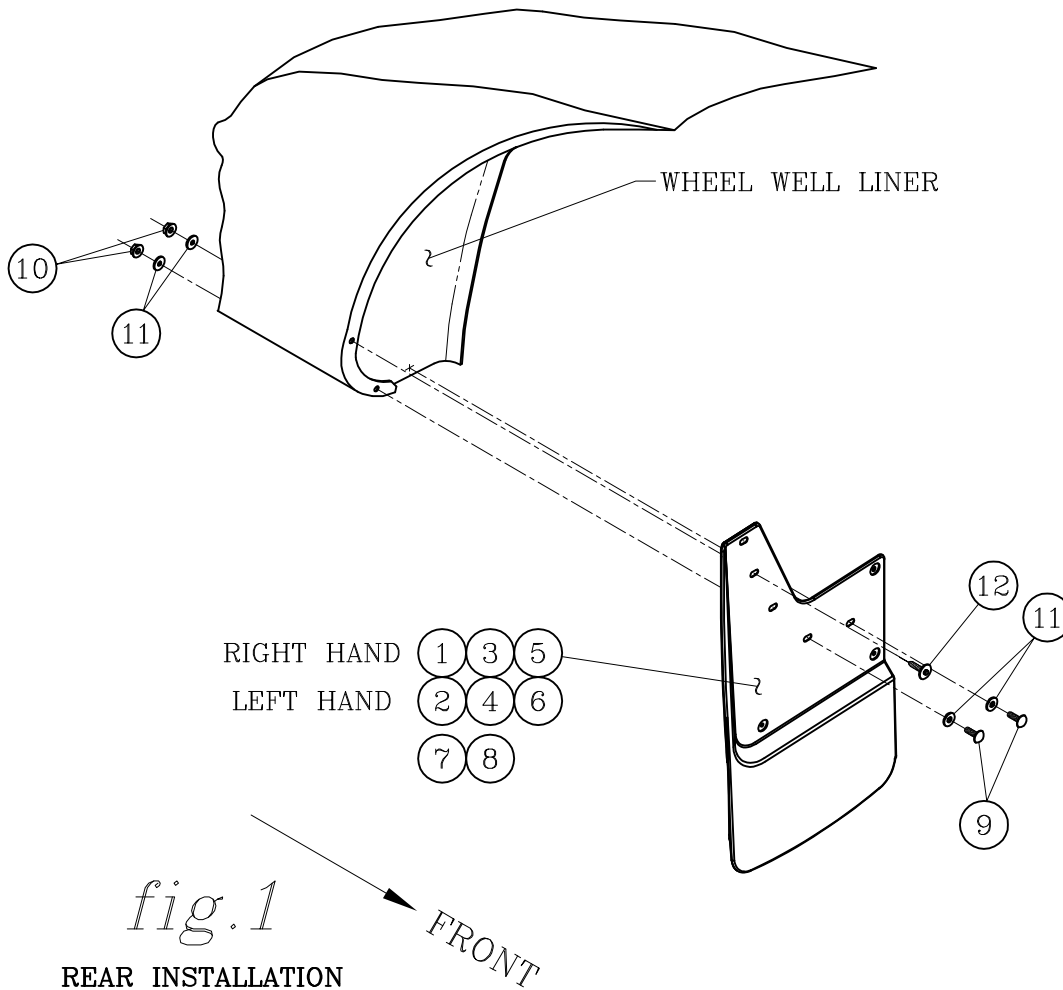

fig.1

REAR INSTALLATION

RIGHT (PASSENGER) SIDE SHOWN

ITEM	PART NO.	QTY	DESCRIPTION
1	550062	1	SPLASH GUARD-MOLDED,12 X 20,TAHOE/YUKON,RH
2	550063	1	SPLASH GUARD-MOLDED,12 X 20,TAHOE/YUKON,LH
3	550064	1	INSERT-SPLASH GUARD, SST, TAHOE/YUKON, RH
4	550065	1	INSERT-SPLASH GUARD, SST, TAHOE/YUKON, LH
5	550066	1	SPLASH GUARD-MOLDED,12 X 23,TAHOE/YUKON,RH
6	550067	1	SPLASH GUARD-MOLDED,12 X 23,TAHOE/YUKON,LH
7	103146	4	RIVET- SST, 3/16 X 3/8
8	105511	4	WASHER- FLAT, SST, .203 X .625 X .062
9	105543	4	SCREW- BTN HD SOC, SST, 1/4-20 X 1.00"
10	102366	4	NUT- HEX, SERR FLG, SST,1/4-20
11	101370	8	WASHER- FLAT, SST, .281 X .625 X .065
12	105514	2	SCREW- SEMS, 7mm, HEX HD, M4.2-1.41 X 30mm