

## INSTALLATION INSTRUCTIONS AND PARTS LIST

VEHICLE APPLICATION: MODEL 500740 (12.00" X 20.00") AND 500743 (12.00" X 23.00")

### NO DRILL FRONT OR REAR MOLDED SPLASH GUARDS

2007 AND NEWER GM PICKUPS

1. READ INSTRUCTIONS COMPLETELY AND CHECK TO MAKE SURE THAT ALL REQUIRED PARTS (LISTED ON SERVICE PARTS LIST) ARE ON HAND BEFORE STARTING THE INSTALLATION.
2. PEEL AWAY THE PROTECTIVE VINYL COVERING AND CLEAN THE STAINLESS STEEL SPLASH GUARD INSERTS TO REMOVE ANY RESIDUE. (A GOOD GLASS CLEANER IS SUGGESTED).
3. PREPARE THE SPLASH GUARDS FOR INSTALLATION AS FOLLOWS:
  - 3.1. FORM THE TOP OF THE SPLASH GUARD TO MATCH THE CONTOUR OF THE WHEEL WELL.

#### **MOUNTING 500740 OR 500743 SPLASH GUARDS ON THE FRONT: (SEE SHEET #3)**

4. INSTALL THE SPLASH GUARDS AS FOLLOWS:
  - 4.1. REMOVE TWO FACTORY HEX HEAD SEMS SCREWS (**THESE SCREWS ARE NOT REUSED**) AND THE BOTTOM INBOARD PLASTIC PUSH IN FASTENER THAT RETAIN THE WHEEL WELL LINER TO THE WHEEL WELL FLANGE.
  - 4.2. POSITION THE SPLASH GUARD AGAINST THE WHEEL WELL FLANGE AND FASTEN AS FOLLOWS. INSTALL TWO HEX HEAD SEMS SCREWS (ITEM#12) THRU THE TOP AND SECOND HOLE DOWN FROM THE TOP IN THE SPLASH GUARD. INSTALL A 1/4 X 1.00" SOCKET BUTTON HEAD SCREW (ITEM #9), 1/4" FLAT WASHER (ITEM #11) AND 1/4-20 SERR FLANGE NUT (ITEM #10) THRU THE BOTTOM INBOARD HOLE AS SHOWN.
  - 4.3. LOCATE THE SPLASH GUARD IN OR OUT AS DESIRED, LEVEL THE SPLASH GUARD AND TIGHTEN THE FASTENERS.

#### **MOUNTING 500740 OR 500743 SPLASH GUARDS ON THE REAR WITH NO DRILL CLIPS:**

(SEE SHEET # 2)

5. TAKE THE NO DRILL CLIP (ITEM #11) AND (ITEMS #9&10) AND A SPLASH GUARD AND ASSEMBLE AS FOLLOWS:
  - 5.1 ASSEMBLE CLIP (ITEM#11) AND U-NUT (ITEM#12) TOGETHER.
  - 5.2 STARTING WITH THE BOTTOM HOLE (ROUND HOLE) ASSEMBLE THE SCEW AND WASHER THOUGH THE SPLASH GUARD AND IN TO THE CLIP. **DO NOT TIGHTEN ALL THE WAY.**
  - 5.3 POSITION THE SPLASH GUARD AGAINST THE WHEEL WELL FLANGE AND HOOK THE CLIP BEHIND IT WITH THE SERRATED EDGE ON THE WHEEL WELL FLANGE. TIGHTEN FINGER TIGHT.
  - 5.4 ASSEMBLE REMAINING CLIPS (2) THE SAME AS BEFORE THIS TIME USING THE TWO TOP (OBLONG) HOLES AND MAKING SURE CLIPS HOOK BEHIND WHEEL WELL FLANGE. **(LIKE IN THE PICTURE ON SHEET #2)** AND FINGER TIGHTEN,
  - 5.5 LOCATE THE SPLASH GUARD IN OR OUT AS DESIRED, LEVEL THE SPLASH GUARD AND TIGHTEN FASTENERS

#### **MOUNTING 500740 OR 500743 SPLASH GUARDS ON REAR WITH FENDER WELL LINER:**

##### **DRILL APPLICATION**

1. HOLD SPLASH GUARD UP AND LINE HOLES UP WITH FENDER FLANGE SO THAT ALL 3 HOLES LINE UP ON CENTER OF THE FLANGE MARK HOLES. DRILL 5/16" HOLES.
2. SLIDE U-NUT (ITEM#12) ON TO EACH DRILLED HOLE, THEN PLACE SPLASH GUARD ON LINING THE HOLES IN SPLASH GUARD UP WITH U-NUTS, FASTEN WITH SCREW AND WASHER (ITEMS #9&10).
3. LOCATE THE SPLASH GUARD IN OR OUT AS DESIRED, LEVEL THE SPLASH GUARD AND TIGHTEN THE FASTENERS.



REVISED 20OCT10 LVL B  
REVISED 27JUL09 LVL A  
550074 SHEET 1 OF 3 09NOV06

SERVICE PARTS LIST

2007 GM PICKUPS  
MODEL NO. - 500740 & 500743

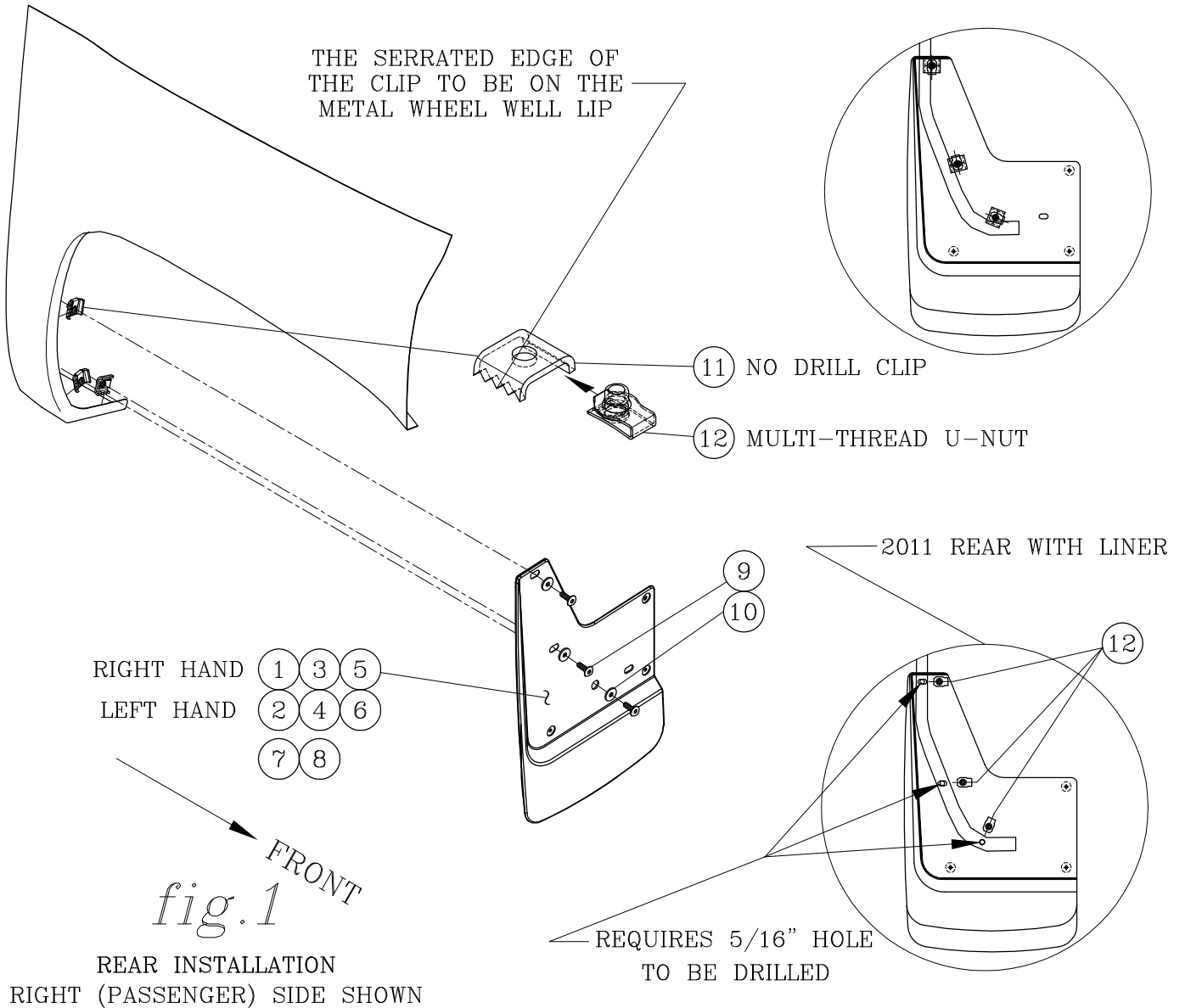

ITEM	PART NO.	QTY	DESCRIPTION
1	550070	1	SPLASH GUARD-MOLDED,12 X 20,07,GM PICKUPS,RH
2	550071	1	SPLASH GUARD-MOLDED,12 X 20,07,GM PICKUPS,LH
3	550068	1	INSERT-SPLASH GUARD, SST, 07,GM PICKUPS,RH
4	550069	1	INSERT-SPLASH GUARD, SST, 07,GM PICKUPS,LH
5	550072	1	SPLASH GUARD-MOLDED,12 X 23,07,GM PICKUPS,RH
6	550073	1	SPLASH GUARD-MOLDED,12 X 23,07,GM PICKUPS,LH
7	103146	6	RIVET- SST, 3/16 X 3/8
8	105511	6	WASHER- FLAT, SST, .203 X .625 X .062
9	105543	6	SCREW- BTN HD SOC, SST, 1/4-20 X 1.00"
10	101370	6	WASHER- FLAT, SST, .281 X .625 X .065
11	550058	6	BRKT-NO DRILL CLIP 07 GM PICKUP
12	106604	6	MULTI-THRD,U-NUT 1/4 X 20

REVISED 20OCT10 LVL B  
REVISED 27JUL09 LVL A  
550074 SHEET 2 OF 3 10NOV06