

INSTALLATION INSTRUCTIONS AND PARTS LIST

VEHICLE APPLICATION:

MODEL 501544 (20.25" X 23.00") DUAL WHEEL SPLASH GUARDS
2015 AND NEWER GM SILVERADO/ SIERRA 3500 HD SERIES DUAL WHEEL TRUCKS

1. READ INSTRUCTIONS COMPLETELY AND CHECK TO MAKE SURE THAT ALL REQUIRED PARTS (LISTED ON SERVICE PARTS LIST) ARE ON HAND BEFORE STARTING THE INSTALLATION.
2. PEEL AWAY THE PROTECTIVE VINYL COVERING AND CLEAN THE STAINLESS STEEL SPLASH GUARD INSERTS TO REMOVE ANY VINYL COVERING RESIDUE. (A GOOD GLASS CLEANER IS SUGGESTED).
3. PREPARE THE SPLASH GUARDS AND VEHICLE FOR SPLASH GUARD INSTALLATION AS FOLLOWS:
 - 3.1. FORM THE TOP OF THE SPLASH GUARD ASSEMBLY (ITEM #1 THRU #4) TO MATCH THE CONTOUR OF THE WHEEL WELL.
 - 3.2. REMOVE THE FACTORY FENDER STIFFENER BRACE SCREW. (THIS FASTENER IS REUSED IN THIS INSTALLATION).
 - 3.3. REMOVE THE TWO FACTORY WHEEL WELL FLANGE SCREWS. (THESE FASTENERS ARE NOT REUSED IN THIS INSTALLATION).
4. INSTALL THE SPLASH GUARDS AS FOLLOWS:
 - 4.1. ATTACH THE MOUNTING BRACKET (ITEM #5) TO THE SPLASH GUARD AS SHOWN. USE 1/4-20 X 3/4" CARRIAGE BOLT (ITEM #6), 1/4" FLAT WASHER (ITEM #8) AND 1/4-20 SERRATED FLANGE NUT (ITEM #7).
 - 4.2. POSITION THE SPLASH GUARD AGAINST THE WHEEL WELL FLANGE AND RE-INSTALL THE FACTORY STIFFENER BRACE SCREW THRU THE MOUNTING BRACKET AS SHOWN.
 - 4.3. INSTALL M6-1.0 X 30MM BTN HD SOC SCREWS (ITEM #9) AND 1/4" FLAT WASHER (ITEM #8) AS SHOWN. (USE THE OUTBOARD HOLES IN THE SPLASH GUARD AS SHOWN).
 - 4.4. MOVE THE SPLASH GUARDS IN OR OUT AS DESIRED, LEVEL THE SPLASH GUARDS AND TIGHTEN THE FASTENERS.



SERVICE PARTS LIST

2015 GM SILV/SIERRA DUALY
MODEL NO. - 501544

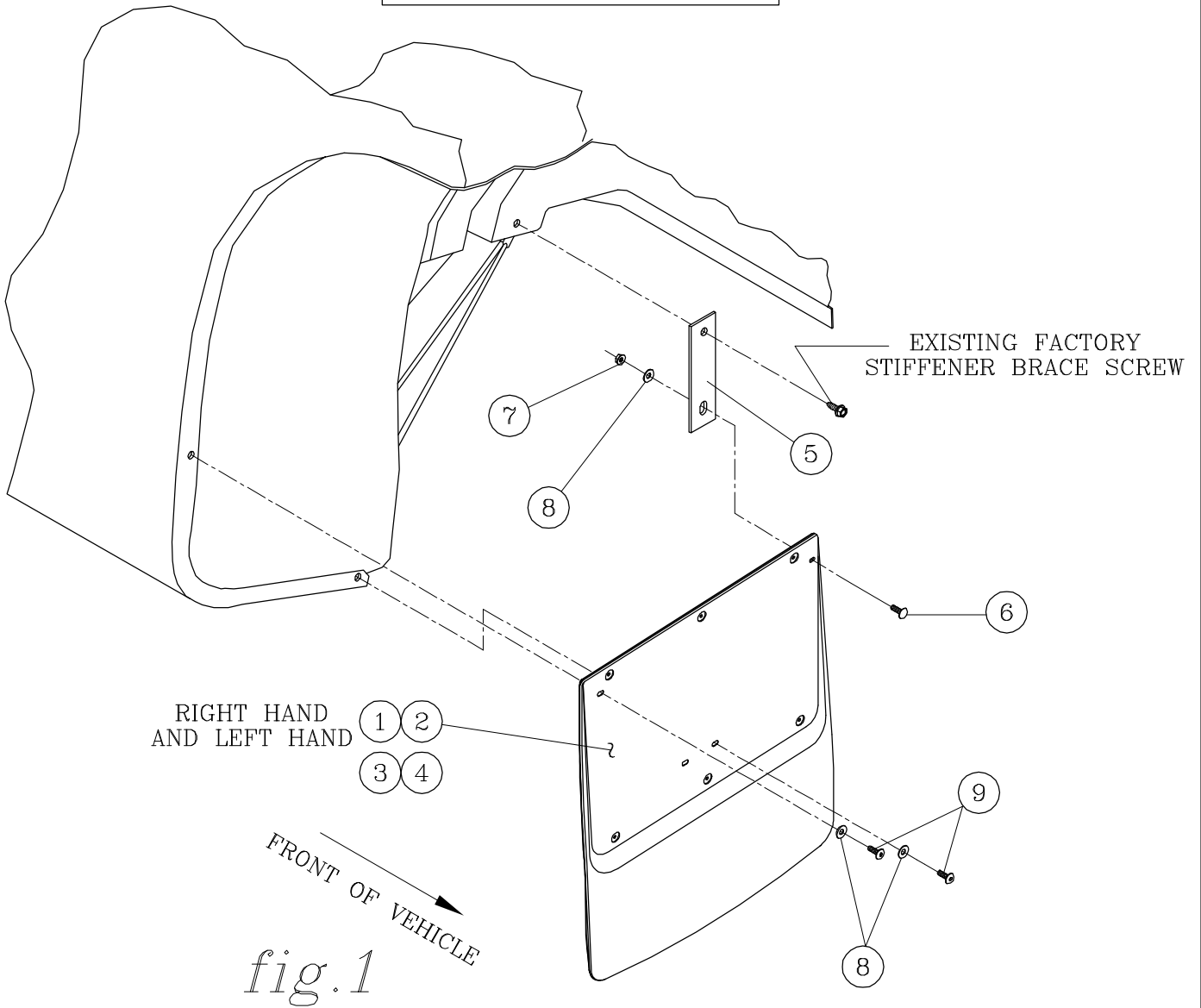

RIGHT (PASSENGER) SIDE SHOWN

ITEM	PART NO.	QTY	DESCRIPTION
1	552317	2	SPLASH GUARD- MOLDED, 20.25" X 23.00", GM, RH/LH
2	552318	2	INSERT- SPLASH GUARD, SST, GM, RH/LH
3	103146	12	RIVET- SST, 3/16 X 3/8
4	105511	12	WASHER- FLAT, SST, .203 X .625 X .062
5	549993	2	BRACKET - MOUNTING,LH/RH 500744
6	100008	2	BOLT - CARRIAGE, SST, 1/4-20 X 3/4"
7	102366	2	NUT-HEX,SERRATED, FLANGE,SST,1/4-20
8	101370	6	WASHER-FLAT,SST,.281 X .625 X .065
9	106640	4	SCREW - BTN HD SOC, SST, M6 X 1.00 X 30MM



(A LUVERNE Company)

1200 E. Birch St.

Brandon, SD 57005

552319 SHEET 2 OF 2 28APR14