

INSTALLATION INSTRUCTIONS AND PARTS LIST

APPLICATION:
MODEL 571124 MEGA STEPS:
2011 FORD EXPLORER

1. READ INSTRUCTIONS COMPLETELY AND CHECK TO MAKE SURE THAT ALL REQUIRED PARTS (LISTED ON THE SERVICE PARTS LIST) ARE ON HAND BEFORE STARTING THE INSTALLATION.
2. ATTACH THE MOUNTING BRACKETS TO THE CAB OF THE VEHICLE AS FOLLOWS:
 - 2.1 ON THE DRIVERS SIDE MEASURE FROM THE PINCH WELD AT THE FRONT WHEEL WELL OPENING TO THE REAR OF VEHICLE AND PLACE A MARK AT 11 1/8", AND 64 5/8". THEN MEASURE UP FROM BOTTOM OF THE PINCH WELD 1/2", AT BOTH OF THOSE LOCATIONS THIS WILL GIVE YOU YOUR CENTER POINT FOR DRILLING, SEE (FIGURE 1).
 - 2.2 DRILL A PILOT HOLE AT BOTH THE FRONT AND REAR LOCATIONS, AND THEN DRILL AN 11/32" HOLE IN BOTH PLACES. **NOTE: PLACE A SCRAP PIECE OF METAL OR WOOD BETWEEN THE PLASTIC ROCKER, AND THE PINCH WELD TO AVOID DRILLING THROUGH THE PLASTIC WHEN DRILLING PINCH WELDS.**
 - 2.3 INSERT 5/8" CLIPPED HEAD BOLT (ITEM #4) INTO THE LARGE SLOT LOCATED ON THE ANGLED PORTION OF THE INNER ROCKER PANEL AT BOTH FRONT AND REAR LOCATIONS. SEE (FIGURE 2.) FOR SLOT LOCATIONS, AND SEE (FIGURE 3.) ON HOW TO INSERT CLIPPED HEAD BOLT INTO SLOT.
 - 2.4 PUSH 5/16" U-NUT (ITEM #11) ONTO PINCH WELD IN THE LOCATIONS THAT YOU DRILLED THE 11/32" HOLES. SEE (FIGURE 4.) ON HOW TO INSTALL.
 - 2.5 INSTALL FRONT MOUNTING BRACKET (ITEM #1) USING 5/8" FLAT WASHER, 5/8" LOCK WASHER, AND A 5/8" SERRATED FLANGE NUT (ITEMS #5,6,7) ONTO THE 5/8" CLIPPED HEAD BOLT (ITEM #4) PREVIOUSLY INSERTED INTO THE FRONT SLOT, LEAVE IT FINGER TIGHT. THEN INSERT THE 5/16"-18 X 1" SCREW (ITEM #8), THE 5/16" LOCK WASHER (ITEM#9), AND THE 5/16" FLAT WASHER (ITEM #10), THROUGH THE BRACKET AND INTO THE U-NUT, AND TIGHTEN TO 19 LB FT, THEN TIGHTEN 5/8"-11 UNC SERRATED FLANGE NUT (ITEM #7) TO 154 LB FT.
 - 2.6 INSTALL REAR BRACKET (ITEM#3) FOLLOWING THE PREVIOUS STEP (2.5).
 - 2.7 MEASURE FROM THE FRONT EDGE OF THE FRONT BRACKET BACK APPROXIMATELY 26 3/4" AND MAKE A MARK ON INNER ROCKER PANEL, THEN PLACE THE MIDDLE BRACKET (ITEM#2) UP IN THIS LOCATION AND TRACE THE 3 BOLT HOLES ONTO THE INNER ROCKER PANEL. **NOTE: MAKE SURE BRACKET IS STRAIGHT BEFORE MARKING HOLES.**
 - 2.8 DRILL A PILOT HOLE IN THE CENTER OF THOSE 3 LOCATIONS, AND THEN DRILL ALL 3 HOLES TO A 17/64" HOLE.
 - 2.9 INSTALL MIDDLE BRACKET (ITEM #2) USING 5/16"-18 X 1" SELF THREADING SCREWS (ITEM #14), AND 5/16" LOCK WASHERS (ITEM #9), IN ALL 3 HOLES IN BRACKET. TIGHTEN BOLTS TO 10 LB FT. **NOTE: DO TO THE THIN MATERIAL THESE BOLTS ARE THREADING INTO, IT IS VERY IMPORTANT NOT TO OVER TIGHTEN THESE 3 SCREWS, AS STRIPPING WILL OCCUR.**
 - 2.10 REPEAT STEPS 2.1 THRU 2.9 ON THE PASSENGER SIDE.
3. PREPARE THE MEGA STEP PLATE FOR MOUNTING BY INSERTING THREE 5/16" SQUARE HEAD SCREWS (ITEM #12) IN THE CENTER SLOT ON THE UNDER SIDE OF THE STEP.



4. POSITION THE MEGA STEP ON THE MOUNTING BRACKETS SO THAT THE SQUARE HEAD SCREWS ARE LOCATED IN THE SLOTS OF THE MOUNTING BRACKETS AND THE STEP IS CENTERED, FRONT TO REAR, ON THE VEHICLE. INSTALL 5/16" SERRATED FLANGE NUTS (ITEM #13) ON THE SQUARE HEAD SCREWS AND TIGHTEN TO 19 LB FT.

SERVICE PARTS LIST

ITEM	PART NO.	QTY	DESCRIPTION
1	552001	2	BRKT-MTG, R/L-FRONT, MEGA-STEP,571124
2	551999	2	BRKT-MTG, R/L-MIDDLE, MEGA-STEP,571124
3	552000	2	BRKT-MTG, R/L-REAR, MEGA-STEP,571124
4	104692	4	5/8"-11 UNC X 2" CLIPPED HEAD BOLT ZP
5	100147	4	5/8" FLAT WASHER ZP
6	100148	4	5/8" LOCK WASHER ZP
7	105643	4	5/8"-11 UNC SERRATED FLANGE NUT ZP
8	100647	4	5/16"-18 X 1" SCREW ZP
9	100030	10	5/16" LOCK WASHER ZP
10	100034	4	5/16" FLAT WASHER ZP
11	104264	4	5/16"-18 UNC U-NUT
12	106880	6	SCREW-SQUARE HD, 5/16"-18 UNC X 1"
13	102680	12	5/16"-18 UNC SERRATED FLANGE NUT SST
14	109177	6	5/16"-18 X 1", SELF THREADING SCREW



SERVICE PARTS LIST

MODEL NO. - 571124

Fig. 1

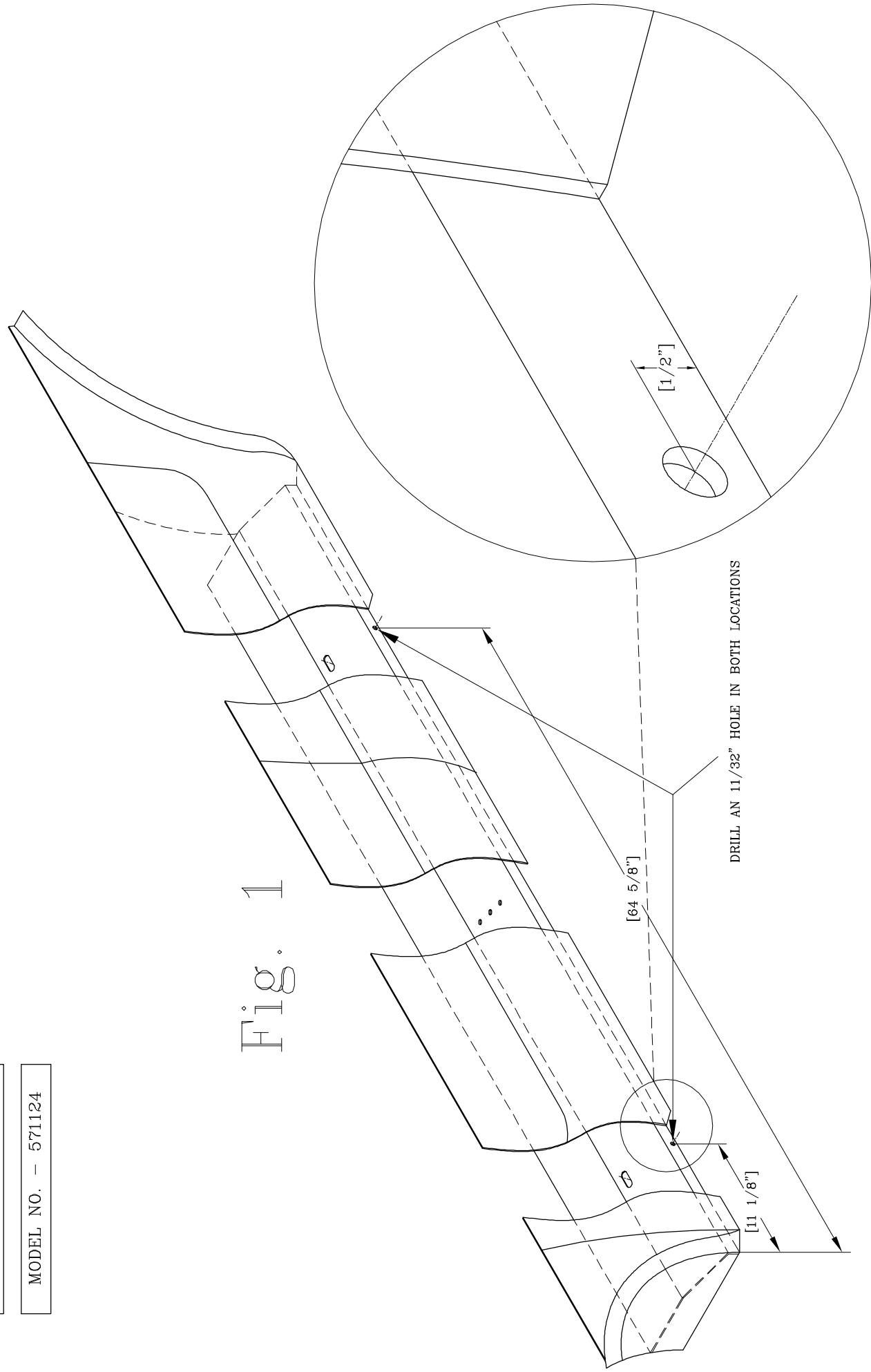

LIVERNE TRUCK
EQUIPMENT
INC.
1200 Birch Street
Brandon, SD 57005

SERVICE PARTS LIST

MODEL NO. - 571124

Fig. 3

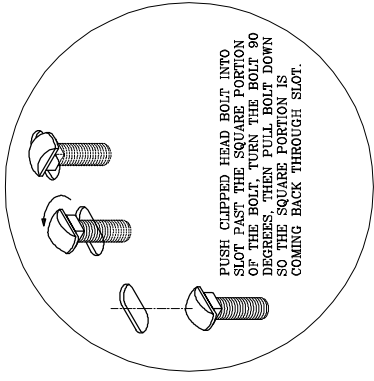

Fig. 2

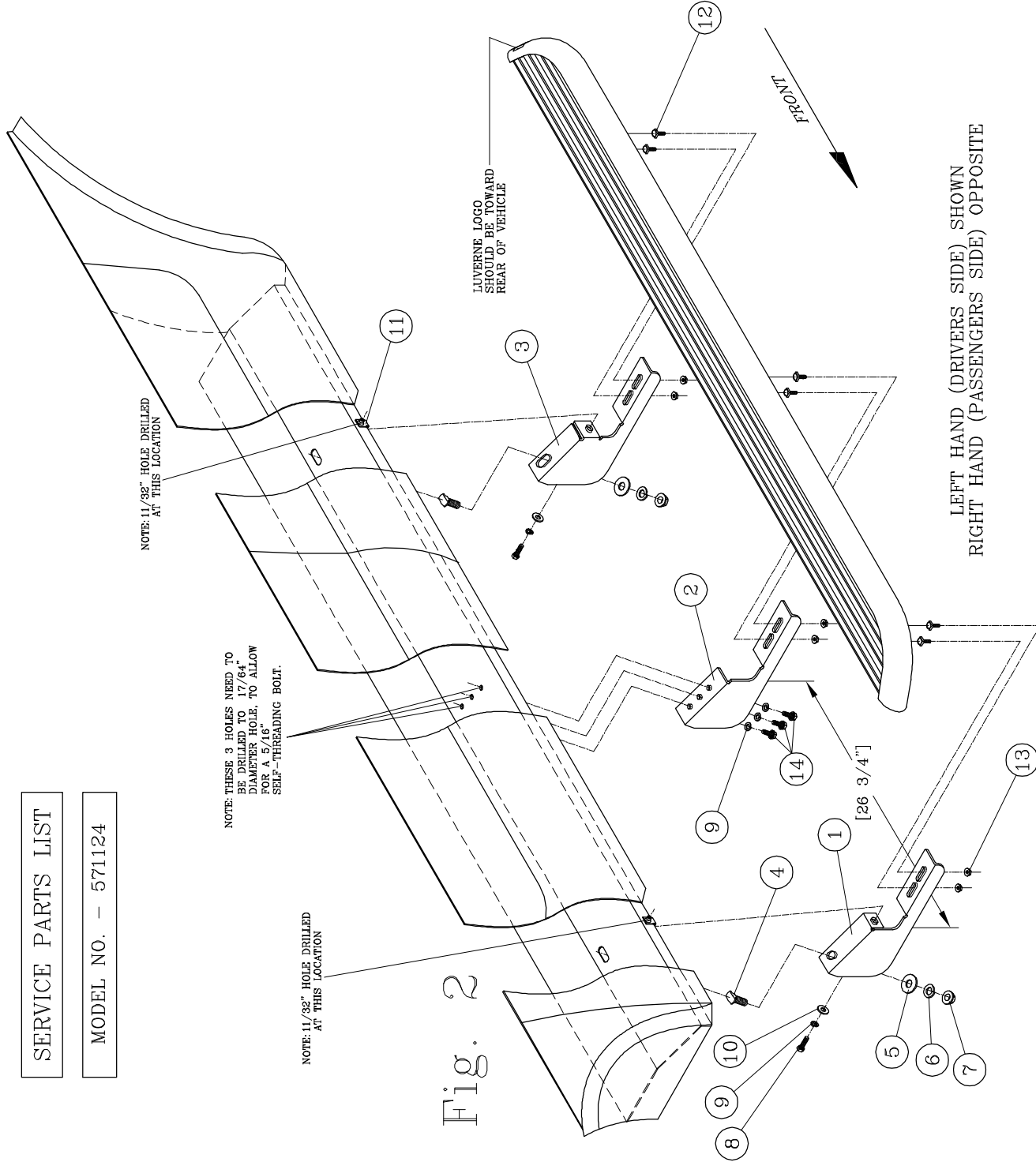
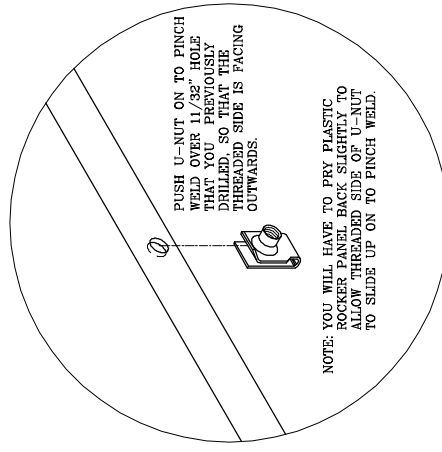

Fig. 4



NOTE: BOARD, AND MOUNTING HARDWARE ARE FOR VISUAL AID ONLY.

LIVERNE TRUCK EQUIPMENT INC.
1200 Birch Street
Brandon, SD 57005