

INSTALLATION INSTRUCTIONS AND PARTS LIST

MODEL 583054, 583060, 584054 O-MEGA II 6" OVAL STEPS

1. READ INSTRUCTIONS COMPLETELY AND CHECK TO MAKE SURE THAT ALL REQUIRED PARTS (LISTED ON THE SERVICE PARTS LIST) ARE ON HAND BEFORE STARTING THE INSTALLATION.
2. FOLLOW THE INSTRUCTIONS INCLUDED WITH THE SPECIFIC BRACKET PACKAGE THAT YOU ARE USING, TO MOUNT THE BRACKETS TO YOUR VEHICLE.
3. BEFORE ATTACHING THE O-MEGA STEPS TO THE BRACKETS, PLACE THE STEP PADS (ITEM #2) ON TOP OF THE STEP PLATES. USE THE TABLE ON SHEET #2, AS A GUIDE TO POSITION THE STEP PAD FOR YOUR PARTICULAR VEHICLE. WHEN INSTALLING THE PADS ON THE STEPS, DRILL (5) 1/8" HOLE USING THE STEP PAD AS A GUIDE. ATTACH WITH (5) 8-18X1/2" TEK SCREWS (ITEM #6) PROVIDED. REPEAT FOR ALL STEP PADS.
4. INSTALL THE REQUIRED NUMBER OF SQUARE HEAD BOLTS INTO THE DESIGNATED SLOTS IN THE BOTTOM OF THE STEP PLATES.
5. INSTALL THE END CAPS (ITEM #3) AS SHOWN IN *fig. 1* SNUG UP THE NUTS. BE CAREFUL NOT TO DEFORM THE PLASTIC
6. POSITION THE O-MEGA STEP ON THE MOUNTING BRACKETS SO THAT THE SQUARE HEAD SCREWS (ITEM #4) ARE LOCATED IN THE SLOTS OF THE MOUNTING BRACKETS AND THE STEP IS CENTERED, FRONT TO REAR, ON THE VEHICLE. INSTALL 5/16" SERRATED FLANGE NUTS (ITEM #5) ON THE SQUARE HEAD SCREWS (ITEM #4) AND TIGHTEN TO 19 LB FT.

SERVICE PARTS LIST

ITEM	PART NO.	QTY	DESCRIPTION
1	553069	2	EXTRUSION-AL,51.0,OMEGA STP,SILVER
1	553057	2	EXTRUSION-AL,51.0,OMEGA STP,BLACK
1	553070	2	EXTRUSION-AL,57.0,OMEGA STP,SILVER
2	552970	4	ALUM,STP-PAD,BLK,OMEGA-STEPS
3	107956	4	CAP-END,PLSTC,2.95 X 6.70
4	106880	20	SCREW-SQ HD,5/16-18 X 1,MAGNIGUARD
5	102680	20	NUT-SERR FLG,HX,SST,WX,5/16-18
6	107958	20	SCREW-PPH,TEK,#8-18 X 1/2",SST,BZP



STEP PAD LOCATION GUIDE

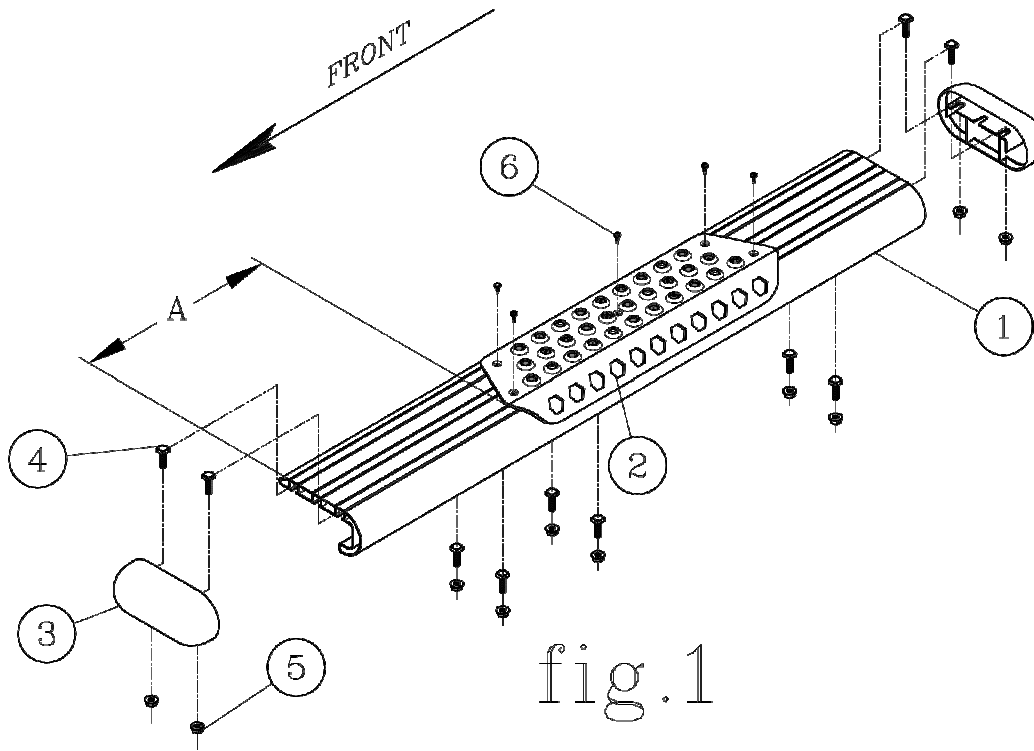

VEHICLE MODEL	PAD A	PAD B
SILVERADO/SIERRA REGULAR CAB	14-3/4	N/A
DODGE RAM REGULAR CAB	10-1/2	N/A
FORD F150 REGULAR CAB	18-1/4	N/A
FORD SUPER DUTY REGULAR CAB	6-7/8	N/A
TUNDRA REGULAR CAB	6-1/2	N/A
TOYOTA FJ CRUSIER	6-1/2	N/A
FORD ESCAPE	5-1/2	35-1/2

NOTE: THE ABOVE PAD LOCATIONS ARE ONLY SUGGESTIONS AND MAY BE PLACED AT THE PURCHASERS DISCRETION. (THE 2008-2012 FORD ESCAPE WILL USE 2 PADS PER SIDE ON THE 585060 BOARDS).



INSTALLATION INSTRUCTIONS AND PARTS LIST

APPLICATION: MODEL 571441 MEGA STEP BRACKETS ON:

2014+ GM 1500 REGULAR CAB PICKUPS, GAS

2015 GM 2500/3500HD REGULAR CAB PICKUPS, GAS

ROCKER PANEL MOUNT APPLICATION



NO DRILL APPLICATION

1. READ INSTRUCTIONS COMPLETELY AND CHECK TO MAKE SURE THAT ALL REQUIRED PARTS (LISTED ON SERVICE PARTS LIST) ARE ON HAND BEFORE STARTING THE INSTALLATION. THE SIDE ENTRY STEP ASSEMBLIES SHOULD BE MOUNTED TO THE PINCH WELD AND VERTICAL WALL OF THE ROCKER PANEL AS FOLLOWS. **NOTE: DEPENDING ON THE VEHICLE, THE HOLE CONFIGURATION MAY CHANGE. FASTENERS ARE PROVIDED FOR ALL APPLICATIONS.**
2. ON THE LEFT SIDE OF THE VEHICLE REMOVE THE PLASTIC BODY PLUGS THAT ARE LOCATED ON THE VERTICAL WALL OF THE ROCKER PANEL AND INSERT A 5/16"-18 U-NUT (ITEM #7) AS SHOWN. (IF THERE ARE THREADED INSERTS IN THE UPPER LOCATION, USE THE BLACK M8-1.25X30 BOLTS (ITEM #)).
3. POSITION THE MOUNTING BRACKETS (ITEM #3) SO THAT THE HOLES ON THE BRACKET LINE UP WITH THE HOLES ON THE INSIDE WALL OF THE ROCKER PANEL. INSTALL A 5/16"-18 X 1.0" HEX BOLT, AND A 5/16" FLAT WASHER (ITEMS #5, 4) FINGER TIGHT.
4. INSTALL A BLACK M8-1.25 X 30MMHEX BOLT, 5/16" FLAT WASHER, AND THE PINCH WELD SUPPORT (ITEMS #4, 8, 9) THROUGH THE HOLE AND INSTALL A M8-1.25 NUT (ITEM #6) FINGER TIGHT ON THE BACK AS SHOWN.
5. REPEAT STEPS 3 – 4 FOR THE REMAINING BRACKETS.
6. INSTALL THE STEP BOARD AS DESCRIBED BY THE INSTRUCTIONS INCLUDED WITH YOUR STEP BOARDS.
7. PRESS STEP DOWN AND BACK, TIGHTEN THE MOUNTING BOLTS TO 19 LB-FT STARTING WITH THE BOTTOM BOLTS FOLLOWED BY THE TOP BOLTS.
8. REPEAT STEPS 2 – 7 FOR THE RIGHT SIDE OF THE VEHICLE.

SERVICE PARTS LIST

ITEM	PART NO.	QTY	DESCRIPTION
1		1	STEP ASSEMBLY, MEGA STEP / O-MEGA STEP
2	552628	2	BRKT-MTG, LH, MEGA STEP, 571441
3	552627	2	BRKT-MTG, RH, MEGA STEP, 571441
4	106998	8	5/16" FLATWASHER, SST, BZP
5	100647	4	5/16"-18 X 1.00" SCR ZP
6	105859	4	NUT SERR FLG, M8-1.25, ZP
7	105541	4	U-NUT,5/16"-18
8	551666	4	BRKT-MTG,PINCH WELD SUPPORT
9	100180	4	M8-1.25 X 30MM, SCR, SST, BZP



SERVICE PARTS LIST

MODEL NO. -571441

GM REGULAR CAB

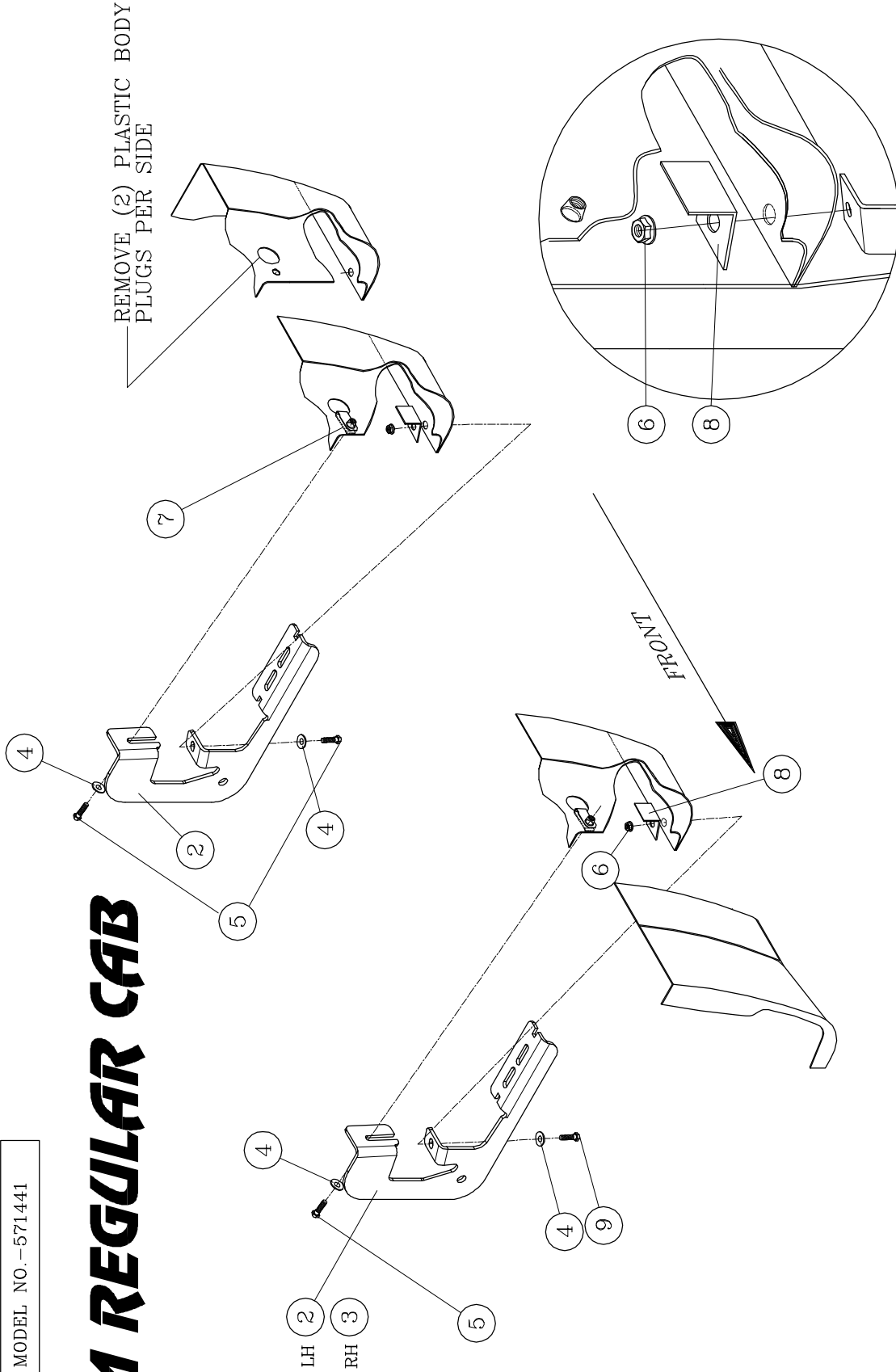

PINCH WELD SUPPORT ASSEMBLY



1280 E. Birch St. Spindon, SB 57606

LEFT (DRIVER) SIDE SHOWN
- RIGHT (PASSENGER) SIDE OPPOSITE -