

INSTALLATION INSTRUCTIONS AND PARTS LIST
MODEL 583072, 583078, 583088, 584072, 584078, 584088 O-MEGA II 6" OVAL STEPS
 UNIVERSAL APPLICATION

1. READ INSTRUCTIONS COMPLETELY AND CHECK TO MAKE SURE THAT ALL REQUIRED PARTS (LISTED ON THE SERVICE PARTS LIST) ARE ON HAND BEFORE STARTING THE INSTALLATION.
2. FOLLOW THE INSTRUCTIONS INCLUDED WITH THE SPECIFIC BRACKET PACKAGE THAT YOU ARE USING, TO MOUNT THE BRACKETS TO YOUR VEHICLE.
3. BEFORE ATTACHING THE O-MEGA STEPS TO THE BRACKETS, PLACE THE STEP PADS (ITEM #2) ON TOP OF THE STEP PLATES. USE THE TABLE ON SHEET #2, AS A GUIDE TO POSITION THE STEP PAD FOR YOUR PARTICULAR VEHICLE. WHEN INSTALLING THE PADS ON THE STEPS, DRILL (5) 1/8" HOLE USING THE STEP PAD AS A GUIDE. ATTACH WITH (5) 8-18X1/2" TEK SCREWS (ITEM #6) PROVIDED. REPEAT FOR ALL STEP PADS.
4. INSTALL THE REQUIRED NUMBER OF SQUARE HEAD BOLTS INTO THE DESIGNATED SLOTS IN THE BOTTOM OF THE STEP PLATES.
5. INSTALL THE END CAPS (ITEM #3) AS SHOWN IN *fig. 1*, TIGHTENING THE NUTS TO 5 LB FT.
6. POSITION THE O-MEGA STEP ON THE MOUNTING BRACKETS SO THAT THE SQUARE HEAD SCREWS (ITEM #4) ARE LOCATED IN THE SLOTS OF THE MOUNTING BRACKETS AND THE STEP IS CENTERED, FRONT TO REAR, ON THE VEHICLE. INSTALL 5/16" SERRATED FLANGE NUTS (ITEM #5) ON THE SQUARE HEAD SCREWS (ITEM #4) AND TIGHTEN TO 19 LB FT.

SERVICE PARTS LIST

ITEM	PART NO.	QTY	DESCRIPTION
1	553071	2	EXTRUSION-AL,69.0,OMEGA STP,SILVER
1	553072	2	EXTRUSION-AL,75.0,OMEGA STP,SILVER
1	553073	2	EXTRUSION-AL,85.0,OMEGA STP,SILVER
1	553059	2	EXTRUSION-AL,69.0,OMEGA STP,BLACK
1	553060	2	EXTRUSION-AL,75.0,OMEGA STP,BLACK
1	553061	2	EXTRUSION-AL,85.0,OMEGA STP,BLACK
2	552970	4	ALUM,STP-PAD,BLK,OMEGA-STEP
3	107956	4	CAP-END,PLSTC,2.95 X 6.70
4	106880	24	SCREW-SQ HD,5/16-18 X 1,MAGNIGUARD
5	102680	24	NUT-SERR FLG,HX,SST,WX,5/16-18
6	107958	20	SCREW-PPH,TEK,#8-18 X 1/2",SST,BZP



STEP PAD LOCATION GUIDE

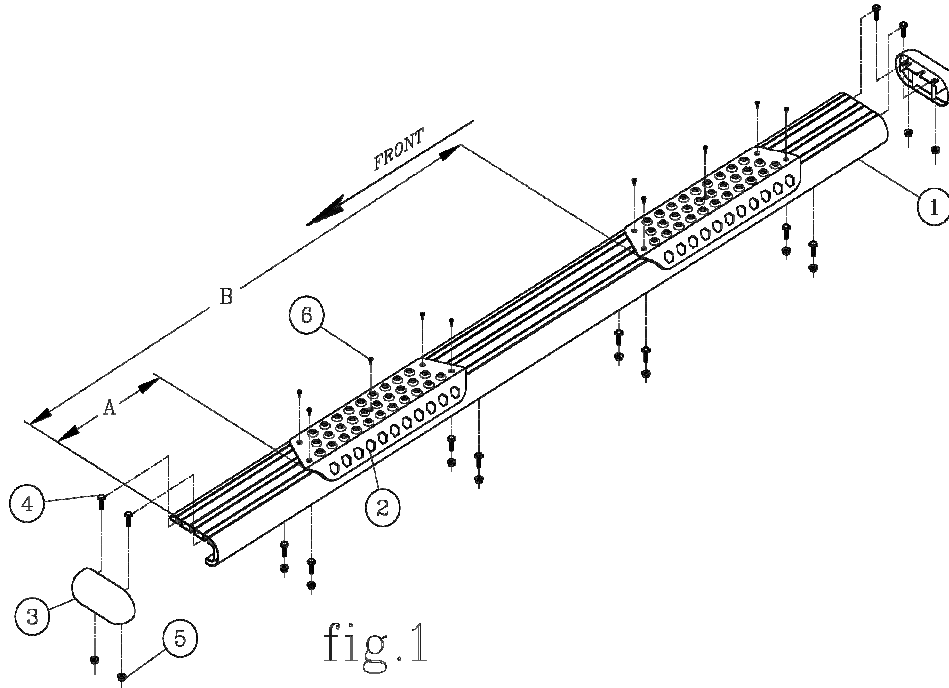

VEHICLE MODEL	PAD A	PAD B
SILVERADO/SIERRA DOUBLE CAB	14-3/4	46-3/4
SILVERADO/SIERRA EXTENDED CAB	14-3/4	41-3/4
SILVERADO/SIERRA CREW CAB	14-3/4	54-1/4
COLORADO/CANYON EXTENDED CAB	10-1/2	43
COLORADO/CANYON CREW CAB	10-1/2	51
AVALANCHE/SUBURBAN/YUKON XL	15-1/4	55-1/4
TAHOE/YUKON	15-1/4	48-1/4
RAM QUAD CAB	10-1/2	46
RAM CREW CAB	10-1/2	48
RAM MEGA CAB	10-1/2	52-1/16
DODGE DAKOTA QUAD CAB	10-1/2	39
DODGE DURANGO	15-1/4	50-1/4
FORD F150 SUPER CAB	18-1/4	46-1/4
FORD F150 SUPER CREW CAB	18-1/4	56-1/2
FORD SUPER DUTY SUPER CAB	14-1/4	42
FORD SUPER DUTY CREW CAB	12	58-1/4
TOYOTA TUNDRA DOUBLE CAB 07+	8-1/4	49-1/4
TOYOTA TUNDRA CREWMAX07+	8-1/4	54-1/4
TOYOTA TACOMA ACCESS CAB	8-1/4	30-1/5
TOYOTA TACOMA DOUBLE CAB	18-3/4	55-1/4

NOTE: THE ABOVE PAD LOCATIONS ARE ONLY SUGGESTIONS AND MAY BE PLACED AT THE PURCHASERS DISCRETION.



INSTALLATION INSTRUCTIONS AND PARTS LIST

MODEL 570412 MEGA STEP BRACKETS:

2004 AND NEWER CHEVROLET COLORADO AND GMC CANYON EXTENDED AND CREW CAB PICKUPS



1. READ INSTRUCTIONS COMPLETELY AND CHECK TO MAKE SURE THAT ALL REQUIRED PARTS (LISTED ON SERVICE PARTS LIST) ARE ON HAND BEFORE STARTING THE INSTALLATION.
2. A FACTORY SLOTTED HOLE PATTERN IS LOCATED ALONG THE SIDEWALL OF THE VEHICLE FRAME. THESE HOLES ARE USED AS MOUNTING HOLES FOR THIS INSTALLATION PER THE FOLLOWING INSTRUCTIONS.
 - 2.1. **ON EXTENDED CAB APPLICATIONS:** FROM THE FRONT OF THE VEHICLE, USE THE FIRST (1), FOURTH (4), FIFTH (5) AND SEVENTH (7) SLOTTED MOUNTING HOLES.
 - 2.2. **ON CREW CAB APPLICATIONS:** FROM THE FRONT OF THE VEHICLE, USE THE FIRST (1), FOURTH (4), SIXTH (6) AND SEVENTH (7) SLOTTED MOUNTING HOLES.
 - 2.3. ASSEMBLE A POLYETHYLENE "FOAM" WASHER (ITEM #8) AND SINGLE THREAD LOCKING PALNUT (ITEM #9), WITH THE FLAT SURFACE TOWARD THE FOAM WASHER, ON THE 5/8-11UNC X 2.00" CLIPPED HEAD CARRIAGE BOLTS (ITEM #6). (HAND TIGHTEN THE PALNUT).
 - 2.4. INSERT THE CLIPPED HEAD OF THE CARRIAGE BOLT THRU THE FRAME MOUNTING HOLES AS INDICATED ABOVE. PUSH THE BOLT INWARD AND TURN TO BOLT 90 DEGREES TO LOCK THE SQUARE NECK OF THE BOLT INTO THE HOLE.
3. ATTACH THE MOUNTING BRACKETS (ITEM #2 & #3) ON THE OUTBOARD SIDE OF THE FRAME AS SHOWN.
 - 3.1. INSTALL THE 1-3/4" OD FLAT WASHERS (ITEM #10), 5/8" LOCK WASHER (ITEM #11) AND 5/8" HEX NUT (ITEM #7) ON THE CARRIAGE BOLT.
 - 3.2. SLIDE THE MOUNTING BRACKETS UP BETWEEN THE FRAME AND THE FLAT WASHERS. LOCATE THE BRACKET SO THAT THERE IS A 1-3/4" GAP BETWEEN THE BOTTOM OF THE ROCKER PANEL PINCH WELD AND THE TOP OF THE BRACKET STEP MOUNTING SURFACE.
 - 3.3. TORQUE THE 5/8" FASTENERS TO 40 LB. FT.
4. ATTACH THE STEP (ITEM #1) TO THE MOUNTING BRACKETS.
 - 4.1. INSERT FOUR (4) 5/16" SQUARE HEAD SCREWS (ITEM #4) IN THE CENTER SLOT ON THE UNDER SIDE OF EACH STEP.
 - 4.2. POSITION THE STEP ON THE MOUNTING BRACKETS SO THAT THE SQUARE HEAD SCREWS ARE LOCATED IN THE SLOTS OF THE MOUNTING BRACKETS AND THE STEP IS CENTERED, FRONT TO REAR, ON THE VEHICLE.
 - 4.3. LOCATE THE STEP, IN AND OUT, AS DESIRED, INSTALL 5/16" SERRATED FLANGE NUTS (ITEM #5) ON THE SQUARE HEAD SCREWS AND TIGHTEN TO 19 LB FT.

SERVICE PARTS LIST

ITEM	PART NO.	QTY	DESCRIPTION
1		2	MEGA STEP BOARD ASSEMBLY (SOLD SEPARATELY) LENGTH WILL VARY DEPENDING ON APPLICATION
2	551737	2	BRKT- MTG, MS, RH/LH FRONT, GM COLORADO/CANYON
3	551738	6	BRKT- MTG, MS, RH/LH, GM COLORADO/CANYON
4	106880	8	SCREW-SQUARE HEAD, 5/16_18 UNC
5	102680	16	NUT-SERRATED FLANGE, HEX, SST, 5/16-18 UNC
6	104692	8	BOLT- CARR, CLIPPED HEAD,5/8-11 UNC X 2.00, STL, ZP
7	100149	8	NUT-HEX HD, FIN, STL, 5/8-11 UNC, ZP
8	106277	8	WSHR- POLY, .50 ID X 1.75 OD X .50 THK
9	105874	8	NUT- LOCK, SGL THD, 5/8-11, PALNUT
10	100147	8	WSHR- PL, A, STL, 5/8,11/16 ID X 1-3/4 OD X .134 THK, ZP
11	100148	8	WSHR- LOCK, HS, REG, STL, 5/8, ZP

SERVICE PARTS LIST

MODEL NO. - 570412

CREW CAB APPLICATION
USES THIS HOLE LOCATION

EXTENDED CAB APPLICATION
USES THIS HOLE LOCATION

LIVERNE LOGO SHOULD BE
TOWARD REAR OF VEHICLE

RIGHT HAND STEP
LEFT HAND STEP
(SOLD SEPARATELY)

SQUARE HEAD SCREWS
MUST BE INSTALLED IN
SLOT FROM END OF STEP

FRONT

LEFT HAND (DRIVERS SIDE)
SIDE ENTRY STEP ASSEMBLY

