

INSTALLATION INSTRUCTIONS AND PARTS LIST

MODEL: 583098, 583102, 583108, 583114, 583125, 584098, 584102, 584114, 584125 O-MEGA II 6" OVAL
STEPS
UNIVERSAL APPLICATION

1. READ INSTRUCTIONS COMPLETELY AND CHECK TO MAKE SURE THAT ALL REQUIRED PARTS (LISTED ON THE SERVICE PARTS LIST) ARE ON HAND BEFORE STARTING THE INSTALLATION.
2. FOLLOW THE INSTRUCTIONS INCLUDED WITH THE SPECIFIC BRACKET PACKAGE THAT YOU ARE USING, TO MOUNT THE BRACKETS TO YOUR VEHICLE.
3. BEFORE ATTACHING THE O-MEGA STEPS TO THE BRACKETS, PLACE THE STEP PADS (ITEM #2) ON TOP OF THE STEP PLATES. USE THE TABLE ON SHEET #2, AS A GUIDE TO POSITION THE STEP PAD FOR YOUR PARTICULAR VEHICLE. WHEN INSTALLING THE PADS ON THE STEPS, DRILL (5) 1/8" HOLE USING THE STEP PAD AS A GUIDE. ATTACH WITH (5) 8-18X1/2" TEK SCREWS (ITEM #6) PROVIDED. REPEAT FOR ALL STEP PADS. **(NOTE: DUE TO THE SHORTNESS OF SOME BOXES, MOUNT THE BOX STEP PAD FIRST, APPROXIMATELY 1/2" FROM THE END CAP AND THEN MOUNT THE MIDDLE STEP PAD ACCORDINGLY.)**
4. INSTALL THE REQUIRED NUMBER OF SQUARE HEAD BOLTS INTO THE DESIGNATED SLOTS IN THE BOTTOM OF THE STEP PLATES.
5. INSTALL THE END CAPS (ITEM #3) AS SHOWN IN *fig. 1*, TIGHTENING THE NUTS TO 5 LB FT.
6. POSITION THE O-MEGA STEP ON THE MOUNTING BRACKETS SO THAT THE SQUARE HEAD SCREWS (ITEM #4) ARE LOCATED IN THE SLOTS OF THE MOUNTING BRACKETS AND THE STEP IS CENTERED, FRONT TO REAR, ON THE VEHICLE. INSTALL 5/16" SERRATED FLANGE NUTS (ITEM #5) ON THE SQUARE HEAD SCREWS (ITEM #4) AND TIGHTEN TO 19 LB FT.

SERVICE PARTS LIST

ITEM	PART NO.	QTY	DESCRIPTION
1	553074	2	EXTRUSION-AL,95.0,OMEGA STP,SILVEER
1	553075	2	EXTRUSION-AL,99.0,OMEGA STP,SILVER
1	553076	2	EXTRUSION-AL,105.0,OMEGA STP,SILVER
1	553077	2	EXTRUSION-AL,111.0,OMEGA STP,SILVER
1	553078	2	EXTRUSION-AL,122.0,OMEGA STP,SILVER
1	553062	2	EXTRUSION-AL,95.0,OMEGA STP,BLACK
1	553063	2	EXTRUSION-AL,99.0,OMEGA STP,BLACK
1	553065	2	EXTRUSION-AL,111.0,OMEGA STP,BLACK
1	553066	2	EXTRUSION-AL,122.0,OMEGA STP,BLACK
2	107957	6	ALUM,STP-PAD,BLK,OMEGA-STEP
3	107956	4	CAP-END,PLSTC,2.95 X 6.70
4	106880	28	SCREW-SQ HD,5/16-18 X 1,MAGNIGUARD
5	102680	28	NUT-SERR FLG,HX,SST,WX,5/16-18
6	107958	30	SCREW-PPH,TEK,#8-18 X 1/2",SST,BZP



STEP PAD LOCATION GUIDE

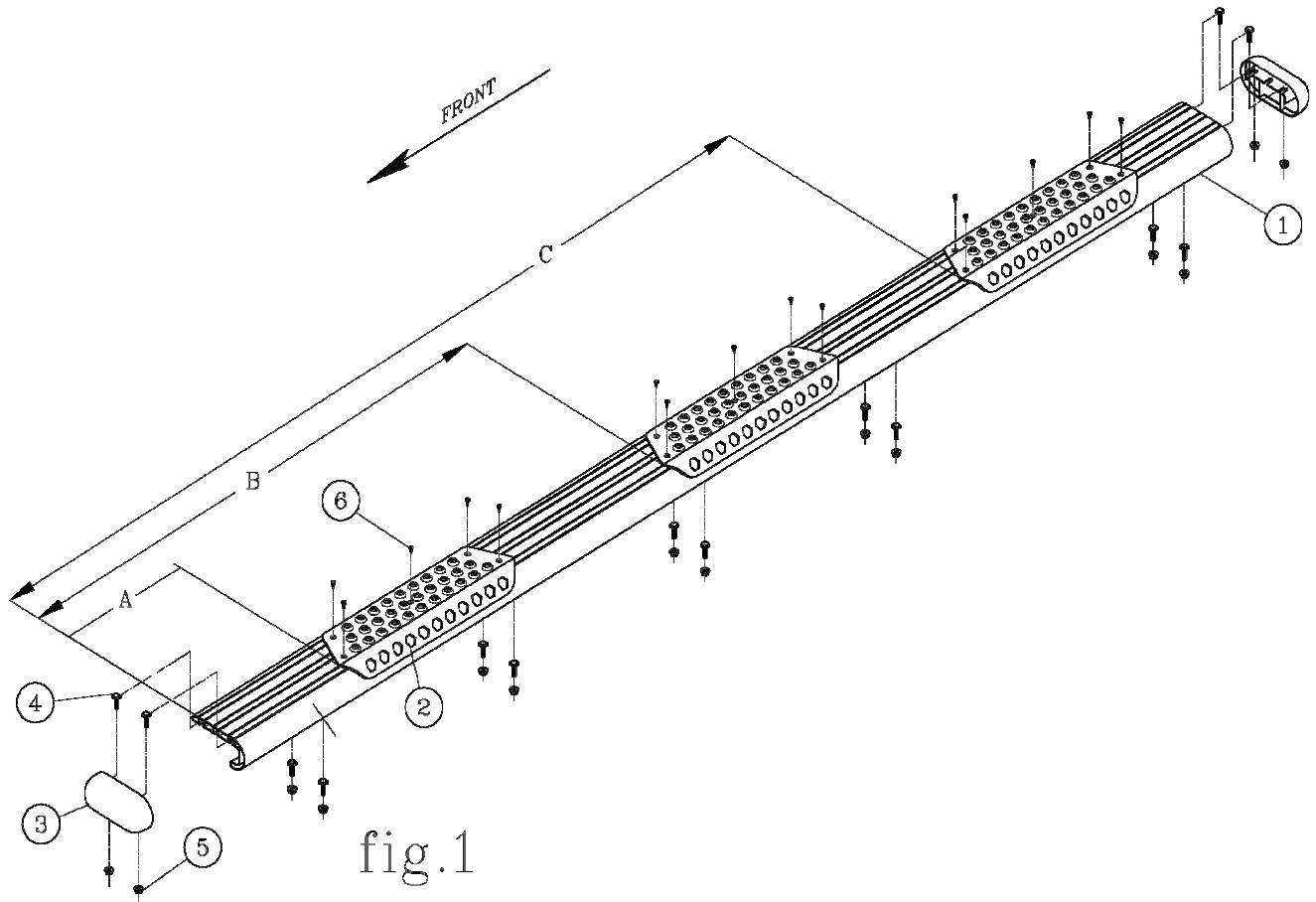

VEHICLE MODEL	PAD A	PAD B
SILVERADO/SIERRA DOUBLE CAB	14-3/4	46-3/4
SILVERADO/SIERRA EXTENDED CAB	14-3/4	41-3/4
SILVERADO/SIERRA CREW CAB	14-3/4	54-1/4
CHEVROLET EXPRESS VAN & GMC SAVANA VAN	7-1/2	N/A
RAM QUAD CAB	10-1/2	46
RAM CREW CAB	10-1/2	48
RAM MEGA CAB	10-1/2	52-1/16
FORD F150 SUPER CAB	18-1/4	46-1/4
FORD F150 SUPER CREW CAB	18-1/4	56-1/2
FORD F150 SUPER CREW CAB	18-1/4	56-1/2
FORD SUPER DUTY SUPER CAB	6-7/8	39-1/16
FORD SUPER DUTY CREW CAB	6-7/8	52-7/8
FORD	7-1/2	N/A

NOTE: THE ABOVE PAD LOCATIONS ARE ONLY SUGGESTIONS AND MAY BE PLACED AT THE PURCHASERS DISCRETION.

INSTALLATION INSTRUCTIONS AND PARTS LIST

APPLICATION: MODEL 570939/400939 W2W MEGA/GRIP STEP BRACKETS ON:
09-16 RAM 1500 PICKUPS



1. READ INSTRUCTIONS COMPLETELY AND CHECK TO MAKE SURE THAT ALL REQUIRED PARTS (LISTED ON SERVICE PARTS LIST) ARE ON HAND BEFORE STARTING THE INSTALLATION.
2. ASSEMBLE THE LOAD REACTION STUDS AND HARDWARE AS FOLLOWS.

NOTE: USE A 4" STUD (ITEM #19) FOR THE FRONT BRACKET AND A 3" STUD (ITEM #18) FOR THE REAR BRACKETS.

- 2.1. ON THE SHORT THREADED END OF THE LOAD REACTION STUD (ITEM #18, 19), INSTALL A 3/8" SERRATED FLANGE NUT (ITEM #17) BACKWARDS TO THE BOTTTOM OF THE THREAD. THEN INSTALL A 3/8" FLAT WASHER (ITEM #16) AND RUBBER "CUSHION" WASHER (ITEM # 15) TIGHT UP AGAINST THE SERRATED FLANGE NUT. (THE END OF THE STUD MUST BE RECESSED IN THE RUBBER WASHER APPROX. 3/16").
- 2.2. ON THE LONG THREADED END OF THE STUD, INSTALL A 3/8" SERRATED FLANGE NUT (ITEM # 17) BACKWARDS TO NEAR TO THE BOTTTOM OF THE THREADS
3. ATTACH THE LOAD REACTION STUD ASSEMBLIES TO THE MOUNTING BRACKETS AS SHOWN. INSERT THE STUD, FROM WHAT WILL BE THE INBOARD OR FRAME SIDE THRU THE LOWEST HOLE IN THE BENT FLANGE OF THE BRACKET THAT WILL ALLOW THE RUBBER WASHER TO SEAT FIRM AGAINST THE SIDE WALL OF THE FRAME. INSTALL A FLANGE NUT (ITEM #17) ON THE OUTBOARD END OF THE STUD (FINGER TIGHT ONLY).
4. ON THE RIGHT SIDE OF THE VEHICLE, REMOVE THE FACTORY FRONT, CENTER, AND REAR BODY MOUNT BOLTS (ONE SIDE OF THE VEHICLE AT A TIME), THESE WILL NOT BE REUSED. INSTALL THE MOUNTING BRACKETS PER THE FOLLOWING INSTRUCTIONS:
 - 4.1. USING A M12 – 110MM BOLT (ITEM #13) AND A 2.0" WASHER (ITEM #14) INSTALL THE FRONT MOUNTING BRACKET (ITEM #1, 2) TO THE FRONT BODY MOUNT AS SHOWN (LEAVE THESE FASTENERS FINGER TIGHT).
 - 4.2. USING A M12 – 110MM BOLT (ITEM #13) AND A 2.0" WASHER (ITEM #14) INSTALL THE CENTER MOUNTING BRACKET (ITEM #3, 4) TO THE CENTER BODY MOUNT AS SHOWN (LEAVE THESE FASTENERS FINGER TIGHT).
 - 4.3. IF THERE IS A CAST IRON DAMPENER ON THE REAR BODY MOUNT PLEASE REMOVE (THIS WILL NOT BE REUSED).
 - 4.4. USING A M12 – 110MM BOLT (ITEM #13) AND A 1/2" FLAT WASHER (ITEM #21) INSTALL THE REAR MOUNTING BRACKET (ITEM #5, 6) TO THE REAR BODY MOUNT AS SHOWN (LEAVE THESE FASTENERS FINGER TIGHT).
 - 4.5. ATTACH THE REAR OUTBOARD MOUNTING BRACKET (ITEM #7, 8) TO THE REAR INBOARD MOUNTING BRACKET (ITEM #5, 6), IN THE LOWER MOUNTING HOLES, USING THREE 3/8-16 X 1.0 SCREW, 3/8" FLAT WASHERS AND 3/8" FLANGE NUTS. (ITEMS #16, 17, 20)



(A LUCERNE Company)

1200 E. Birch St.

Brandon, SD 57005

552893 SHEET 1 OF 4 03JUN15

5. ATTACH THE MOUNTING BRACKETS TO THE BOX OF THE VEHICLE AS FOLLOWS:
 - 5.1 ATTACH THE INBOARD MOUNTING BRACKETS (ITEM #9, 10) TO THE FRAME AS SHOWN USING 1/2-13 X 1.00 HEX SCREW, 1/2" WASHER, AND 1/2-13 SERRATED FLANGE NUTS (ITEM #21, 22, 23). LEAVE THIS BRACKET LOOSE AT THIS TIME. **NOTE THAT THESE MOUNTING BRACKETS ARE NOT THE SAME FROM LEFT TO RIGHT.**
 - 5.2 ATTACH THE W2W SUPPORT BRACKET (ITEM #12) TO THE INBOARD MOUNTING BRACKET USING TWO 3/8-16X 1" HEX SCREWS, TWO 3/8" WASHERS, AND TWO 3/8-16 FLANGE NUTS (ITEMS #16, 17, 20) AND TO THE FRAME AS SHOWN USING A 1/2"-13 X 1" HEX SCREW, A 1/2" WASHER, AND A 1/2"-13 SERRATED FLANGE NUT (ITEMS #21, 22, 23). LEAVE THIS BRACKET LOOSE AT THIS TIME.
 - 5.1. INSTALL THE W2W OUTBOARD MOUNTING BRACKET (ITEM #11) TO THE INBOARD W2W BRACKET AS SHOWN USING TWO BLACK 5/16"-18 X 1" HEX SCREWS, TWO BLACK 5/16" WASHERS AND TWO BLACK 5/16"-18 FLANGE NUTS (ITEMS #24, 25, 26). LEAVE THIS BRACKET LOOSE AT THIS TIME
6. ATTACH THE STEP PLATE PER THE INSTRUCTIONS INCLUDED WITH YOUR STEP PLATE ASSEMBLY.
7. TIGHTEN ALL BOLTS AND NUTS ON THE REAR W2W BRACKET, TIGHTEN THE 1/2"-13 FLANGE NUTS TO 60 LB FT. TIGHTEN ALL REMAINING BODY MOUNT BOLTS.
8. POSITION THE LOAD REACTION STUD ASSY SO THAT THE RUBBER CUSHION IS SNUG UP AGAINST THE SIDE OF THE FRAME. TIGHTEN THE 3/8" FLANGE NUTS ON EITHER SIDE OF THE BRACKET TO 19LB. FT.



(A LUPERNE Company)

1200 E. Birch St.

Brandon, SD 57005

552893 SHEET 2 OF 4 03JUN15

SERVICE PARTS LIST

ITEM	PART NO.	QTY	DESCRIPTION
1	552850	1	BRKT-MTG, MS, FRONT, LH, BODY MOUNT
1	552862	1	BRKT-MTG, GRIP, FRONT, LH, BODY MOUNT
2	552851	1	BRKT-MTG, MS, FRONT, RH, BODY MOUNT
2	552863	1	BRKT-MTG, GRIP, FRONT, RH, BODY MOUNT
3	552852	1	BRKT-MTG, MS, CENTER, LH, BODY MOUNT
3	552864	1	BRKT-MTG, GRIP CENTER, LH, BODY MOUNT
4	552853	1	BRKT-MTG, MS, CENTER, RH, BODY MOUNT
4	552865	1	BRKT-MTG, GRIP, CENTER, RH, BODY MOUNT
5	552854	1	BRKT-MTG, REAR, LH, INBOARD, BODY MOUNT
6	552855	1	BRKT-MTG, REAR, RH, INBOARD, BODY MOUNT
7	552856	1	BRKT-MTG, MS, REAR, LH, OUTBOARD
7	552868	1	BRKT-MTG, GRIP, REAR, LH, OUTBOARD
8	552857	1	BRKT-MTG, MS, REAR, RH, OUTBOARD
8	552869	1	BRKT-MTG, GRIP, REAR, RH, OUTBOARD
9	551693	1	BRKT-MTG, MS, W2W, LH, INBOARD
9	551881	1	BRKT-MTG, GRIP, W2W, LH, INBOARD
10	551694	1	BRKT-MTG, MS, W2W, RH, INBOARD
10	551882	1	BRKT-MTG, GRIP, W2W, RH, INBOARD
11	551721	2	BRKT-MTG, MS, W2W, OUTBOARD
11	552125	2	BRKT-MTG, GRIP, W2W, OUTBOARD
12	552875	2	BRKT-MTG, W2W, SUPPORT
13	103444	6	SCREW-HEX HEAD, M12 - 1.75 X 110MM, ZP
14	105909	4	WSHR-FLAT, 2.0 X .509 X .179, ZP
15	102592	6	WSHR, RUBBER, .354 ID X 1.00 OD X .75 THK
16	100062	16	WSHR, FLAT, 3/8", .438 ID X 1.00 OD X .083" THK
17	100181	28	NUT, SERR FLG, HEX, 3/8-16 UNC, ZP
18	104697	4	STUD, STL, 3/8-16 X 3.00", ZP
19	104686	2	STUD, -DBL ENDED, STL, 3/8-16 X 4.00", ZP
20	100040	10	SCR-HEX HD, 3/8-16 X 1.0" UNC, ZP
21	100118	6	WASHER, FLAT, 1/2" ZP
22	100085	4	SCR-HEX HD, 1/2"-13 X 1", ZP
23	100123	4	NUT-HEX, FLG, 1/2"-13
24	106996	4	NUT-SERR FLG, SST, 5/16"-18, BZP
25	106997	4	SCR-HEX HD, 5/16"-18 X 1.00", BZP
26	106998	4	WASHER, SST, 5/16", BZP



(A LIVERNE Company)

1200 E. Birch St.

Brandon, SD 57005

552893 SHEET 3 OF 4 03JUN15

FIG. 1 CREW/QUAD CAB

SERVICE PARTS LIST

MODEL NO. - 570939/400939

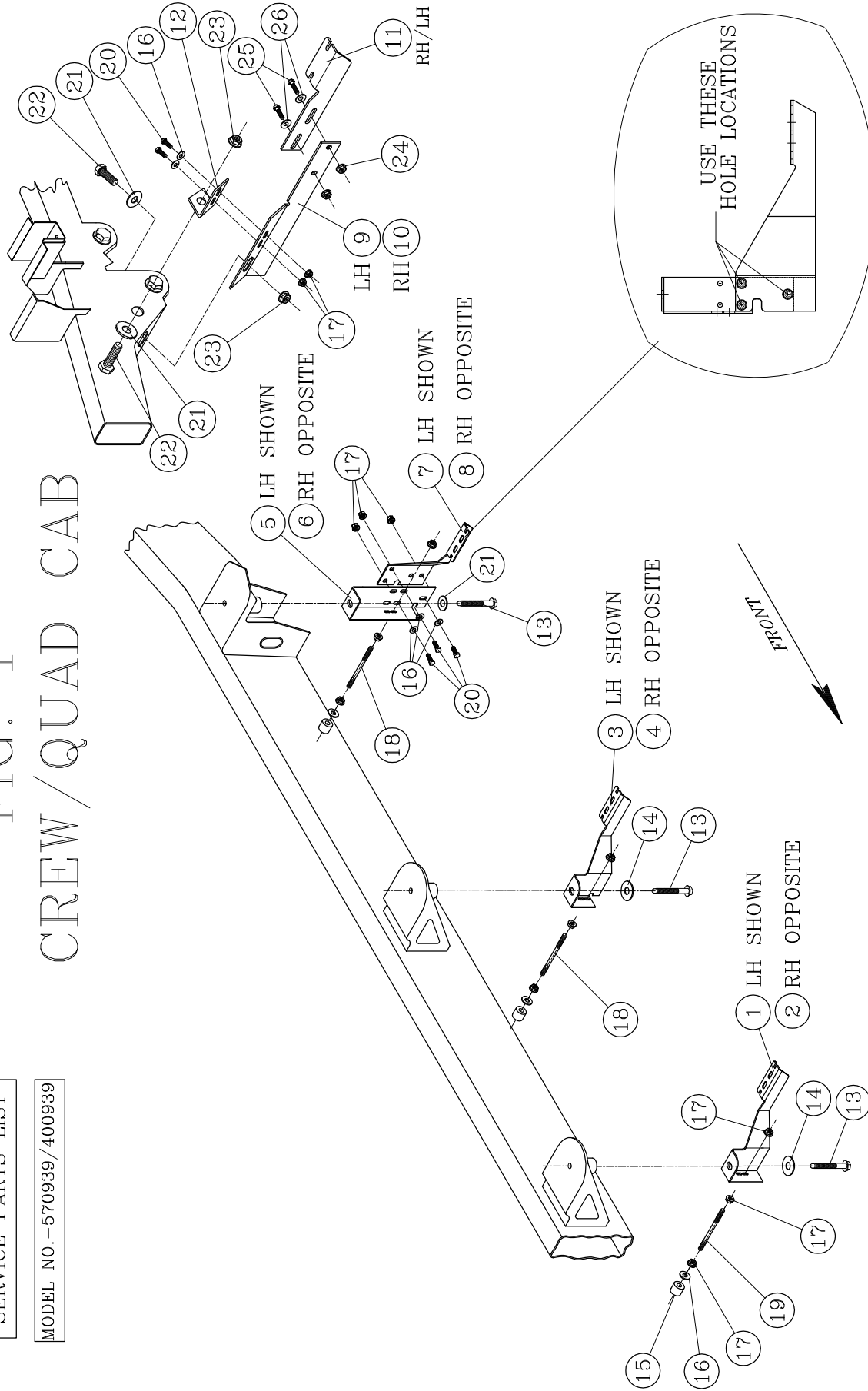

LEFT (DRIVER) SIDE SHOWN

LEFT (DRIVER) SIDE SHOWN
-RIGHT (PASSENGER) SIDE OPPOSITE-