

INSTALLATION INSTRUCTIONS AND PARTS LIST

MODEL: 583098, 583102, 583108, 583114, 583125, 584098, 584102, 584114, 584125 O-MEGA II 6" OVAL
STEPS
UNIVERSAL APPLICATION

1. READ INSTRUCTIONS COMPLETELY AND CHECK TO MAKE SURE THAT ALL REQUIRED PARTS (LISTED ON THE SERVICE PARTS LIST) ARE ON HAND BEFORE STARTING THE INSTALLATION.
2. FOLLOW THE INSTRUCTIONS INCLUDED WITH THE SPECIFIC BRACKET PACKAGE THAT YOU ARE USING, TO MOUNT THE BRACKETS TO YOUR VEHICLE.
3. BEFORE ATTACHING THE O-MEGA STEPS TO THE BRACKETS, PLACE THE STEP PADS (ITEM #2) ON TOP OF THE STEP PLATES. USE THE TABLE ON SHEET #2, AS A GUIDE TO POSITION THE STEP PAD FOR YOUR PARTICULAR VEHICLE. WHEN INSTALLING THE PADS ON THE STEPS, DRILL (5) 1/8" HOLE USING THE STEP PAD AS A GUIDE. ATTACH WITH (5) 8-18X1/2" TEK SCREWS (ITEM #6) PROVIDED. REPEAT FOR ALL STEP PADS. **(NOTE: DUE TO THE SHORTNESS OF SOME BOXES, MOUNT THE BOX STEP PAD FIRST, APPROXIMATELY 1/2" FROM THE END CAP AND THEN MOUNT THE MIDDLE STEP PAD ACCORDINGLY.)**
4. INSTALL THE REQUIRED NUMBER OF SQUARE HEAD BOLTS INTO THE DESIGNATED SLOTS IN THE BOTTOM OF THE STEP PLATES.
5. INSTALL THE END CAPS (ITEM #3) AS SHOWN IN *fig. 1*, TIGHTENING THE NUTS TO 5 LB FT.
6. POSITION THE O-MEGA STEP ON THE MOUNTING BRACKETS SO THAT THE SQUARE HEAD SCREWS (ITEM #4) ARE LOCATED IN THE SLOTS OF THE MOUNTING BRACKETS AND THE STEP IS CENTERED, FRONT TO REAR, ON THE VEHICLE. INSTALL 5/16" SERRATED FLANGE NUTS (ITEM #5) ON THE SQUARE HEAD SCREWS (ITEM #4) AND TIGHTEN TO 19 LB FT.

SERVICE PARTS LIST

ITEM	PART NO.	QTY	DESCRIPTION
1	553074	2	EXTRUSION-AL,95.0,OMEGA STP,SILVEER
1	553075	2	EXTRUSION-AL,99.0,OMEGA STP,SILVER
1	553076	2	EXTRUSION-AL,105.0,OMEGA STP,SILVER
1	553077	2	EXTRUSION-AL,111.0,OMEGA STP,SILVER
1	553078	2	EXTRUSION-AL,122.0,OMEGA STP,SILVER
1	553062	2	EXTRUSION-AL,95.0,OMEGA STP,BLACK
1	553063	2	EXTRUSION-AL,99.0,OMEGA STP,BLACK
1	553065	2	EXTRUSION-AL,111.0,OMEGA STP,BLACK
1	553066	2	EXTRUSION-AL,122.0,OMEGA STP,BLACK
2	107957	6	ALUM,STP-PAD,BLK,OMEGA-STEP
3	107956	4	CAP-END,PLSTC,2.95 X 6.70
4	106880	28	SCREW-SQ HD,5/16-18 X 1,MAGNIGUARD
5	102680	28	NUT-SERR FLG,HX,SST,WX,5/16-18
6	107958	30	SCREW-PPH,TEK,#8-18 X 1/2",SST,BZP



STEP PAD LOCATION GUIDE

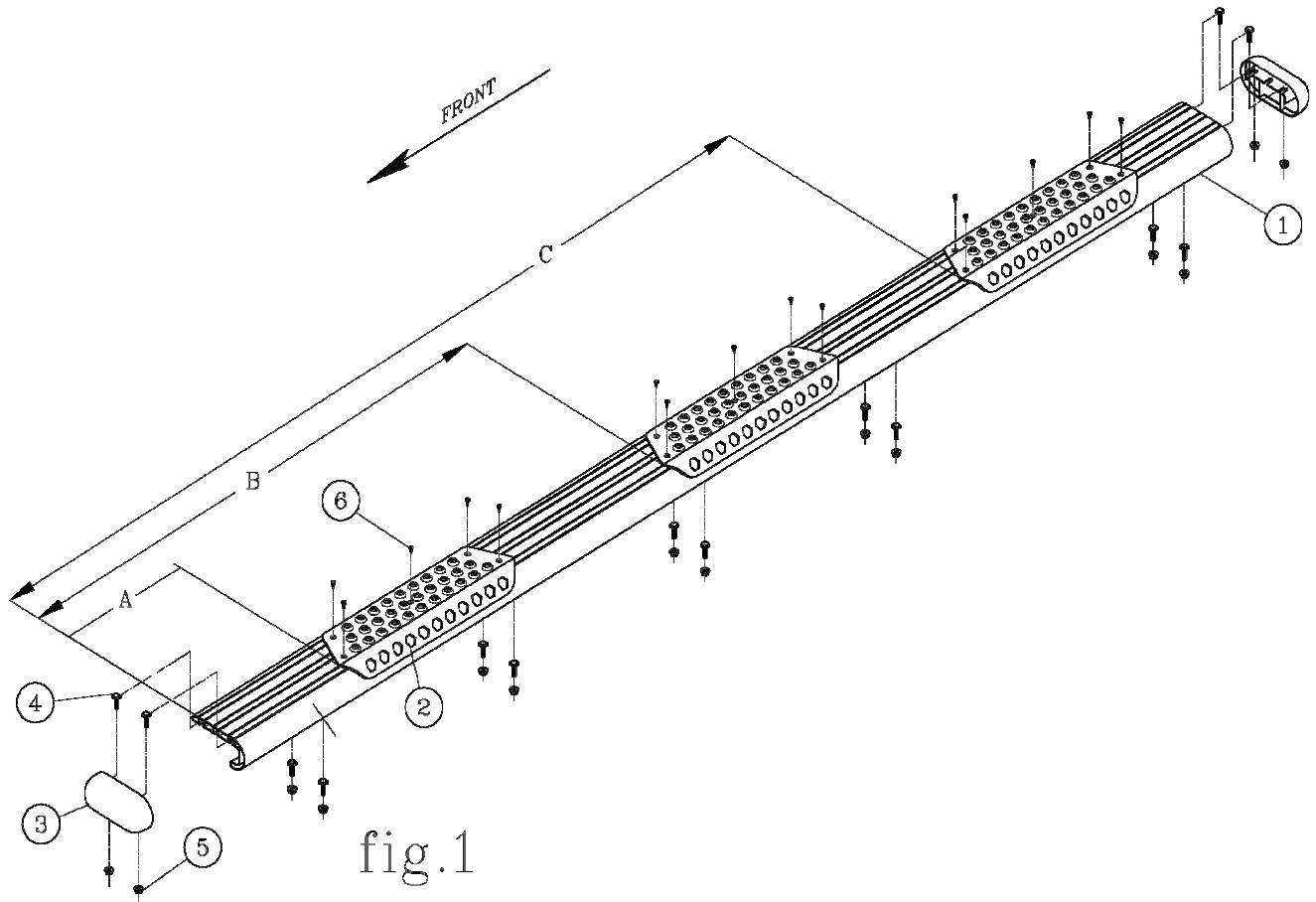

VEHICLE MODEL	PAD A	PAD B
SILVERADO/SIERRA DOUBLE CAB	14-3/4	46-3/4
SILVERADO/SIERRA EXTENDED CAB	14-3/4	41-3/4
SILVERADO/SIERRA CREW CAB	14-3/4	54-1/4
CHEVROLET EXPRESS VAN & GMC SAVANA VAN	7-1/2	N/A
RAM QUAD CAB	10-1/2	46
RAM CREW CAB	10-1/2	48
RAM MEGA CAB	10-1/2	52-1/16
FORD F150 SUPER CAB	18-1/4	46-1/4
FORD F150 SUPER CREW CAB	18-1/4	56-1/2
FORD F150 SUPER CREW CAB	18-1/4	56-1/2
FORD SUPER DUTY SUPER CAB	6-7/8	39-1/16
FORD SUPER DUTY CREW CAB	6-7/8	52-7/8
FORD	7-1/2	N/A

NOTE: THE ABOVE PAD LOCATIONS ARE ONLY SUGGESTIONS AND MAY BE PLACED AT THE PURCHASERS DISCRETION.

INSTALLATION INSTRUCTIONS AND PARTS LIST

APPLICATION: MODEL **571529** W2W MEGA STEP/SES BRACKETS ON:
2015+ FORD F150 PICKUPS
ROCKER PANEL MOUNT APPLICATION



NO DRILL APPLICATION

1. READ INSTRUCTIONS COMPLETELY AND CHECK TO MAKE SURE THAT ALL REQUIRED PARTS (LISTED ON SERVICE PARTS LIST) ARE ON HAND BEFORE STARTING THE INSTALLATION.

NOTE: IF INSTALLING ON A REGULAR CAB OR SUPER CAB PICKUP THERE WILL BE TWO UNUSED BRACKETS.

2. ON THE LEFT SIDE OF THE VEHICLE INSTALL TWO 1.5" ISOLATOR WASHERS (ITEM #3) THE STEP MOUNTING BRACKET (ITEM #2) AND TWO M8-1.25 FLANGE NUTS (ITEM #4) ON THE FACTORY PROVIDED STUDS ON THE INSIDE OF THE ROCKER PANEL AS SHOWN IN FIGURE 1.
3. REPEAT STEP 2 FOR THE REMAINING BRACKETS.
4. CHECK THAT ALL BRACKETS ARE LEVEL AND TIGHTEN ALL FLANGE NUTS.
5. REMOVE THE CABLE GUIDE BRACKET FROM THE LEAF SPRING SHACKLE. **NOTE: THIS IS ONLY NECESSARY ON THE LEFT (DRIVERS) SIDE OF THE VEHICLE. NOTE: THE CABLE GUIDE BRACKET WILL NO LONGER BE NEEDED AND MAY BE REMOVED IF DESIRED.**
6. REMOVE THE NUT ON THE SPRING SHACKLE BOLT AND INSTALL THE REAR INBOARD BRACKET (ITEM #8). AS SHOWN IN FIGURE 2. MAKE SURE THE INBOARD BRACKET IS VERTICAL AND TIGHTEN TO 80 LB-FT.
7. USING TWO 5/16-18 X 1" BOLTS (ITEM #6) TWO 5/16 FLAT WASHERS (ITEM #7) AND TWO 5/16-18 FLANGE NUTS (ITEM #5) INSTALL THE OUTBOARD BRACKET (ITEM #10) AS SHOWN IN FIGURE 2. **NOTE: LEAVE THIS BRACKET LOOSE AT THIS TIME.**
8. ATTACH THE STEP BOARD TO THE MOUNTING BRACKETS AS DESCRIBED IN THE INSTRUCTION SHEET INCLUDED WITH YOUR STEP BOARD ASSEMBLY.
9. ADJUST THE REAR OUTBOARD BRACKET FOR YOUR STEP ASSEMBLY AND TIGHTEN THE BOLTS SECURING THE OUTBOARD BRACKET TO THE INBOARD BRACKET.
10. USING A 5/16-18 X 1" BOLT (ITEM #6) A 5/16" FLAT WASHER (ITEM #7) AND A 5/16-18 FLANGE NUT (ITEM #5) INSTALL THE REAR CLAMP BRACKET (ITEM #11) OVER THE CABLES FROM STEP 5 ONTO THE REAR INBOARD BRACKET.
11. REPEAT STEPS 2 – 9 FOR THE RIGHT SIDE OF THE VEHICLE.



(A LIVERNE Company)

1200 E. Birch St.

Brandon, SD 57005

552824 SHEET 1 OF 3 22JAN15

SERVICE PARTS LIST

ITEM	PART NO.	QTY	DESCRIPTION
1		1	STEP ASSY, MEGA STEP / O-MEGA STEP / SES
2	552643	6	BRACKET-MTG, MEGA STEP/O-MEGA STEP/SES, 571523
3	108442	12	WASHER – NYLON, .36” X 1.5” X .032” BLACK
4	105859	12	NUT- FLANGE, M8-1.25, ZP
5	106996	5	NUT-FLANGE, 5/16-18, BZP
6	106997	5	BOLT- 5/16-18 X 1.00” BZP
7	106998	5	WASHER-FLAT, 5/16” BZP
8	552752	1	BRKT-MTG, REAR, INBOARD, LH
9	552753	1	BRKT-MTG, REAR, INBOARD, RH
10	551721	2	BRKT,STEP, REAR, OUTBOARD
11	552754	1	BRKT-CLAMP, REAR, LH



1200 E. Birch St.

Brandon, SD 57005

552824 SHEET 2 OF 3 22JAN15

SERVICE PARTS LIST

MODEL NO. - 571529

2015 FORD F150 WZW

- FIG 2 -

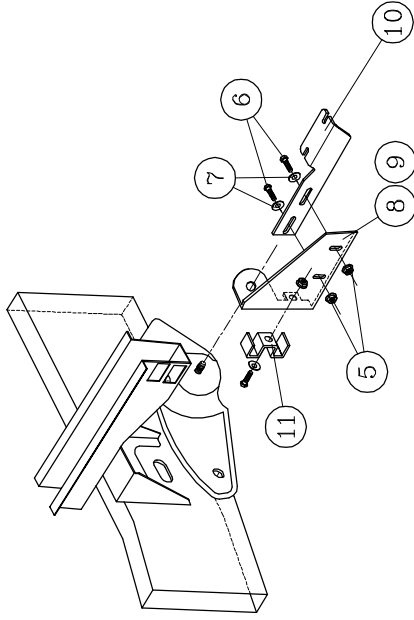

- REAR BRACKET ASSEMBLY -

NOTE: SUPERCREW CONFIGURATION SHOWN

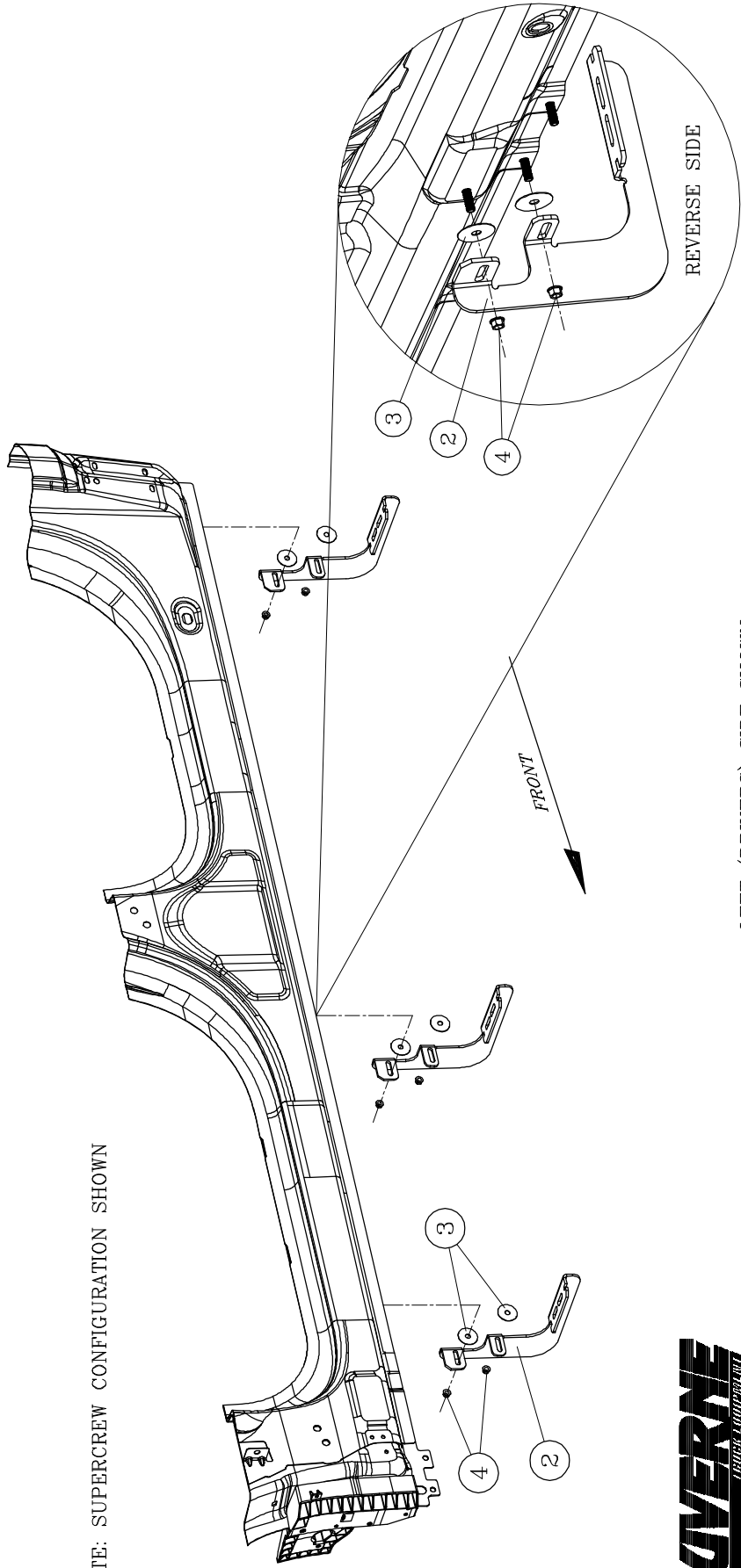

- LEFT (DRIVERS) SIDE SHOWN -

- RIGHT (PASSENGER) SIDE OPPOSITE -

LOVERNE
A LOVERNE COMPANY
FISHER FLOOR PILE LTD

1200 E. 20th St.
Bismarck, ND 58105