

INSTALLATION INSTRUCTIONS AND PARTS LIST

MODEL 585054, 585060, 586054 O-MEGA STEPS

1. READ INSTRUCTIONS COMPLETELY AND CHECK TO MAKE SURE THAT ALL REQUIRED PARTS (LISTED ON THE SERVICE PARTS LIST) ARE ON HAND BEFORE STARTING THE INSTALLATION.
2. FOLLOW THE INSTRUCTIONS INCLUDED WITH THE SPECIFIC BRACKET PACKAGE THAT YOU ARE USING, TO MOUNT THE BRACKETS TO YOUR VEHICLE.
3. BEFORE ATTACHING THE O-MEGA STEPS TO THE BRACKETS, MOUNT THE STEP PADS (ITEM #2) TO THE STEP PLATES USING THE 1/2" TEK SCREWS (ITEM #6) PROVIDED. USE THE TABLE ON SHEET #2, AS A GUIDE TO POSITION THE STEP PAD FOR YOUR PARTICULAR VEHICLE. WHEN INSTALLING THE PADS ON THE STEPS, DRILL AND INSTALL THE TWO CENTER SCREWS FIRST. IF INSTALLING THE PADS WHEN THE TEMPERATURE IS AROUND 70° F., MAKE SURE THE SCREWS IN THE END SLOTTED HOLES ARE IN THE MIDDLE OF THE SLOT. WHEN TURNING IN THE SCREWS, TURN THEM IN SNUG THEN BACK OFF A ¼ TURN. PLASTIC WILL EXPAND WHEN IT IS HOT AND CONTRACT WHEN IT GETS COLD AND THE SLOT WILL ALLOW THIS TO HAPPEN WITHOUT RISING UP BETWEEN THE SCREWS.
4. INSTALL THE REQUIRED NUMBER OF SQUARE HEAD BOLTS INTO THE DESIGNATED SLOTS IN THE BOTTOM OF THE STEP PLATES.
5. INSTALL THE END CAPS (ITEM #3) AS SHOWN IN *fig. 1* SNUG UP THE NUTS. BE CAREFUL NOT TO DEFORM THE PLASTIC
6. POSITION THE O-MEGA STEP ON THE MOUNTING BRACKETS SO THAT THE SQUARE HEAD SCREWS (ITEM #4) ARE LOCATED IN THE SLOTS OF THE MOUNTING BRACKETS AND THE STEP IS CENTERED, FRONT TO REAR, ON THE VEHICLE. INSTALL 5/16" SERRATED FLANGE NUTS (ITEM #5) ON THE SQUARE HEAD SCREWS (ITEM #4) AND TIGHTEN TO 19 LB FT.

SERVICE PARTS LIST

ITEM	PART NO.	QTY	DESCRIPTION
1	107959	2	EXTRUSION-AL,51.0,OMEGA STP,585054
1	107960	2	EXTRUSION-AL,57.0,OMEGA STP,585060
1	109985	2	EXTRUSION-AL,51.0,OMEGA STP,586054BLK
2	107957	4	PAD-STEP PLATE, 4.50 X 20.00
3	107956	4	CAP-END,PLSTC,2.95 X 6.70
4	106880	20	SCREW-SQ HD,5/16-18 X 1,MAGNIGUARD
5	102680	20	NUT-SERR FLG,HX,SST,WX,5/16-18
6	107958	24	SCREW-PPH,TEK,#8-18 X 1/2",SST,BZP



1200 E. Birch St.

Brandon, SD 57005

REVISED 29JAN16 LVL D
REVISED 14SEP11 LVL C
REVISED 23JUN11 LVL B
REVISED 25APR08 LVL A
551776 SHEET 1 OF 2 09NOV07

STEP PAD LOCATION GUIDE

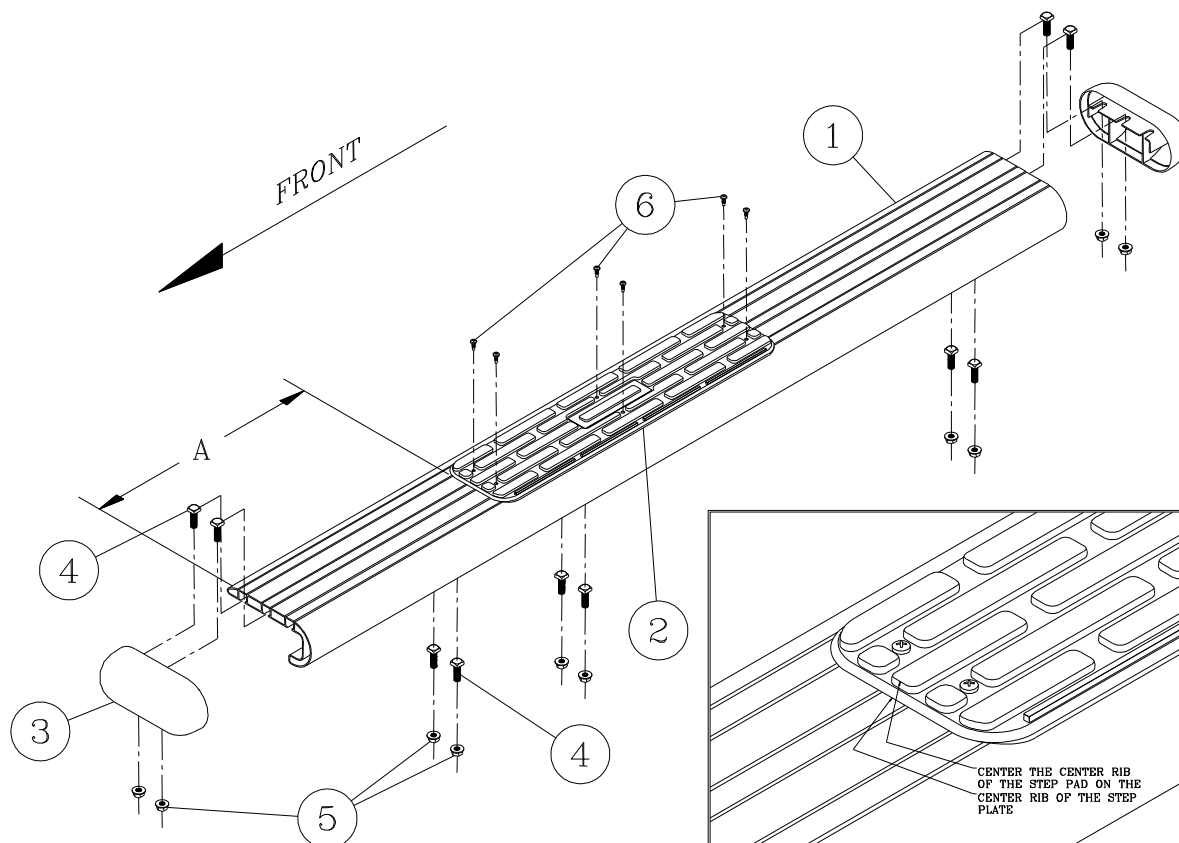

Fig. 1

VEHICLE MODEL	PAD A	PAD B
SILVERADO/SIERRA REGULAR CAB	14-3/4	N/A
DODGE RAM REGULAR CAB	10-1/2	N/A
FORD F150 REGULAR CAB	18-1/4	N/A
FORD SUPER DUTY REGULAR CAB	6-7/8	N/A
TUNDRA REGULAR CAB	6-1/2	N/A
TOYOTA FJ CRUSIER	6-1/2	N/A
FORD ESCAPE	5-1/2	35-1/2

NOTE: THE ABOVE PAD LOCATIONS ARE ONLY SUGGESTIONS AND MAY BE PLACED AT THE PURCHASERS DISCRETION. (THE 2008-2012 FORD ESCAPE WILL USE 2 PADS PER SIDE ON THE 585060 BOARDS).

LIVERNE

TRUCK EQUIPMENT

(A LIVERNE Company)

1200 E. Birch St.

Brandon, SD 57005

REVISED 29JAN16 LVL D
 REVISED 14SEP11 LVL C
 REVISED 23JUN11 LVL B
 REVISED 25APR08 LVL A
 551776 SHEET 2 OF 2 09NOV07

INSTALLATION INSTRUCTIONS AND PARTS LIST

VEHICLE APPLICATION: MODEL 570711 MEGA STEPS ON:
2007 GM SILVERADO & SIERRA REGULAR CAB PICKUPS



1. **READ INSTRUCTIONS COMPLETELY AND CHECK TO MAKE SURE THAT ALL REQUIRED PARTS (LISTED ON THE SERVICE PARTS LIST) ARE ON HAND BEFORE STARTING THE INSTALLATION.**
2. ATTACH THE MOUNTING BRACKETS TO THE VEHICLE AS FOLLOWS:
 - 2.1 INSERT 5/16" MULTI-THREAD U-NUT (ITEM #7) INTO THE UPPER HOLES IN THE ROCKER PANEL (SEE FIG. 1).
 - 2.2 ATTACH THE TOP OF THE MOUNTING BRACKETS (ITEM #2) TO THE VEHICLE WITH 5/16-18 X 1.0 SCREW AND FLAT WASHER (ITEMS #5&6). HAND TIGHTEN ONLY.
 - 2.3 INSERT A NYLON WASHER (ITEM #10) BETWEEN THE TOP OF THE MOUNTING BRACKET AND THE BOTTOM OF THE ROCKER PANEL AND INSTALL THE BLACK M8-1.25 SCREW, NUT, AND WASHER AND PINCH WELD SUPPORT (ITEM#3, 4, 5 & 11) AS SHOWN. TIGHTEN BRACKET FASTENERS TO 19 LB FT.
3. PREPARE THE MEGA STEP PLATE FOR MOUNTING BY INSERTING TWO (2) 5/16" SQUARE HEAD SCREWS (ITEM #9) IN THE CENTER SLOT ON THE UNDER SIDE OF THE STEP.
4. POSITIONS THE MEGA STEP ON THE MOUNTING BRACKETS SO THAT THE SQUARE HEAD SCREWS ARE LOCATED IN THE SLOTS OF THE MOUNTING BRACKETS AND THE STEP IS CENTERED, FRONT TO REAR, ON THE VEHICLE. INSTALL 5/16" SERRATED FLANGE NUTS (ITEM #8) ON THE SQUARE HEAD SCREWS AND TIGHTEN TO 19 LB FT.

SERVICE PARTS LIST

ITEM	PART NO.	QTY	DESCRIPTION
1	575054	1	STEP ASSY- 54.00"
2	551746	4	MOUNTING BRACKET, BLK, MEGA STEP
3	105859	4	M8-1.25 FLANGED NUT ZP
4	100180	4	M8 X 30 X1.25 SCR,SST,BZP
5	102734	8	5/16" STD FLAT WASHER SST
6	100647	4	5/16" X 1.00" SCR ZP
7	105541	4	MULTI THREAD U-NUT 5/16 -18
8	102680	8	NUT-SERRATED FLANGE, HEX, SST, 5/16-18 UNC
9	106880	4	SCREW-SQUARE HD,5/16-18UNC X 1.00"
10	107182	4	WASHER-SPCR,NYLON,BLK,.312 ID X 1.24OD X .25 THK
11	551666	4	BRKT-MTG,PINCH WELD SUPPORT

LIVERNE
ISO9001 QS9000 CERTIFIED TRUCK
EQUIPMENT
1200 Birch Street
Brandon, SD 57005
INC.

551748 SHEET 1 28FEB07
REVISION A 20OCT08

SERVICE PARTS LIST

MODEL NO. -570711

LUVERNE LOGO SHOULD BE TOWARD REAR OF VEHICLE

RIGHT HAND STEP
LEFT HAND STEP

1

INSTALL (2) LONG PALNUTS PER SIDE

REMOVE (2) PLASTIC BODY PLUGS PER SIDE

7

3

9

6

5

2

10

5

4

8

11

FRONT

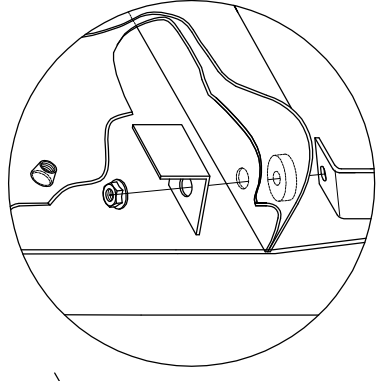

PINCH WELD SUPPORT ASSEMBLY

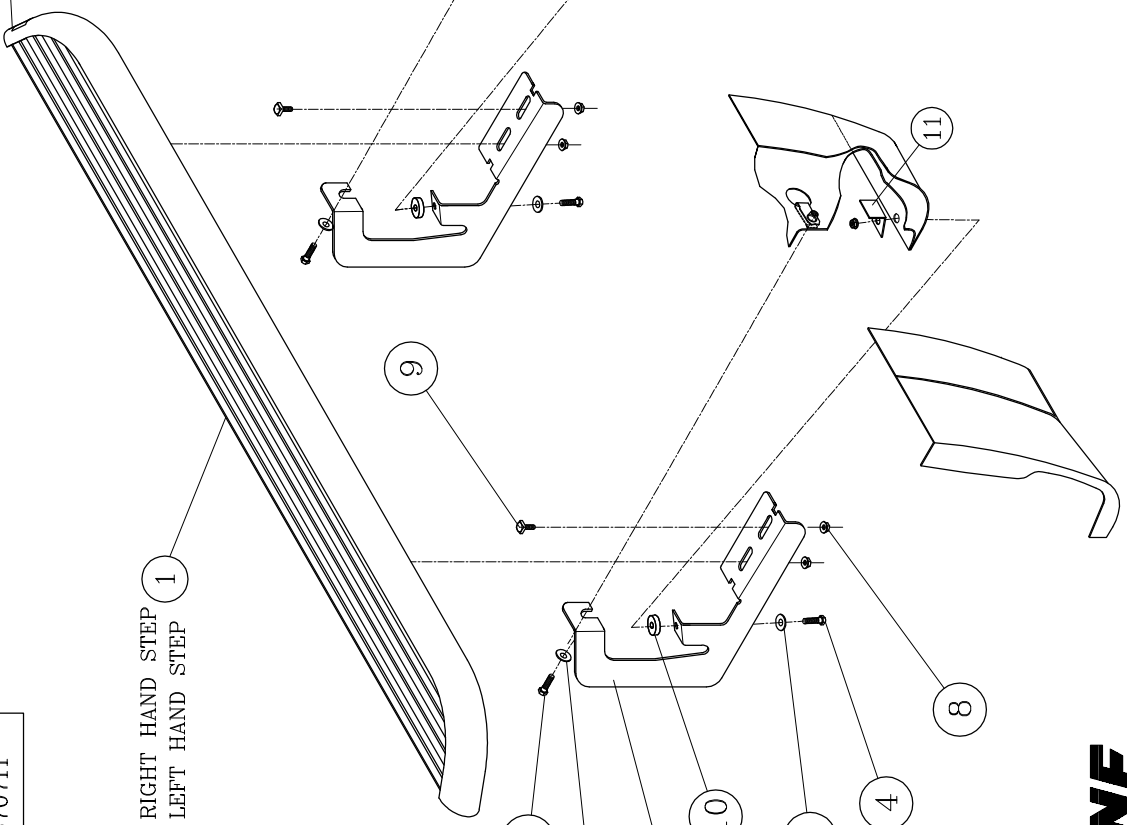

551748 SHEET 2 28FEB07
REVISION A 20OCT08

LEFT (DRIVER) SIDE SHOWN
-RIGHT (PASSENGER) SIDE OPPOSITE-

