

INSTALLATION INSTRUCTIONS AND PARTS LIST

MODEL 585054, 585060, 586054 O-MEGA STEPS

1. READ INSTRUCTIONS COMPLETELY AND CHECK TO MAKE SURE THAT ALL REQUIRED PARTS (LISTED ON THE SERVICE PARTS LIST) ARE ON HAND BEFORE STARTING THE INSTALLATION.
2. FOLLOW THE INSTRUCTIONS INCLUDED WITH THE SPECIFIC BRACKET PACKAGE THAT YOU ARE USING, TO MOUNT THE BRACKETS TO YOUR VEHICLE.
3. BEFORE ATTACHING THE O-MEGA STEPS TO THE BRACKETS, MOUNT THE STEP PADS (ITEM #2) TO THE STEP PLATES USING THE 1/2" TEK SCREWS (ITEM #6) PROVIDED. USE THE TABLE ON SHEET #2, AS A GUIDE TO POSITION THE STEP PAD FOR YOUR PARTICULAR VEHICLE. WHEN INSTALLING THE PADS ON THE STEPS, DRILL AND INSTALL THE TWO CENTER SCREWS FIRST. IF INSTALLING THE PADS WHEN THE TEMPERATURE IS AROUND 70° F., MAKE SURE THE SCREWS IN THE END SLOTTED HOLES ARE IN THE MIDDLE OF THE SLOT. WHEN TURNING IN THE SCREWS, TURN THEM IN SNUG THEN BACK OFF A ¼ TURN. PLASTIC WILL EXPAND WHEN IT IS HOT AND CONTRACT WHEN IT GETS COLD AND THE SLOT WILL ALLOW THIS TO HAPPEN WITHOUT RISING UP BETWEEN THE SCREWS.
4. INSTALL THE REQUIRED NUMBER OF SQUARE HEAD BOLTS INTO THE DESIGNATED SLOTS IN THE BOTTOM OF THE STEP PLATES.
5. INSTALL THE END CAPS (ITEM #3) AS SHOWN IN *fig. 1* SNUG UP THE NUTS. BE CAREFUL NOT TO DEFORM THE PLASTIC
6. POSITION THE O-MEGA STEP ON THE MOUNTING BRACKETS SO THAT THE SQUARE HEAD SCREWS (ITEM #4) ARE LOCATED IN THE SLOTS OF THE MOUNTING BRACKETS AND THE STEP IS CENTERED, FRONT TO REAR, ON THE VEHICLE. INSTALL 5/16" SERRATED FLANGE NUTS (ITEM #5) ON THE SQUARE HEAD SCREWS (ITEM #4) AND TIGHTEN TO 19 LB FT.

SERVICE PARTS LIST

ITEM	PART NO.	QTY	DESCRIPTION
1	107959	2	EXTRUSION-AL,51.0,OMEGA STP,585054
1	107960	2	EXTRUSION-AL,57.0,OMEGA STP,585060
1	109985	2	EXTRUSION-AL,51.0,OMEGA STP,586054BLK
2	107957	4	PAD-STEP PLATE, 4.50 X 20.00
3	107956	4	CAP-END,PLSTC,2.95 X 6.70
4	106880	20	SCREW-SQ HD,5/16-18 X 1,MAGNIGUARD
5	102680	20	NUT-SERR FLG,HX,SST,WX,5/16-18
6	107958	24	SCREW-PPH,TEK,#8-18 X 1/2",SST,BZP



1200 E. Birch St.

Brandon, SD 57005

REVISED 29JAN16 LVL D
REVISED 14SEP11 LVL C
REVISED 23JUN11 LVL B
REVISED 25APR08 LVL A
551776 SHEET 1 OF 2 09NOV07

STEP PAD LOCATION GUIDE

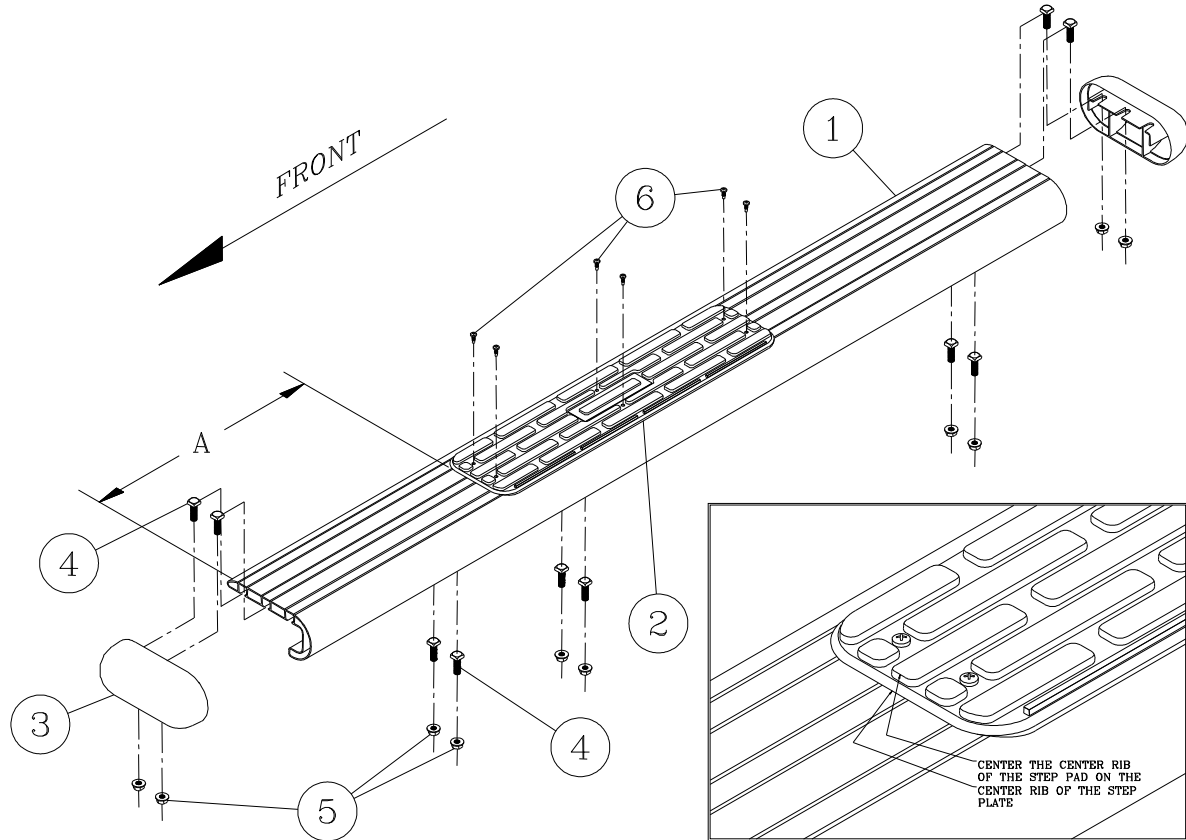

Fig. 1

VEHICLE MODEL	PAD A	PAD B
SILVERADO/SIERRA REGULAR CAB	14-3/4	N/A
DODGE RAM REGULAR CAB	10-1/2	N/A
FORD F150 REGULAR CAB	18-1/4	N/A
FORD SUPER DUTY REGULAR CAB	6-7/8	N/A
TUNDRA REGULAR CAB	6-1/2	N/A
TOYOTA FJ CRUSIER	6-1/2	N/A
FORD ESCAPE	5-1/2	35-1/2

NOTE: THE ABOVE PAD LOCATIONS ARE ONLY SUGGESTIONS AND MAY BE PLACED AT THE PURCHASERS DISCRETION. (THE 2008-2012 FORD ESCAPE WILL USE 2 PADS PER SIDE ON THE 585060 BOARDS).



(A LUVERNE Company)

1200 E. Birch St.

Brandon, SD 57005

REVISED 29JAN16 LVL D
 REVISED 14SEP11 LVL C
 REVISED 23JUN11 LVL B
 REVISED 25APR08 LVL A
 551776 SHEET 2 OF 2 09NOV07

INSTALLATION INSTRUCTIONS AND PARTS LIST

MODEL 579921 MEGA STEPS BRACKETS: 1999 AND NEWER FORD SUPER DUTY REGULAR CAB PICKUPS



1. READ INSTRUCTIONS COMPLETELY AND CHECK TO MAKE SURE THAT ALL REQUIRED PARTS (LISTED ON SERVICE PARTS LIST) ARE ON HAND BEFORE STARTING THE INSTALLATION.
2. EXISTING MOUNTING HOLE PATTERNS ARE LOCATED ON THE PINCH WELD AND INTERIOR WALL OF THE ROCKER PANEL. THESE MOUNTING HOLE PATTERNS MUST BE USED FOR THIS INSTALLATION PER THE FOLLOWING INSTRUCTIONS.
 - 2.1. STARTING AT THE FRONT, INSTALL 5/16" MULTI THREAD U-NUTS (ITEM #6) IN THE TOP REAR HOLE OF THE FIRST AND SECOND PATTERNS AND IN THE FRONT TOP HOLE OF THE THIRD OR REAR PATTERN AS SHOWN. INSTALL THESE U-NUTS SO THAT THE THREADS ARE TO THE INSIDE OF THE ROCKER PANEL. (THIS IS DONE BY INSERTING THE THREADED HALF OF THE U-NUT THRU THE LARGE ACCESS HOLES AND SLIDING THE U-NUT TOWARDS THE ROUND HOLE UNTIL IT SEATS IN THE ROUND HOLE).
3. ATTACH THE MOUNTING BRACKETS (ITEM #2 & #3) TO THE VEHICLE. (**NOTE: THE FRONT MOUNTING BRACKET, ITEM #2, HAS A 3/16" OFFSET AT THE TOP OF THE BRACKET.**)
 - 3.1. POSITION THE BRACKETS ON THE VEHICLE SO THAT THE TOP HOLE LINES UP WITH THE MULTI THREAD U-NUT AND THE BOTTOM HOLE LINES UP WITH THE HOLE IN THE PINCH WELD. ATTACH THE TOP OF THE BRACKET WITH A 5/16" X 1.00" ZINC PLATED HEX HEAD CAP SCREW (ITEM #7) AND 5/16" ZINC PLATED FLAT WASHER (ITEM #8). ATTACH THE BOTTOM OF THE BRACKET TO THE PINCH WELD WITH A 5/16" X 1.00" BLACK PLATED HEX HEAD CAP SCREW (ITEM #9), 5/16" BLACK PLATED FLAT WASHER (ITEM #10) AND 5/16" SERRATED FLANGE NUT (ITEM #5). LEVEL THE BRACKETS AND TIGHTEN THE FASTENERS TO 19 LB FT.
4. ATTACH THE STEP (ITEM #1) TO THE MOUNTING BRACKETS.
 - 4.1. INSERT THREE (3) 5/16" SQUARE HEAD SCREWS (ITEM #4) IN THE CENTER SLOT ON THE UNDER SIDE OF THE STEP.
 - 4.2. POSITION THE STEP ON THE MOUNTING BRACKETS SO THAT THE SQUARE HEAD SCREWS ARE LOCATED IN THE SLOTS OF THE MOUNTING BRACKETS AND THE STEP IS CENTERED, FRONT TO REAR, ON THE CAB.
 - 4.3. LOCATE THE STEP, IN AND OUT, AS DESIRED, INSTALL 5/16" SERRATED FLANGE NUTS (ITEM #5) ON THE SQUARE HEAD SCREWS AND TIGHTEN TO 19 LB FT.
 - 4.4. INSTALL 5/16-18 SERRATED FLANGE NUTS (ITEM #5) ON ANY UNUSED SQUARE HEAD SCREWS IN THE INBOARD SLOT OF THE STEP AND TIGHTEN TO 19 LB FT.

SERVICE PARTS LIST

ITEM	PART NO.	QTY	DESCRIPTION
1		2	MEGA STEP BOARD ASSEMBLY (SOLD SEPARATELY) LENGTH WILL VARY DEPENDING ON APPLICATION
2	551562	2	BRKT- MTG, STEP, SUPER DUTY PICKUP, FRONT
3	551563	4	BRKT- MTG, STEP, SUPER DUTY PICKUP
4	106880	6	SCREW-SQUARE HEAD, 5/16_18 UNC
5	102680	18	NUT-SERRATED FLANGE, HEX, SST, 5/16-18 UNC
6	104264	6	U-NUT- MULTI THREAD, 5/16-18 UNC, STL, BLK
7	100647	6	SCREW- HEX HEAD CAP, 5/16_18 UNC X 1.00".ZP
8	100034	6	WSHR-PL, A, STL, 5/16,.375 ID X .875 OD X .083 THK, ZP
9	106997	6	SCREW- HEX HEAD CAP, 5/16_18 UNC X 1.00", SST, BZP
10	106998	6	WSHR-PL, A, SST, 5/16,.375 ID X .875 OD X .083 THK, BZP

SERVICE PARTS LIST

BRACKET NO. - 579921

LUVERNE LOGO SHOULD BE TOWARD REAR OF VEHICLE

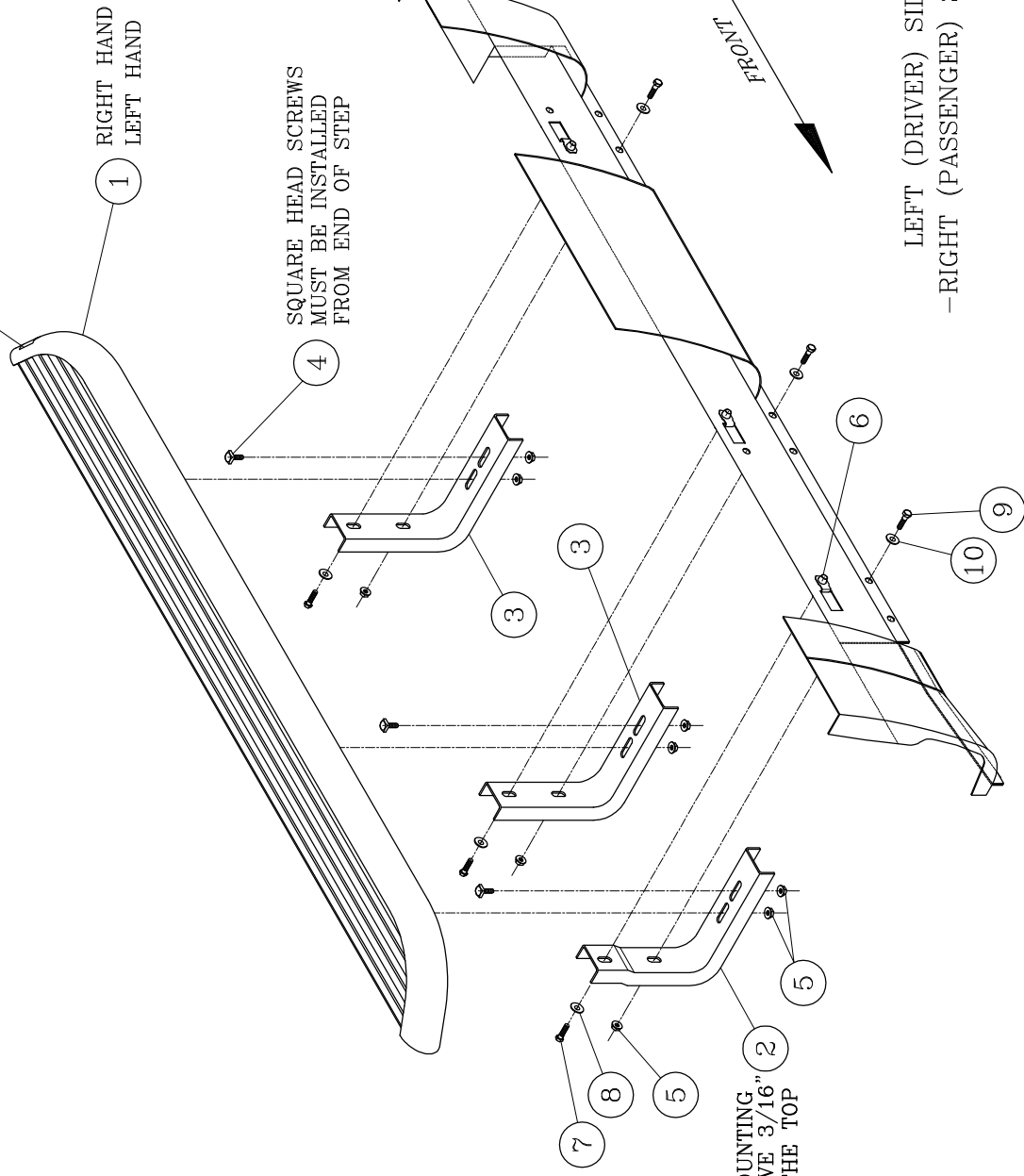

1 RIGHT HAND
LEFT HAND

4 SQUARE HEAD SCREWS
MUST BE INSTALLED
FROM END OF STEP

FRONT

LEFT (DRIVER) SIDE SHOWN
-RIGHT (PASSENGER) SIDE OPPOSITE-

FRONT MOUNTING
BRACKETS HAVE 3/16"
OFFSET AT THE TOP



1700 Birch Street
Brandon, SD 57005