

# INSTALLATION INSTRUCTIONS AND PARTS LIST

MODEL 585254, 586254  
54" O-MEGA STEPS  
UNIVERSAL APPLICATION

1. READ INSTRUCTIONS COMPLETELY AND CHECK TO MAKE SURE THAT ALL REQUIRED PARTS (LISTED ON THE SERVICE PARTS LIST) ARE ON HAND BEFORE STARTING THE INSTALLATION.
2. FOLLOW THE INSTRUCTIONS INCLUDED WITH THE SPECIFIC BRACKET PACKAGE THAT YOU ARE USING, TO MOUNT THE BRACKETS TO YOUR VEHICLE.
3. BEFORE ATTACHING THE O-MEGA STEPS TO THE BRACKETS, MOUNT THE STEP PADS (ITEM #2) TO THE STEP PLATES USING THE 1/2" TEK SCREWS (ITEM #6) PROVIDED. POSITION THE STEP PAD ACCORDINGLY FOR YOUR VEHICLE. WHEN INSTALLING THE PADS ON THE STEPS, DRILL AND INSTALL THE TWO CENTER SCREWS FIRST. IF INSTALLING THE PADS WHEN THE TEMPERATURE IS AROUND 70° F., MAKE SURE THE SCREWS IN THE END SLOTTED HOLES ARE IN THE MIDDLE OF THE SLOT. WHEN TURNING IN THE SCREWS, TURN THEM IN SNUG THEN BACK OFF A ¼ TURN. PLASTIC WILL EXPAND WHEN IT IS HOT AND CONTRACT WHEN IT GETS COLD AND THE SLOT WILL ALLOW THIS TO HAPPEN WITHOUT RISING UP BETWEEN THE SCREWS.
4. INSTALL THE REQUIRED NUMBER OF SQUARE HEAD SCREWS (ITEM#4) INTO THE DESIGNATED SLOTS IN THE BOTTOM OF THE STEP PLATES.
5. INSTALL THE END CAPS (ITEM #3) AS SHOWN IN (FIG.1), TIGHTENING THE SERRATED NUTS (ITEM#5) TO 5 LB FT.
6. POSITION THE O-MEGA STEP ON THE MOUNTING BRACKETS SO THAT THE SQUARE HEAD SCREWS (ITEM #4) ARE LOCATED IN THE SLOTS OF THE MOUNTING BRACKETS AND THE STEP IS CENTERED, SIDE TO SIDE, ON THE VEHICLE. INSTALL 5/16" SERRATED FLANGE NUTS (ITEM #5) ON THE SQUARE HEAD SCREWS (ITEM #4) AND TIGHTEN TO 19 LB FT.

## SERVICE PARTS LIST

ITEM	PART NO.	QTY	DESCRIPTION
1	107959	1	EXTRUSION-AL, 51.00"OMEGA STP, SATIN
1	551949	1	EXTRUSION-AL, 51.00"OMEGA STP, BLACK
2	107957	2	PAD-STEP PLATE, 4.50 X 20.00
3	107956	2	CAP-END,PLSTC,2.95 X 6.70
4	106880	8	SCREW-SQ HD,5/16-18 X 1,MAGNIGUARD
5	102680	8	NUT-SERR FLG,HX,SST,WX,5/16-18
6	107958	12	SCREW-PPH,TEK,#8-18 X 1/2",SST,BZP



(A LUVERNE Company)

1200 E. Birch St.

Brandon, SD 57005

552518 SHEET 1 OF 2 13JUN14

SERVICE PARTS LIST

PACKAGE NO. - 585254  
PACKAGE NO. - 586254

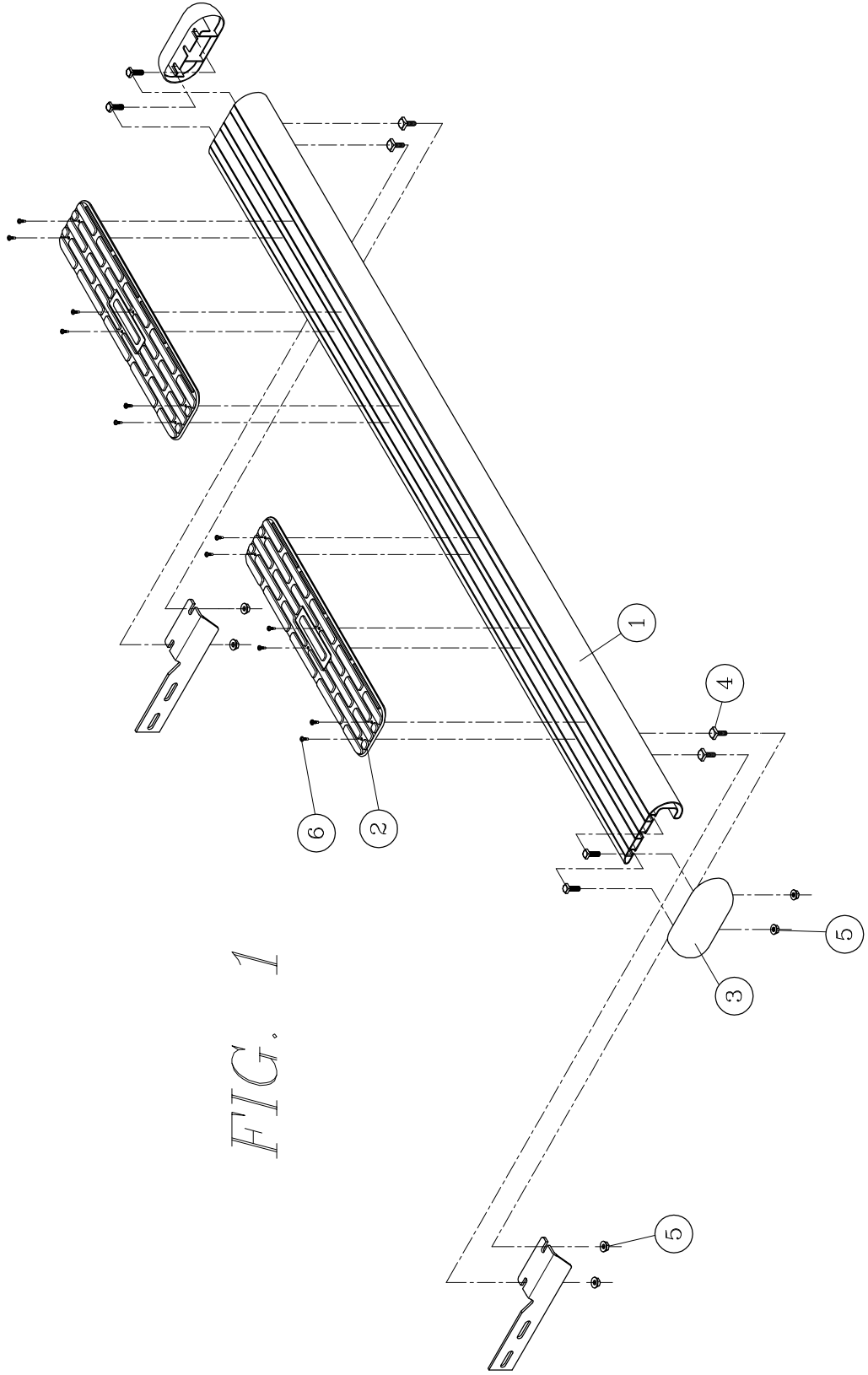

FIG. 1

# INSTALLATION INSTRUCTIONS AND PARTS LIST

FOR MOUNTING 401473 GRIP STEPS PASSENGER CARGO DOOR ONLY  
2014-NEWER RAM PROMASTER VANS

READ INSTRUCTIONS COMPLETELY AND CHECK TO MAKE SURE THAT ALL REQUIRED PARTS  
(LISTED ON SERVICE PARTS LIST) ARE ON HAND BEFORE STARTING THE INSTALLATION.

1. DETERMINE THE FRONT TO BACK PLACEMENT OF THE BRACKETS, AND PLACE THE FORWARD BRACKET (ITEM #1) UP TO THE INSIDE OF THE PINCH WELD AND SECURE IT USING A CLAMP. SOME UNDER COATING MAY NEED TO BE SCRAPPED OFF SO THE BRACKET WILL SIT FLAT WITH THE PINCH WELD.
2. USING THE HOLES IN THE BRACKET AS A REFERENCE, MARK THE CENTER OF (2) HOLES IN THE PINCH WELD, AND (2) HOLES INTO THE FLOOR OF THE VAN. REMOVE THE BRACKET FOR DRILLING. THE TWO HOLES MARKED ON THE PINCH WELD WILL BE DRILLED WITH A 11/32 DRILL BIT. THE HOLES IN THE FLOOR SHOULD BE DRILLED TO 1/4" DIAMETER IF USING THE SUPPLIED SELF TAPPING SCREWS.  
**IF YOU HAVE ACCESS TO 1/4-20 RIV-NUT TYPE FASTENERS, THEY COULD BE USED INSTEAD OF THE SELF TAPPING SCREWS.**
3. INSTALL THE BRACKET (ITEM # 1) AND FASTEN IT TO THE PINCH WELD USING THE BLACK 5/16-18 BOLTS, WASHERS, NUTS, AND RETAINER PLATE (ITEM #3, 4, 5 & 6). LEAVE THEM LOOSE AT THIS TIME. INSTALL THE 5/16 X 3/4" SELF TAPPING SCREW AND ZINC WASHER (ITEM #7 & 8). OR THE ZINC 1/4-20X1.00" SCREWS AND ZINC WASHERS AND LOCK WASERS (ITEM#7,9,10).
4. TIGHTEN ALL FASTENERS
5. REPEAT FOR THE REAR BRACKET (ITEM #2).

## SERVICE PARTS LIST

ITEM	PART NO.	QTY	DESCRIPTION
1	552407	1	MTG-BRKT, FRONT (GRIP STEPS)
2	552408	1	MTG-BRKT, REAR (GRIP STEPS)
1	552431	1	MTG-BRKT, FRONT (MEGA/O-MEGA STEPS)
2	552432	1	MTG-BRKT, REAR (MEGA/O-MEGA STEPS)
3	552410	2	RETAINER PLATE, GALV
4	100180	4	SCR-HHCAP, M8-1.25X30MM, SST, BZP
5	106998	4	WASHER-FL, 5/16, BZP
6	105859	4	NUT-HEX FLG, M8-1.25X25MM,ZP
7	100016	4	WASHER-FL, 5/16, ZP
8	104267	4	SCR-HWH, TF, AB, SST, 5/16 X .750
9	101381	4	SCR-HHCAP, 1/4-20X1.00, SST
10	101366	4	WASHER-LK,1/4",SST



1200 E. Birch St.

Brandon, SD 57005

REV A 14SEP15  
552421 SHEET 1 OF 2 23JUL14

SERVICE PARTS LIST

BRACKET NO. - 401473  
- 571473

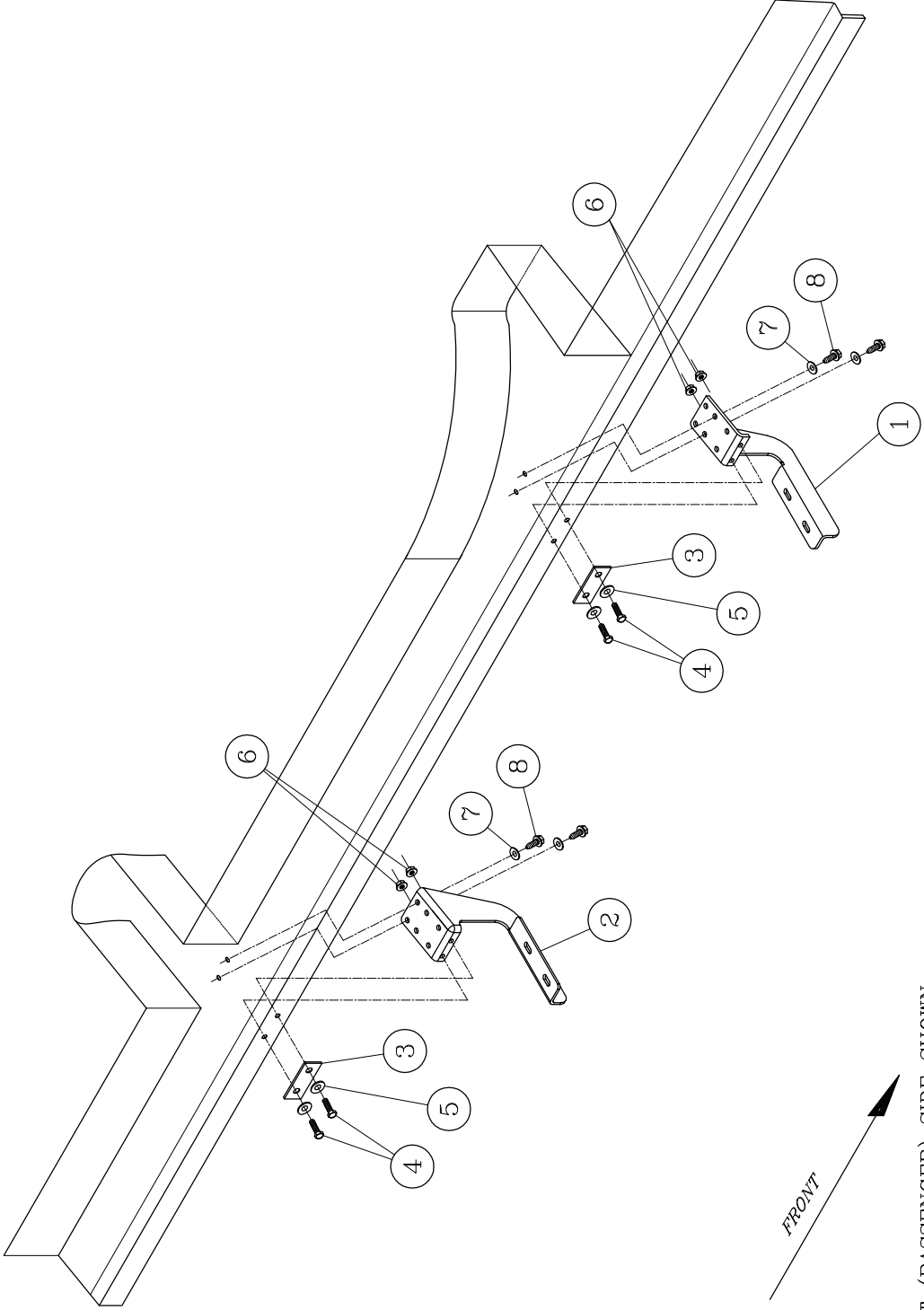

RIGHT (PASSENGER) SIDE SHOWN

**LOVERNE**  
TRUCK EQUIPMENT  
(A LOVERNE Company)

1200 E. Birch St.  
Brainerd, SD 57006