

# S4400

2016-2024 INFINITI Q50, 3.0L, RWD/AWD,  
CAT-BACK, 3.0" DUAL REAR

# MBRP®

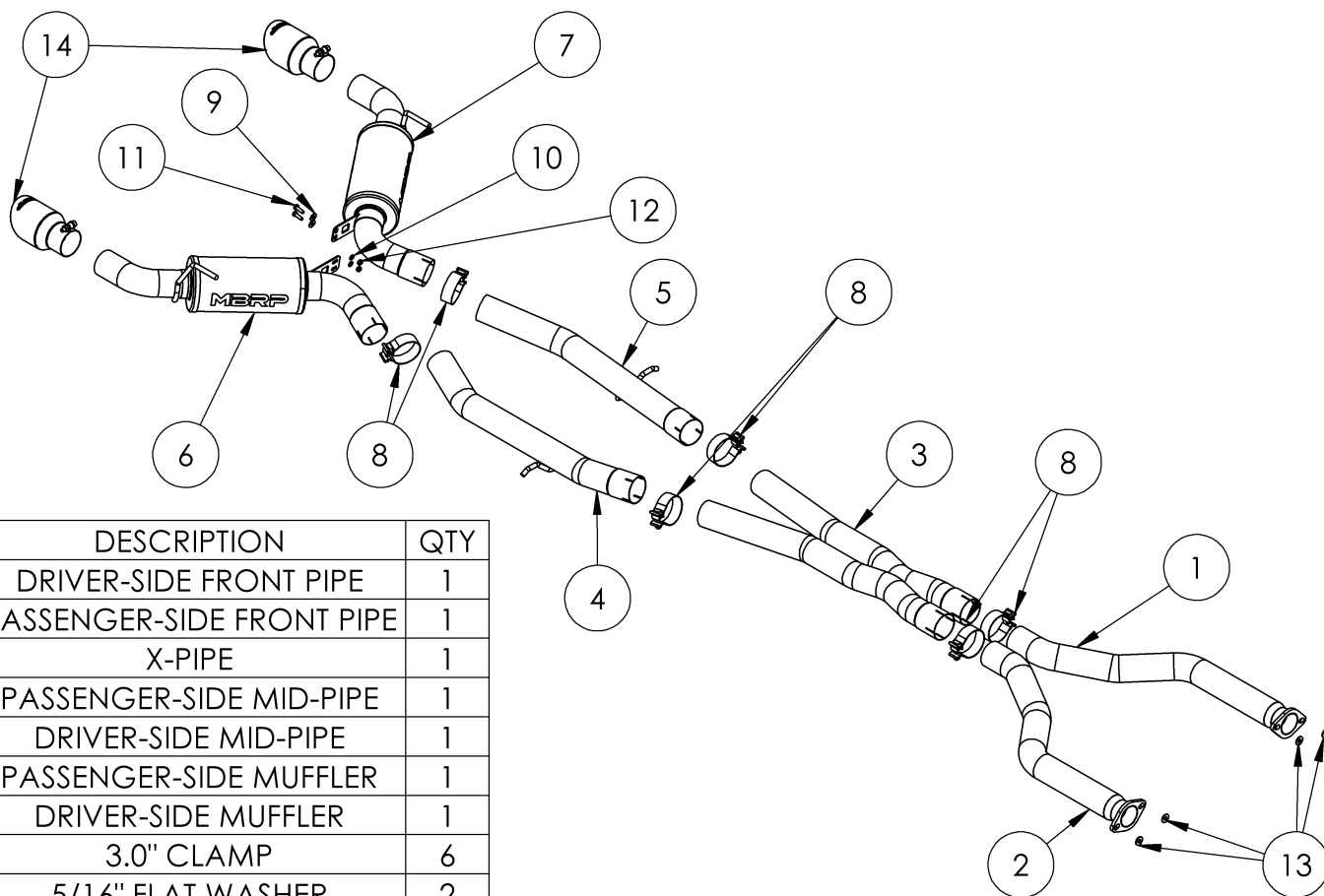

ITEM	DESCRIPTION	QTY
1	DRIVER-SIDE FRONT PIPE	1
2	PASSENGER-SIDE FRONT PIPE	1
3	X-PIPE	1
4	PASSENGER-SIDE MID-PIPE	1
5	DRIVER-SIDE MID-PIPE	1
6	PASSENGER-SIDE MUFFLER	1
7	DRIVER-SIDE MUFFLER	1
8	3.0" CLAMP	6
9	5/16" FLAT WASHER	2
10	5/16" LOCK WASHER	2
11	5/16" HEX BOLT X 1"	2
12	5/16" HEX NUT	2
13	3/8" FLAT WASHER	4
14	TIP	2

## PLEASE READ BEFORE STARTING INSTALLATION

**While MBRP has made every effort to ensure that all components of this system are of superior quality and properly packaged, it is the installer's responsibility to ensure the following before removal of the factory exhaust:**

- that ALL components shown above are present.
- that ALL mating components fit together.
- that there are no damaged components.
- that the system you have purchased is appropriate for your vehicle year, model and configuration.
- that the system will not interfere with any modifications previously installed or planned.
- that you have read and understand these instructions.

If you have any questions or are uncertain about any aspect of the installation of this system to your vehicle please contact your dealer before commencing installation.

# MBRP®

## Removal of Stock System



**Figure 1**



**Figure 2**



**Figure 3**



**Figure 4**



**Figure 5**

**1.** Apply penetrating lubricant liberally to all exhaust fasteners, hangers and rubber insulators.

**2.** Remove the front pipe nuts after the catalytic converters and save the nuts for the installation. Remove the chassis cross-brace (optional, but it allows removal of the factory exhaust in one-piece).

**Refer to Figure 1.**

**3.** Remove the hangers from the rubber insulators and remove the exhaust from the vehicle. Ensure the factory gaskets remain on the catalytic converters for installation.

## Installation of MBRP Performance Exhaust

**1.** Using the factory nuts removed in **Step 2**, and four **3/8” Flat Washers**, loosely attach the **Front Pipes** onto the catalytic converters.

**Refer to Figure 2.**

**2.** Using two **3” Clamps**, loosely install the **X-Pipe** onto both **Front Pipes**. The **X-Pipe** outlets should be pointing slightly down. Reinstall the chassis cross-brace (if removed).

**Refer to Figure 3.**

**3.** Using two **3” Clamps**, loosely install both **Mid-Pipes**. Place the hangers into the factory rubber insulators and place a **3” Clamp** onto each pipe.

**Refer to Figure 4.**

**4.** Place the **Passenger-Side Muffler** hanger into the passenger-side factory insulator. Loosely install the **Passenger-Side Muffler** onto the **Passenger-Side Mid-Pipe**.

**Refer to Figure 5.**

# MBRP®



**Figure 6**

5. Place the **Driver-Side Muffler** hanger into the driver-side factory insulator. Loosely install the **Driver-Side Muffler** onto the **Driver-Side Mid-Pipe**. Refer to **Figure 6**.

6. Using the **5/16" Hardware**, loosely attach both **Mufflers** cross-braces together. The driver-side brace goes behind the passenger-side. Refer to **Figure 7**.

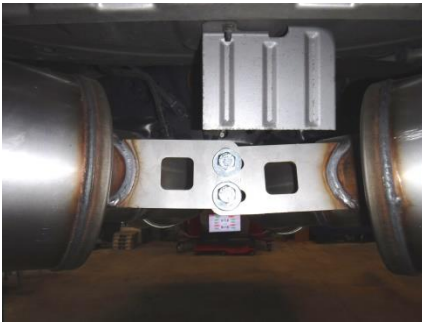

**Figure 7**

7. Install the **Tips**, and adjust to your liking, but ensure the mounting hardware is behind the trunk seam. The **Tips** can be adjusted in farther, but you may need to provide clearance at the seam.

Refer to **Figure 8**.



**Figure 8**

8. Carefully align the system and tips. Align the edge of each band clamp with the edge of the joint it is connecting. Tighten all hardware and clamps, starting at the front and working rearward to secure the system. Check along the full length of the exhaust system to ensure there is adequate clearance for fuel lines, vent lines, brake lines, frame, bodywork, suspension and any wiring, etc. If there is any interference detected, relocate or adjust to provide adequate clearance. Ensure all clamp connections are secure and components are unable to rotate or slide. Band clamps require approximately 45 lb-ft (60 N-m) of torque. Verify clearances, system security and band clamp torque after 30-60 miles (50-100 km) of driving.



**Congratulations!** You are ready to begin experiencing the improved power, sound and driving experience of your **MBRP** Performance Exhaust.

We know you will enjoy your purchase!