



INSTALLATION INSTRUCTIONS



2010-2014 Audi A5 Quattro 2.0L

PART NO. 15314

BILL OF MATERIALS:

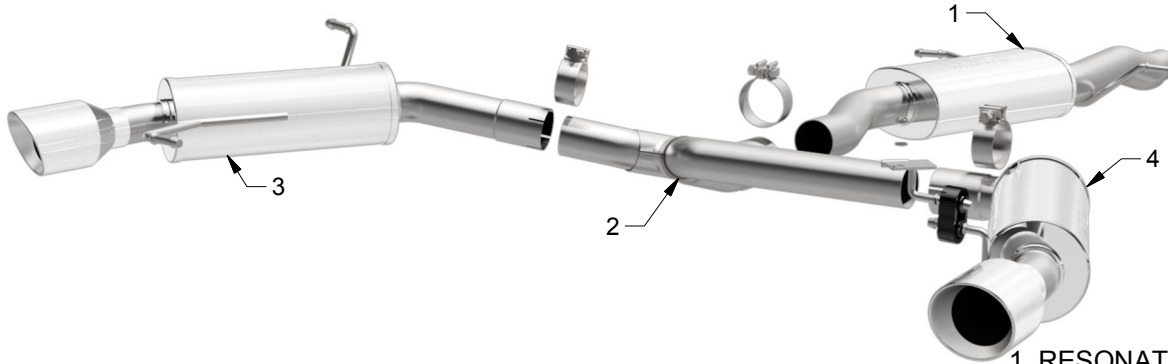

- 1. RESONATOR ASSEMBLY
- 2. Y-PIPE ASSEMBLY
- 3. MUFFLER ASSEMBLY D/S
- 4. MUFFLER ASSEMBLY P/S



WEAR SAFETY
GLASSES



READ INSTRUCTIONS
THOROUGHLY BEFORE
INSTALLING PRODUCT

SHOP SUPPLIES:



SPRAY LUBRICANT

To ease removal of existing exhaust components (especially on older vehicles) spray penetrating lubricant on all fasteners and hangers/insulators that will be loosened or removed and let soak before disassembly.

HARDWARE KIT:

- 1.[1] 3.00" Clamp
- 2.[2] 2.50" Clamp
- 3.[1] Nut M8-1.25
- 4.[1] Lock Washer 5/16"
- 5.[1] Hanger Brkt Assy
- 6.[1] Hanger Rubber Insulator

MINIMUM REQUIRED TOOLS:



10mm, 13mm, 15mm,
17mm, T-20 Torx



Hanger Tool
(Or Pry Bar)



Flat Head
Screw Driver

MAGNAFLOW RECOMMENDS PROFESSIONAL INSTALLATION ON ALL THEIR PRODUCTS



WARNING: When working on, under, or around any vehicle exercise caution. Please allow the vehicle's exhaust system to cool before removal, as exhaust system temperatures may cause severe burns. If working without a lift always consult vehicle manual for correct lifting specifications. Always wear safety glasses and ensure a safe work area. Serious injury or death could occur if safety measures are not followed.

ATTENTION: Always install any supplied band or U-bolt clamps to the proper torque specifications of 40-45 ft-lbs for band clamps and 30-35 ft-lbs for U-bolt clamps. Over tightening will result in the clamp breaking and will NOT be warranted by MagnaFlow.

INSTALLATION INSTRUCTIONS

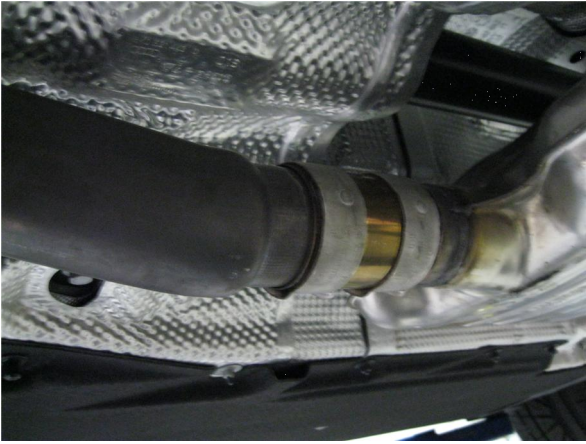

Step 1. (Before you start be aware that the rear single outlet valance needs to be replaced with a dual outlet valance in order to work.) Start by removing the support bracket from the front of the vehicle and unfasten the Resonator Inlet Pipe from the catalytic converter. Disengage the exhaust hangers from the rubber insulators (Save the insulators as they will be re-used on the new system), and remove the exhaust system.



Step 2. Next remove the rear single outlet valance, and replace it with a dual outlet valance (As Shown.) Ref. # 8T0807521G01C

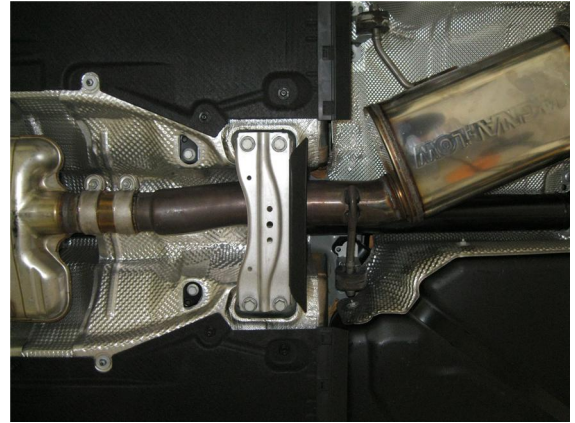

Step 3. Begin installation of your new MAGNAFLOW exhaust system by attaching the Resonator Inlet Pipe to catalytic converter using the OEM clamp. Insert hangers into OEM rubber insulators and re-install the support bracket.



Step 4. Next, install the Y-Pipe Assembly using the supplied 3.00" clamp (keep clamps loose until final adjustment of system).



Step 5. Then install D/S Muffler Assembly in a similar fashion as the Y-Pipe assembly using the supplied 2.50" clamp and inserting the hangers into the OEM rubber insulators.



Step 6. To Install the P/S Muffler Assembly you will first, need to install the hanger bracket assembly into the pre-existing hole using the supplied 13mm nut, washer and rubber insulator. then install the P/S Muffler Assembly in similar fashion as the D/S using the supplied 2.50" clamp and inserting the hanger in to the rubber insulator.



Step 7. Once a final position has been chosen for the new exhaust system, evenly tighten all clamps from front to rear using the torque specifications on page one of the instructions. Inspect all fasteners after 25-50 miles of operation and re-tighten if necessary.