



INSTALLATION INSTRUCTIONS



2013-2014 FORD F-150 3.7L | PART NO. 15325

BILL OF MATERIALS:

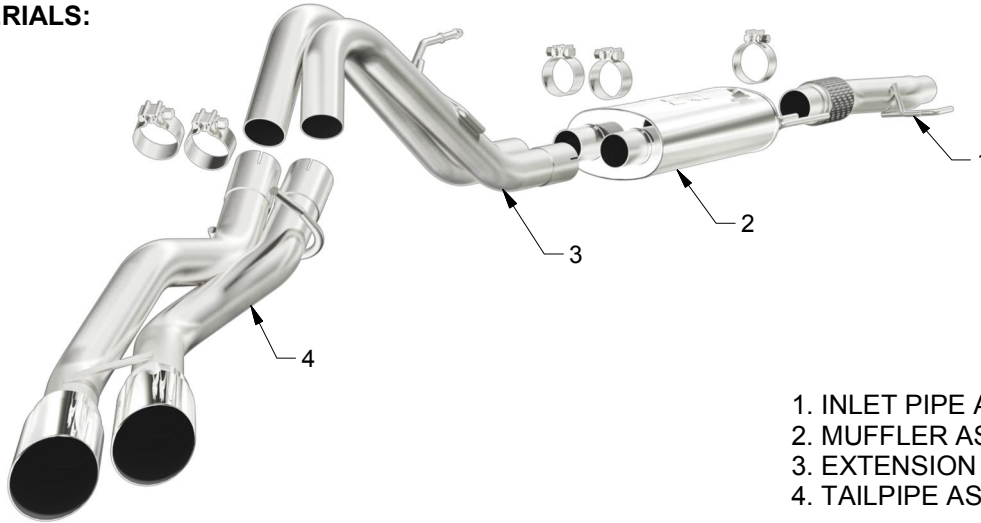

- 1. INLET PIPE ASSEMBLY
- 2. MUFFLER ASSEMBLY
- 3. EXTENSION PIPE ASSEMBLY
- 4. TAILPIPE ASSEMBLY



WEAR SAFETY GLASSES



READ INSTRUCTIONS THOROUGHLY BEFORE INSTALLING PRODUCT

SHOP SUPPLIES:



SPRAY LUBRICANT

To ease removal of existing exhaust components (especially on older vehicles) spray penetrating lubricant on all fasteners and hangers/insulators that will be loosened or removed and let soak before disassembly.

HARDWARE KIT:

- 1.[1] 3.00" Clamp
- 2.[4] 2.50" Clamp

MINIMUM REQUIRED TOOLS:



15mm



Hanger Tool (Or Pry Bar)



Sawzall or other cutting device.

MAGNAFLOW RECOMMENDS PROFESSIONAL INSTALLATION ON ALL THEIR PRODUCTS



WARNING: When working on, under, or around any vehicle exercise caution. Please allow the vehicle's exhaust system to cool before removal, as exhaust system temperatures may cause severe burns. If working without a lift always consult vehicle manual for correct lifting specifications. Always wear safety glasses and ensure a safe work area. Serious injury or death could occur if safety measures are not followed.

ATTENTION: Always install any supplied band or U-bolt clamps to the proper torque specifications of 40-45 ft-lbs for band clamps and 30-35 ft-lbs for U-bolt clamps. Over tightening will result in the clamp breaking and will NOT be warranted by MagnaFlow.

INSTALLATION INSTRUCTIONS



Step 1. To remove the OEM exhaust system, you will need to cut the pipe behind the muffler before it goes over the axle. You can then disengage the welded hangers from the OEM rubber insulators and remove the tailpipe. Unfasten the clamp attaching the OEM muffler inlet to the OEM catalytic converter. Do not damage or discard the OEM fasteners or rubber insulators, as they will be reused to mount the new system. Disengage the muffler hangers and remove the OEM exhaust from the vehicle.



Step 2. To begin, fasten the Inlet Pipe Assembly to the catalytic converter using the OEM clamp assembly and by fitting the welded hanger into the OEM rubber insulator (Leave all clamps and fasteners loose for final adjustment of the complete system.) Install the Muffler to the Inlet Pipe Assembly using the supplied 3.00" clamp and fitting the hanger. Next install the Tailpipe Extension Assembly to the Muffler in the similar fashion using the supplied 2.50" clamps.



Step 3. Finish by installing the Tail Pipe Assembly to the Tail Pipe Extension Assembly using the supplied 2.50" clamps, fitting the welded hanger into rubber insulator.

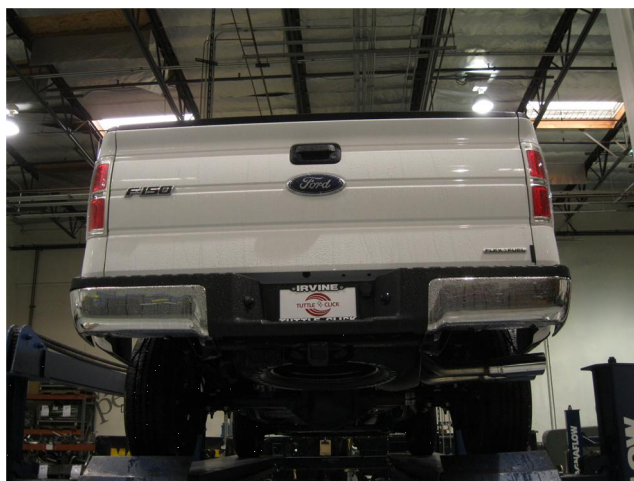

Step 4. Once a final position has been chosen for the new exhaust system, evenly tighten all clamps from front to rear using the torque specifications on page one of the instructions. Inspect all fasteners after 25-50 miles of operation and re-tighten if necessary.