

### 2003 - 2007 Ford 6.0L Diesel Muffler Delete

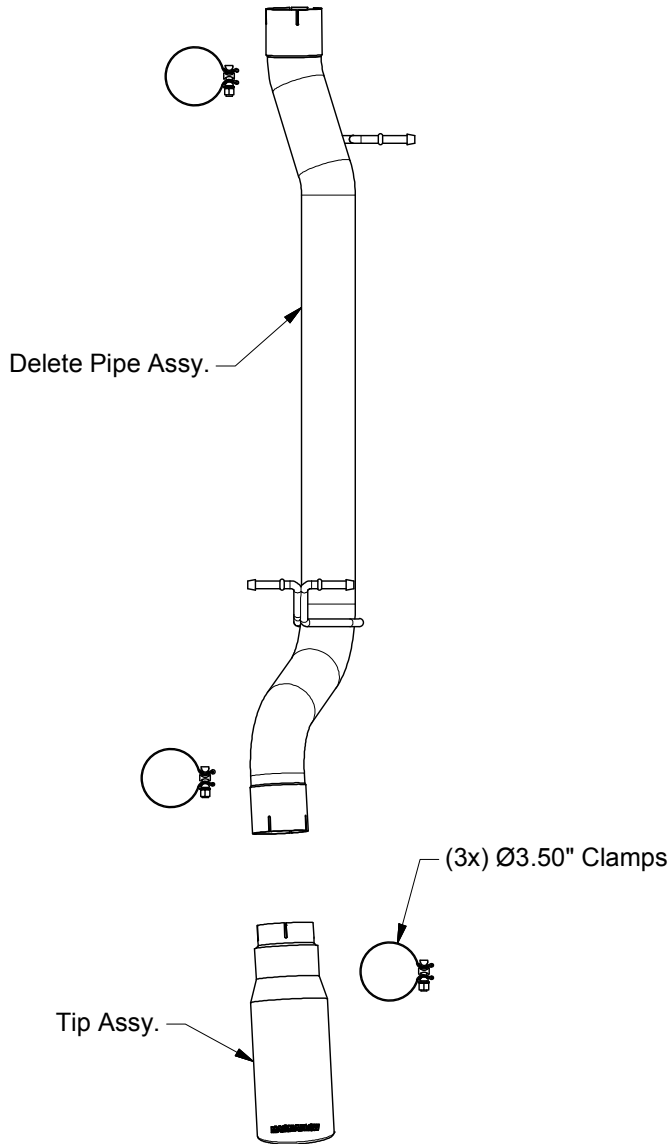

**Warning:** When working on, under, or around any vehicle exercise caution. Please allow the vehicle's exhaust system to cool before removal, as exhaust system temperatures may cause severe burns. If working without a lift, always consult vehicle manual for correct lifting specifications. Always wear safety glasses and ensure a safe work area. Serious injury or death could occur if safety measures are not followed.

**Step 1:** (Carefully read all instructions before installation) To remove the OEM muffler, you will need to measure and cut the tailpipe 15" behind the two hangers at the rear of the muffler. You can then unbolt the clamp at the inlet of the muffler, disengage the welded hangers from the rubber insulators, and remove it from the vehicle.

**Step 2:** Be sure to deburr the cut pipe, then install the new Delete Pipe Assembly by fitting the welded hangers into the rubber insulators, and by fastening the inlet and outlet to the OEM catalytic converter and tailpipe. The polished tip can be directly fastened to the OEM tailpipe using a supplied 3.50" clamp, however, you may want to trim the tailpipe for final tip placement.

**Step 3:** With all components mounted loosely, adjust the system for overall aesthetics and clearance of frame & bodywork. (MAGNAFLOW recommends at least 1/2" of clearance between the exhaust system and any body panels to prevent heat-related body damage or fire.)

**Step 4:** Once a final position has been chosen for the new system, evenly tighten all fasteners from front to rear. The supplied band clamps must be VERY tight to properly align the pipes and prevent leaks (Approximately 40ft-lbs). U-bolt clamps should be tightened to approximately 30-35ft-lbs. Inspect all fasteners after 25-50 miles of operation and retighten if necessary.

**\*\* Magnaflow Performance Exhaust recommends professional installation on all their products**