



# INSTALLATION INSTRUCTIONS



2001-2007.5 CHEVROLET 2500HD 6.6L | PART NO. 18931

## BILL OF MATERIALS:

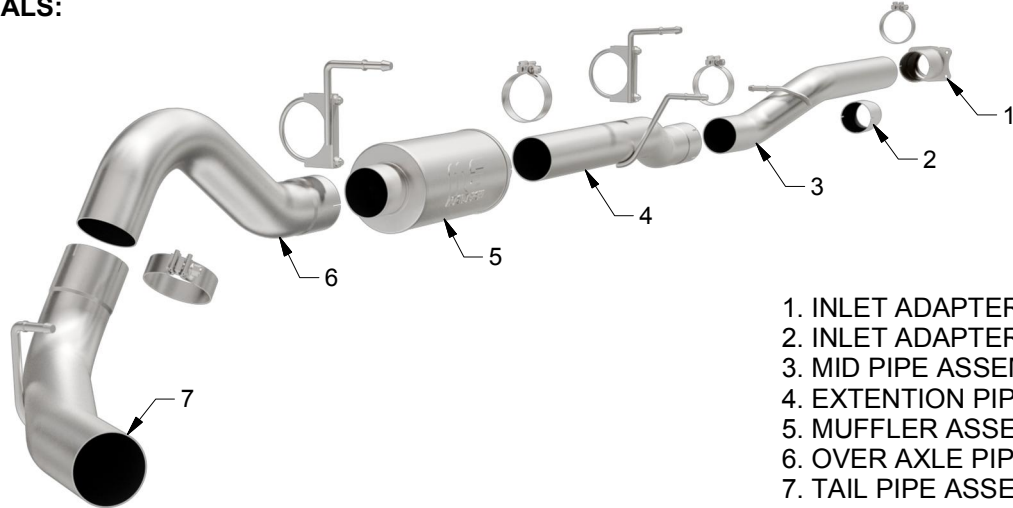

1. INLET ADAPTER '01 - '05
2. INLET ADAPTER '06 - '07.5
3. MID PIPE ASSEMBLY
4. EXTENSION PIPE ASSEMBLY
5. MUFFLER ASSEMBLY
6. OVER AXLE PIPE
7. TAIL PIPE ASSEMBLY



WEAR SAFETY GLASSES



READ INSTRUCTIONS THOROUGHLY BEFORE INSTALLING PRODUCT

## SHOP SUPPLIES:



SPRAY LUBRICANT

To ease removal of existing exhaust components (especially on older vehicles) spray penetrating lubricant on all fasteners and hangers/insulators that will be loosened or removed and let soak before disassembly.

## HARDWARE KIT:

1. [4] 4.00" Torca Clamp
2. [2] 4.00" Clamp Hanger
3. [4] 3/8 Nuts
4. [2] 4.00" U-Bolt

## MINIMUM REQUIRED TOOLS:



15mm



Hanger Tool (Or Pry Bar)



SAWZALL, SIMILAR CUTTING TOOL

## MAGNAFLOW RECOMMENDS PROFESSIONAL INSTALLATION ON ALL THEIR PRODUCTS



**WARNING:** When working on, under, or around any vehicle exercise caution. Please allow the vehicle's exhaust system to cool before removal, as exhaust system temperatures may cause severe burns. If working without a lift always consult vehicle manual for correct lifting specifications. Always wear safety glasses and ensure a safe work area. Serious injury or death could occur if safety measures are not followed.

**ATTENTION:** Always install any supplied band or U-bolt clamps to the proper torque specifications of 40-45 ft-lbs for band clamps and 30-35 ft-lbs for U-bolt clamps. Over tightening will result in the clamp breaking and will NOT be warranted by MagnaFlow.

MAGNAFLOW: 1901 Corporate Centre Drive - Oceanside, CA 92056 | 1(800) 990-0905  
Technical Support: 1(800) 959-9226 | Email: [moreinfo@magnaflow.com](mailto:moreinfo@magnaflow.com)

## INSTALLATION INSTRUCTIONS



**Step 1.** To begin the removal of the OEM system you will need to unfasten the inlet. For vehicles '01 - '05 you will need to unbolt the inlet flange. For vehicles '06 - '07.5 there is a slip clamp that needs to be loosened. You can then disengage the welded hangers from the rubber insulators, working rearward finish removing the system. You may need to cut the OEM system to ease the removal process. Do not damage or discard the OEM fasteners and rubber insulators, as they will be reused to mount the new system.



**Step 2.** Before installing your new system select the correct inlet adapter for your vehicles year. The larger adapter with the flange attached covers '01 - '05, the slip adapter covers '06 - '07.5. Attach the appropriate adapter by either bolting it to the vehicle outlet using the OEM fasteners or inserting the adapter into the slip clamp and loosely securing.



**Step 3.** The inlet end of the Mid Pipe Assembly may need to be trimmed depending on the year and cab configuration of your vehicle.

'01 - '05 Extended Cab: Cut 9.00"

'06 - '07.5 Extended Cab: Cut 11.00"

'06 - '07.5 Crew Cab: Cut 4.00"

'01 - '05 Crew Cab: DO NOT CUT

Once the appropriate cut has been made you can now loosely attach the Mid Pipe Assembly to the Inlet Adapter with the supplied 4.00" Torca Clamp.



**Step 4.** For Short Bed models 13.00" needs to be cut from the outlet end on the Extension Pipe Assembly. Assemble and attach the U-Bolt Hanger assembly to the Extension Pipe Assembly as shown. There is a welded hanger on the pipe assembly that isn't used for Crew Cab, Short Bed versions of this truck. Loosely attach the Extension Pipe Assembly to the Mid Pipe Assembly using the supplied 4.00" Torca Clamp.

## INSTALLATION INSTRUCTIONS



**Step 5.** Install the Muffler Assembly, Over Axle Pipe and Tail Pipe Assembly in a similar fashion to the Extension Pipe Assembly using the supplied clamps. Engage all welded hangers to the rubber insulators.



**Step 6.** Once a final position has been chosen for the new exhaust system, evenly tighten all clamps from front to rear using the torque specifications on page one of the instructions. Inspect all fasteners after 25-50 miles of operation and re-tighten if necessary.