



# INSTALLATION INSTRUCTIONS



Ford Mustang 5.0L

PART NO. 19643

## BILL OF MATERIALS:

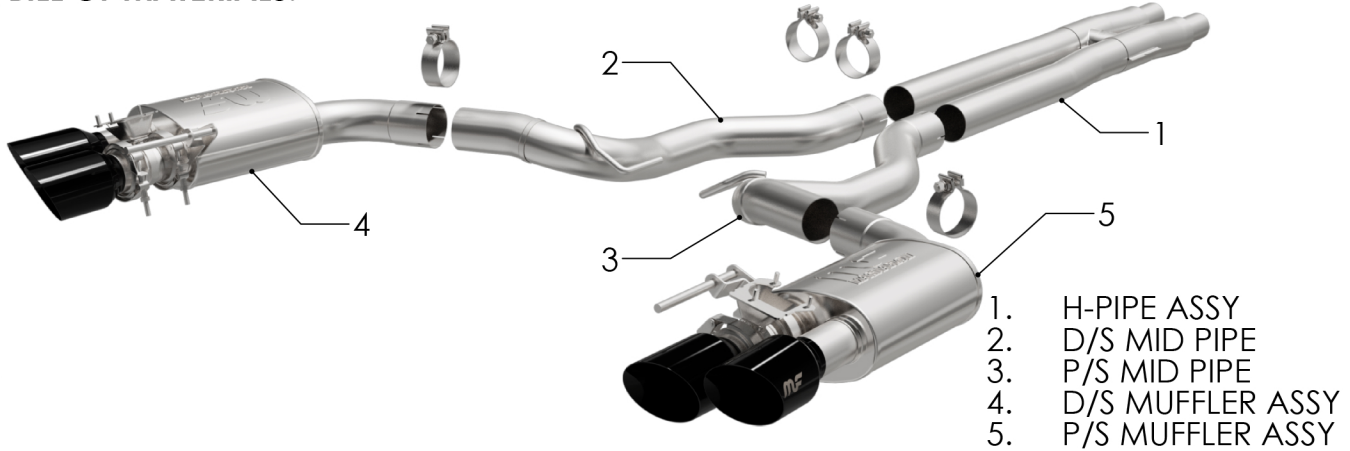

WEAR SAFETY GLASSES



READ INSTRUCTIONS THOROUGHLY BEFORE INSTALLING PRODUCT



SPRAY LUBRICANT

To ease removal of existing exhaust components (especially on older vehicles) spray penetrating lubricant on all fasteners and hangers/insulators that will be loosened or removed and let soak before disassembly.

## HARDWARE KIT:

- 1. [4] 3.00" Clamp

## SHOP SUPPLIES:

## MINIMUM REQUIRED TOOLS:



14, 15 mm



Hanger Tool (Or Pry Bar)

## MAGNAFLOW RECOMMENDS PROFESSIONAL INSTALLATION ON ALL THEIR PRODUCTS



**WARNING:** When working on, under, or around any vehicle exercise caution. Please allow the vehicle's exhaust system to cool before removal, as exhaust system temperatures may cause severe burns. If working without a lift always consult vehicle manual for correct lifting specifications. Always wear safety glasses and ensure a safe work area. Serious injury or death could occur if safety measures are not followed.

**ATTENTION:** Always install any supplied band or U-bolt clamps to the proper torque specifications of 40-45 ft-lb for band clamps and 30-35 ft-lb for U-bolt clamps. Over tightening will result in the clamps breaking and will NOT be warranted by MagnaFlow.

MAGNAFLOW: 1901 Corporate Centre Dr - Oceanside, CA 92056 | 1(800)990-0905

Technical Support: 1(800) 959-9226 | Email: [moreinfo@magnaflow.com](mailto:moreinfo@magnaflow.com)

## INSTALLATION INSTRUCTIONS



**Step 1:** Before removing the OEM exhaust system you will need to unplug the electrical connectors for both exhaust control valves. These are located on the vehicles tail pipes.



**Step 2:** Begin removing the OEM exhaust system by loosening the clamps located in front of the resonator. Next working front to rear extract the hangers from the rubber insulators and remove the OEM system. Retain insulators and clamps as they will be used to install the new system. Remove actuators from OEM exhaust and install on new rear muffler assemblies. Reuse OEM fasteners, heat shield and spring.

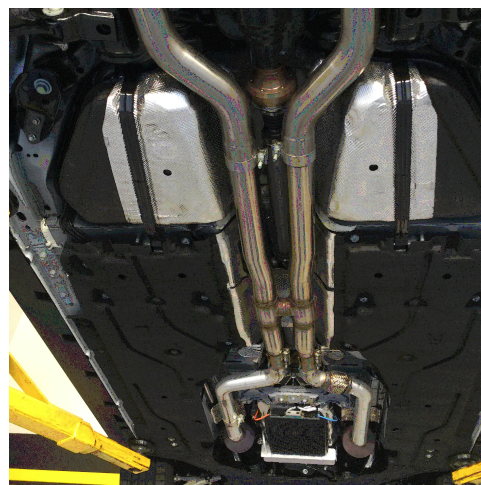

**Step 3:** Begin installation of the new system by loosely attaching the H-Pipe Assembly to the outlets using the OEM clamps. Leave all clamps loose until final adjustment.

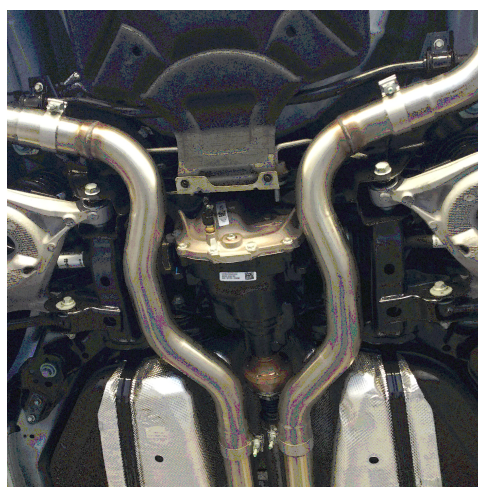

**Step 4:** Next attach the Mid Pipe Assemblies to the H-Pipe using the supplied 3.00" clamps and fitting the hangers into the rubber insulators.

## INSTALLATION INSTRUCTIONS



**Step 5:** Finish the initial installation by fitting the Muffler Assemblies onto the Mid pipe Assemblies using the supplied 3.00" clamps and inserting the hangers into the rubber insulators.

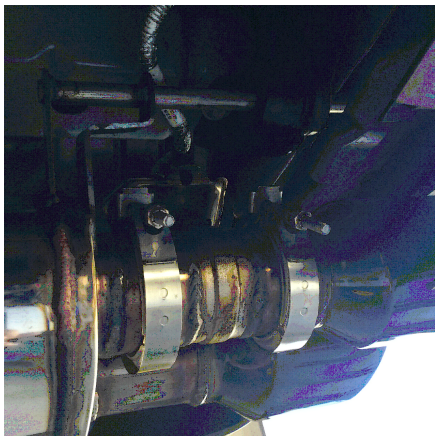

**Step 6:** Re-connect the wiring harness plugs to the Valve motors and wire mounting bracket.



**Step 7:** Once a final position has been chosen for the new exhaust system, evenly tighten all clamps from front to rear using the torque specifications on page one of these instructions. Inspect all fasteners after 25-50 miles for operation and re-tighten if necessary.