

MSD INSTALLATION INSTRUCTIONS

MSD Pro Mag 12 LT Chevrolet, PN 7908, PN 79081*, PN 79082*, PN 79083 Ford, PN 7915 and PN 79153

ONLINE PRODUCT REGISTRATION: Register your MSD product online. Registering your product will help if there is ever a warranty issue with your product and helps the MSD R&D team create new products that you ask for! Go to www.msperformance.com/registration.

Parts Included:

1 - Pro Mag Lt	1 - Flat Washer
1 - Billet Clamp	1 - Nut
1 - Set Screw	2 - O-rings (PN 7908 and PN 79083 only)
1 - Lock Washer	

⚠ WARNING * MSD Pro Mag 12 LT PN 79081 and PN 79082 are designed to work in RAISED CAM ENGINE BLOCKS using a DRY SUMP OILING SYSTEM only. They will work in engine blocks with 50mm, 55mm and 60mm cam tunnels. Installation of PN 79081 or PN 79082 in any other application is not recommended and can result in engine damage.

If you have any questions or your engine does not fit this criteria please contact MSD Technical Support at (915) 855-7123 for information and the correct part number for your application.

1. Install the set screw into the intake manifold or engine block.
2. Install the magneto into the engine. On Chevrolet engines, position it so the hold down clamp will align with the housing's anti-rotation collar.
3. Install the billet clamp over the set screw and on to the collar of the magneto. Put the flat washer, lock washer and the nut onto the stud and tighten the assembly.

- Note:** On Chevrolet applications, it is recommended to locate the wiring harness of the generator towards the left side injector stack (Figure 1). This also puts the timing indicator of the magneto in a position that should be easy to view. Also position the band clamp's retaining screw so it points to the left and is in the back of the magneto, close to the firewall. On Ford and Chrysler engines, rotate the base until the pointer is easy to view.
4. Locate which cap terminal is going to be the number one cylinder. Mark on the housing this location then remove the cap (Figure 2).

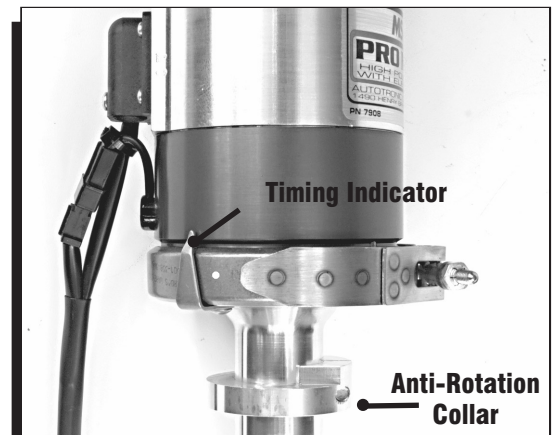

Figure 1 Positioning the Chevrolet Generator.

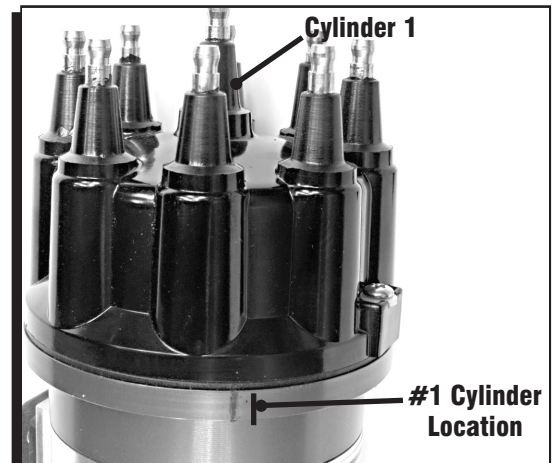

Figure 2 Marking the Number One Location.

5. Loosen the band clamp and position the generator so the rotor tip is just leading into the number one cylinder mark (from step 4) indicating the number one cylinder (Figure 3). This will put the timing approximately 2°-3° within TDC or where you have the timing set.
Note: Always verify timing with a timing light.

Chevy/Chrysler	-	Clockwise Rotation
Ford	-	Counterclockwise Rotation



Figure 3 Positioning the Rotor Tip.

6. Install the cap and spark plug wires.

Recommendation: It is recommended on Chevrolet applications to put the number one cylinder in the position shown in Figure 4. The custom wire sets MSD offers are designed for this setup.

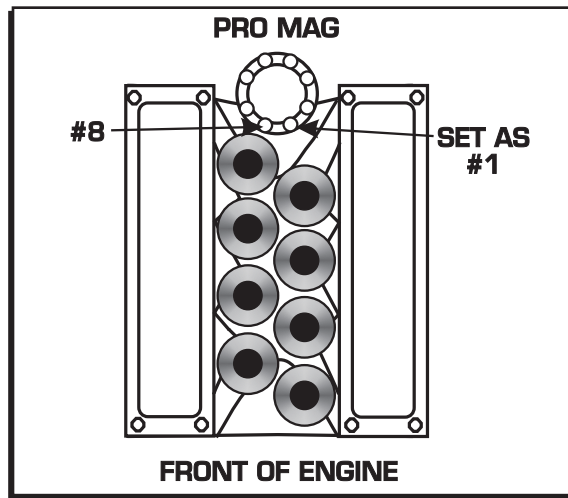

Figure 4 Recommended Chevrolet Installation Position.

7. **Chevrolet PN 7908 and PN 79083 only:** Install the gasket and apply a liberal amount of the supplied lubricant to the distributor gear and O-rings. (The supplied O-rings can **only** be used if the block has been modified as shown in Figure 5.)

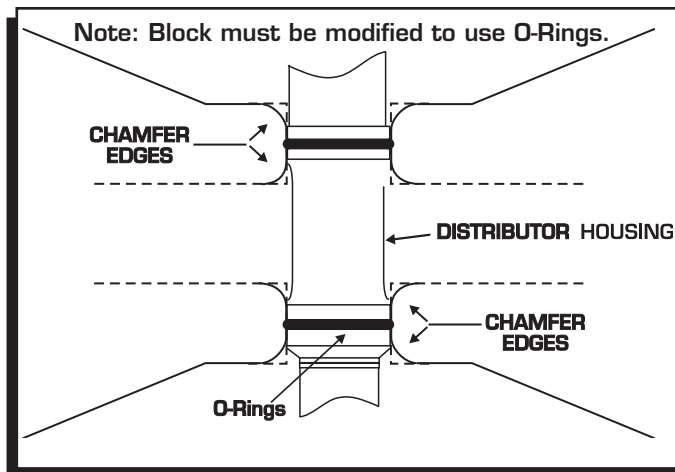

Figure 5 Chevy Blocks must be modified to accept O-rings.

TIMING TAPE

There is a timing tape supplied with the Pro Mag. Once the timing is set and verified, apply the tape to the side of the generator aligning it with the pointer on the magneto base (Figure 6). This is not meant for exact timing changes, but will help for a guide when tuning.



Figure 6 Applying the Timing Tape.

WIRING

Figure 7 show the wiring of the Pro Mag system.

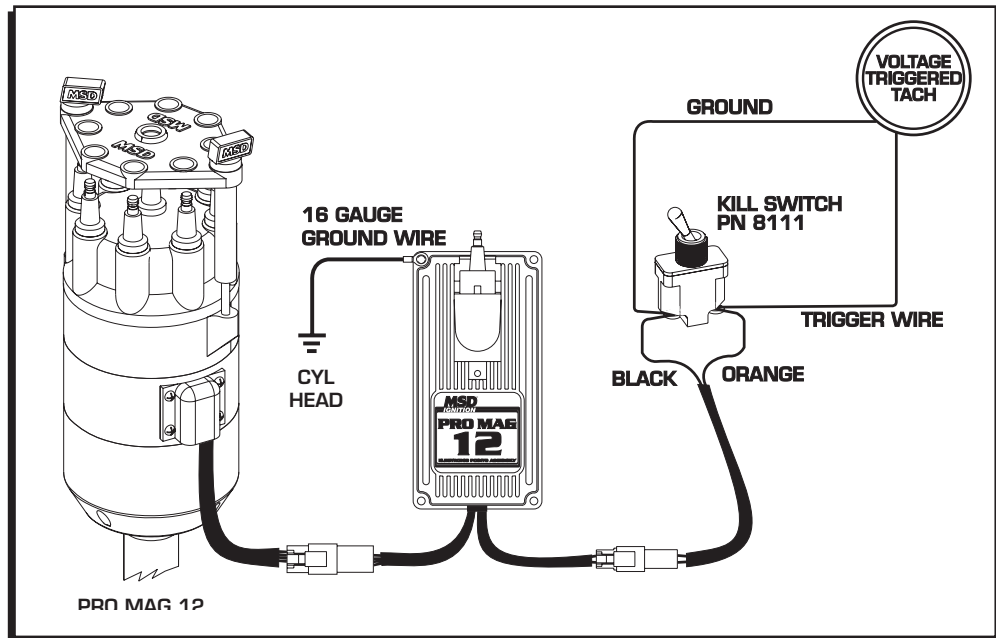

Figure 7 Wiring the Pro Mag 12 Lt.

Maintenance Parts		
Cap/Rotor	-	PN 7919 Red / PN 79193 Black
Gears:		
Chevrolet	-	PN 8472 (.006" Oversized)
Ford	-	PN 8585
Kill Switch	-	PN 8111
Pro-Billet Clamps:		
Chevrolet	-	PN 8110
Ford	-	PN 8010
Band Clamp	-	PN 8148

TECH NOTES

Service

In case of malfunction, this MSD component will be repaired free of charge according to the terms of the warranty. When returning MSD components for warranty service, **Proof of Purchase** must be supplied for verification. After the warranty period has expired, repair service is based on a minimum and maximum fee.

All returns must have a Return Material Authorization (RMA) number issued to them before being returned. To obtain an RMA number please contact MSD Customer Service at 1 (888) MSD-7859 or visit our website at www.msdpower.com/rma to automatically obtain a number and shipping information.

When returning the unit for repair, leave all wires at the length in which you have them installed. Be sure to include a detailed account of any problems experienced, and what components and accessories are installed on the vehicle. The repaired unit will be returned as soon as possible using Ground shipping methods (ground shipping is covered by warranty). For more information, call MSD at (915) 855-7123. MSD technicians are available from 7:00 a.m. to 5:00 p.m. Monday - Friday (mountain time).

Limited Warranty

MSD warrants this product to be free from defects in material and workmanship under its intended normal use*, when properly installed and purchased from an authorized MSD dealer, for a period of one year from the date of the original purchase. This warranty is void for any products purchased through auction websites. If found to be defective as mentioned above, it will be repaired or replaced at the option of MSD. Any item that is covered under this warranty will be returned free of charge using Ground shipping methods.

This shall constitute the sole remedy of the purchaser and the sole liability of MSD. To the extent permitted by law, the foregoing is exclusive and in lieu of all other warranties or representation whether expressed or implied, including any implied warranty of merchantability or fitness. In no event shall MSD or its suppliers be liable for special or consequential damages.

*Intended normal use means that this item is being used as was originally intended and for the original application as sold by MSD. Any modifications to this item or if it is used on an application other than what MSD markets the product, the warranty will be void. It is the sole responsibility of the customer to determine that this item will work for the application they are intending. MSD will accept no liability for custom applications.