

MSD INSTALLATION INSTRUCTIONS

MSD Cap and Rotor for GM LT-1 Engines 1995-1997 PN 84811

ONLINE PRODUCT REGISTRATION: Register your MSD product online. Registering your product will help if there is ever a warranty issue with your product and helps the MSD R&D team create new products that you ask for! Go to www.msperformance.com/registration.

Parts Included:

1 - Cap	4 - 3.5mm x 6mm Phillips Screws
1 - Rotor	1 - 8-32 x 1.125 Phillips Screw
1 - Isolator	1 - Clamp-Block
2 - Rotor Screws	1 - Removal Tool
2 - Seals	

IMPORTANT: Due to the number of applications and years that the LT-1 Cap and Rotor are used on, it is highly recommended to have the Service Manual for your vehicle during this installation.

DISASSEMBLY

1. Disconnect the negative battery cable.
2. Locate the radiator petcock and drain the coolant from the system.
3. Disconnect the MAF and IAC sensors. Remove the air intake ductwork and the MAF sensor.
4. Once the coolant is drained, remove the upper radiator hose from the thermostat housing.
5. Loosen the three bolts that secure the crankshaft pulley/hub assembly. Do not remove them entirely at this time.
6. Remove the accessory drive belt by moving the spring loaded idler pulley. Use caution as this pulley is spring loaded! The belt will slide off the pulley system and the idler pulley will settle beyond its installed position.
7. Once the belt is removed, proceed with removing the pulley from the crankshaft hub by pulling the three retaining bolts.
8. It may be necessary to remove the cooling fan. This is done by removing the four bolts and disconnecting the wiring connection.
9. Disconnect the air pump power wires and remove the air pump from its mounting brackets.
10. Disconnect the coolant temperature wiring sensor located on the water pump.
11. Loosen the lower radiator hose clamp and the two heater hose clamps at the water pump. Coolant will generally still pour out of the hoses and water pump.
12. To remove the water pump, the power steering pump may need to be removed. With a shorter extension, the water pump bolt should be able to be accessed. There are six water pump bolts. Once again, more coolant may spill out.
13. At this point, you should be able to access the distributor cap! Mark the location of each spark plug wire before removing them.
14. Remove the vacuum lines (if equipped) and the distributor

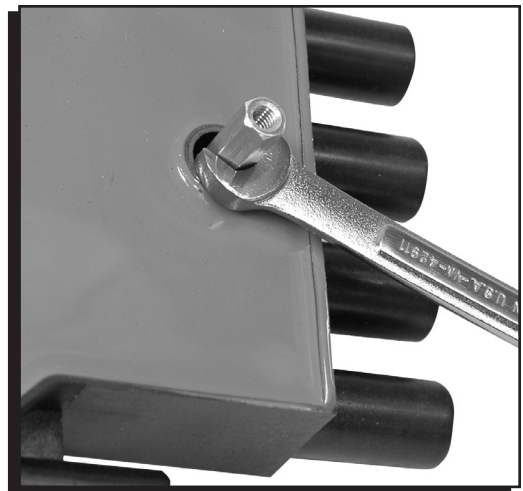

Figure 1 Removing the Original Cap.

connector.

15. Using the supplied special tool and a 1/4" wrench, remove the four screws that hold the distributor cap to the engine and pull the cap off (Figure 1).
16. Remove the two rotor screws and pull the rotor off. At this time, the isolator assembly will slide off the housing.

INSTALLATION

1. Locate and install the distributor-to-isolator seal then position the isolator in place on the distributor (Figure 2).
2. Install the new rotor with the supplied hardware. The rotor only installs one way. Make sure it sits squarely on the shaft.

Note: It is recommended to use a threadlocker like Loctite Blue on the two rotor screws.

3. Make sure that the Isolator-to-Cap seal is installed on the isolator, then install the cap using the supplied Phillips head screws (Figure 3).
4. Locate four metric Phillips screws that retain the cap assembly. There is also a standard, slightly larger and longer Phillips screw. This screw is used with the Clamp-Block that goes in the cap tab located between the wiring harness and the coil wire tower (Figure 4).
5. Note that the Clamp-Block has two different thicknesses (Figure 5). Some distributor housings have a machined surface while others are cast. Determine which side works best in your application to secure the top mount of the cap. Once the direction is achieved, slide the Clamp-Block into position and screw the standard Phillips screw into position (Figure 5).
6. Connect the distributor connector followed by the coil wire and spark plug wires. Ensure that each wire is in the correct location (Figure 6).
7. The distributor is assembled. Reinstall all of the components in the reverse order. It is recommended to follow along with your vehicle's service manual.



Figure 2 Installing the Distributor-to-Isolator Seal.

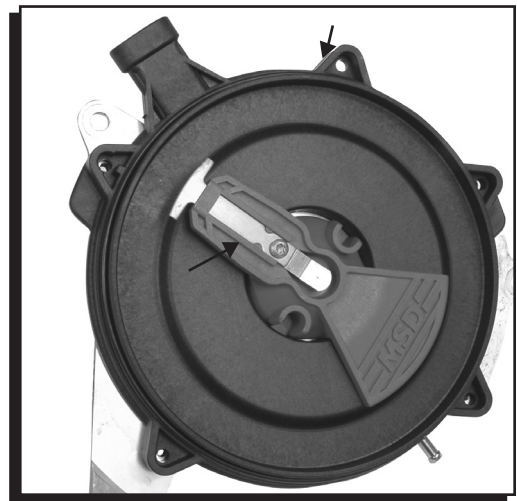

Figure 3 The Isolator-to-Cap Seal.

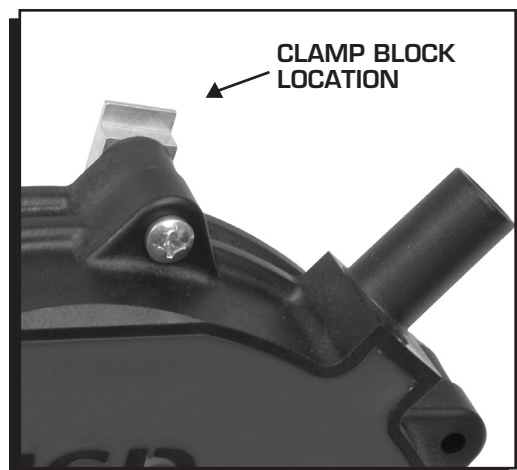

Figure 4 Clamp-Block Mounting Boss.

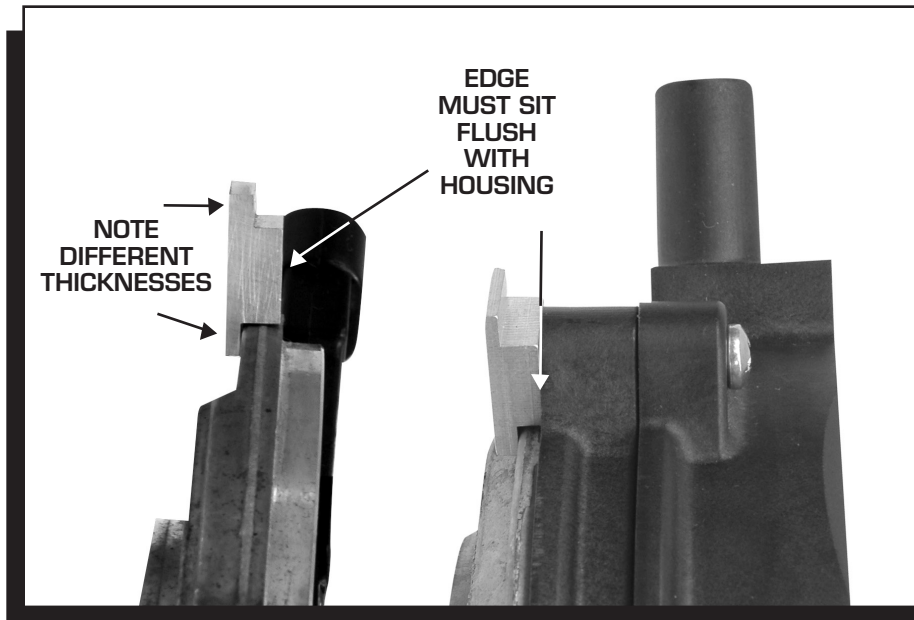

Figure 5 Installing the Clamp-Block.

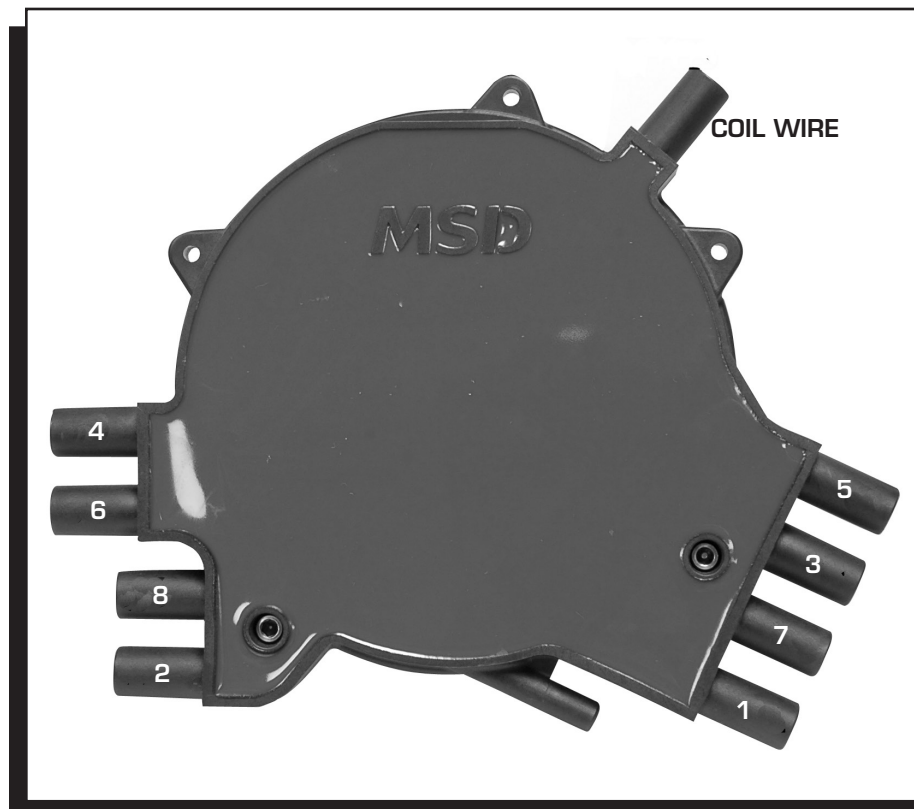

Figure 6 Spark Plug Wire Location.

