

INSTALLATION INSTRUCTIONS

MSD 2-Step Launch Control for GM GEN V LT1 Series Engines PN 87331

ONLINE PRODUCT REGISTRATION: Register your MSD product online. Registering your product will help if there is ever a warranty issue with your product and helps the MSD R&D team create new products that you ask for! Go to www.msperformance.com/registration.

Parts Included:

1 - 2-Step Launch Control

1 - 1-Pin Wire Harnesses

Note: The 2-Step Launch Control is designed as a momentary low-rpm limiter. It will not provide nor modify any overrev protection.

This MSD 2-Step Launch Control is designed for GM GEN V LT Series Engines with Coil-per-Cylinder ignitions. The 2-Step Control will provide consistent launches and quick 60-foot times. RPM adjustments are made via two rotary switches located on the harness side of the unit. The adjustment range is from 1,000 - 10,900 rpm, in 100 and 1000 rpm increments. The LED will illuminate when the launch rev limit is active.

Note: It is recommended to have the service manual for your vehicle.

Note: The engine rpm must drop more than one third of the set launch limit in order to activate. For example, if the launch limit is set at 3,000 rpm, the engine speed must drop below 2,000 rpm in order for the launch limit to become active (one third of 3,000 rpm is a 1,000 rpm drop).

Caution: Keeping the engine on a lower rpm limit may cause the Check Engine light to come on and could potentially damage the catalytic converter.

MOUNTING

The 2-Step Control can be mounted in any position but keep in mind to mount it so the rotary dials are accessible for adjustments. Hardware is supplied for mounting. Before mounting the unit, confirm that the wiring harnesses reach their connections.

ACTIVATION WIRES

BLUE	When grounded, the launch feature will be active.
BLUE/WHITE	When switched to 12 volts, the launch feature will be active.

LED

The built-in LED will illuminate when the 2-Step Launch Control is activated.

CONNECT THE ACTIVATION WIRE

The launch rpm limit can be activated through a ground or a 12 volt source.

Ground: Switch the Blue wire to ground to activate the launch limit.

12 volts: Connect the White/Blue wire to 12 volts to activate the launch limit.

The LT 2-Step has a built-in rpm drop circuit that prevents the low rpm limit from activating during gear shifts (when connected through the clutch switch). In order for the limit to activate, it must see an rpm drop of more than 1/3 the set amount. For example, if the limit is set at 3,000 rpm, the limiter will not activate unless it sees more than a 1,000 rpm drop.

BLUE - ACTIVATED WHEN GROUNDED.
BLUE/WHITE - ACTIVATED WITH 12 VOLTS.

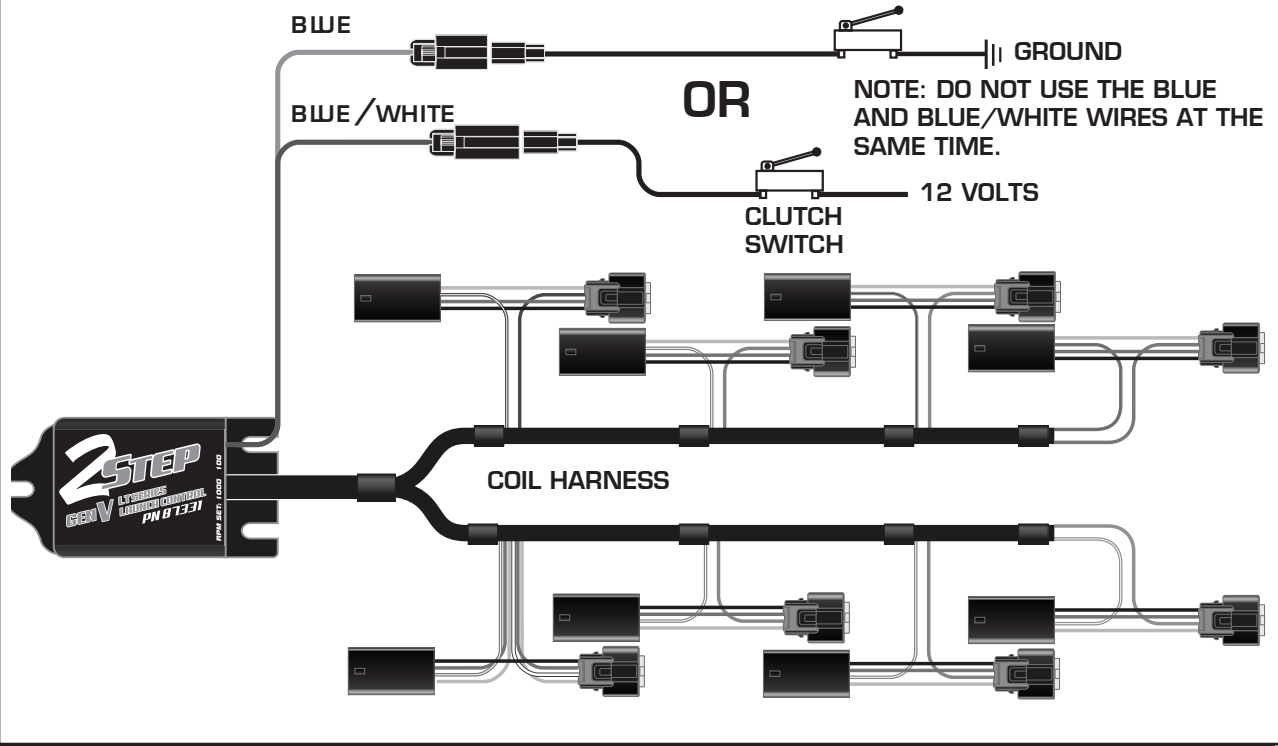

Figure 1 Wiring the Launch Activation Wire.

Service

In case of malfunction, this MSD component will be repaired free of charge according to the terms of the warranty. When returning MSD components for warranty service, **Proof of Purchase** must be supplied for verification. After the warranty period has expired, repair service is based on a minimum and maximum fee.

All returns must have a Return Material Authorization (RMA) number issued to them before being returned. To obtain an RMA number please contact MSD Customer Service at 1 (888) MSD-7859 or visit our website at www.msperformance.com/rma to automatically obtain a number and shipping information.

When returning the unit for repair, leave all wires at the length in which you have them installed. Be sure to include a detailed account of any problems experienced, and what components and accessories are installed on the vehicle. The repaired unit will be returned as soon as possible using Ground shipping methods (ground shipping is covered by warranty). For more information, call MSD at (915) 855-7123. MSD technicians are available from 7:00 a.m. to 5:00 p.m. Monday - Friday (mountain time).

Limited Warranty

MSD warrants this product to be free from defects in material and workmanship under its intended normal use*, when properly installed and purchased from an authorized MSD dealer, for a period of one year from the date of the original purchase. This warranty is void for any products purchased through auction websites. If found to be defective as mentioned above, it will be repaired or replaced at the option of MSD. Any item that is covered under this warranty will be returned free of charge using Ground shipping methods.

This shall constitute the sole remedy of the purchaser and the sole liability of MSD. To the extent permitted by law, the foregoing is exclusive and in lieu of all other warranties or representation whether expressed or implied, including any implied warranty of merchantability or fitness. In no event shall MSD or its suppliers be liable for special or consequential damages.

*Intended normal use means that this item is being used as was originally intended and for the original application as sold by MSD. Any modifications to this item or if it is used on an application other than what MSD markets the product, the warranty will be void. It is the sole responsibility of the customer to determine that this item will work for the application they are intending. MSD will accept no liability for custom applications.