



I-SHEET PART NUMBER: INST-00294  
 PART NUMBER: **219416722**  
 PRODUCT: **HOOP STEP**  
 APPLICATION: **RAM 1500 QC**

HARDWARE DESCRIPTION		QTY.
FLNT-00696X	M8-1.25 CLASS 8 SERRATED FLANGE NUT	18
FDRW-00736X	M8 FENDER WASHER	18
	10MM flanged nut	12
	10MM Carriage bolt	12



PARTS INCLUDED	QTY
DRIVER SIDE STEP	1
PASSENGER SIDE STEP	1
Mounting Brackets	12

Identify driver side step.

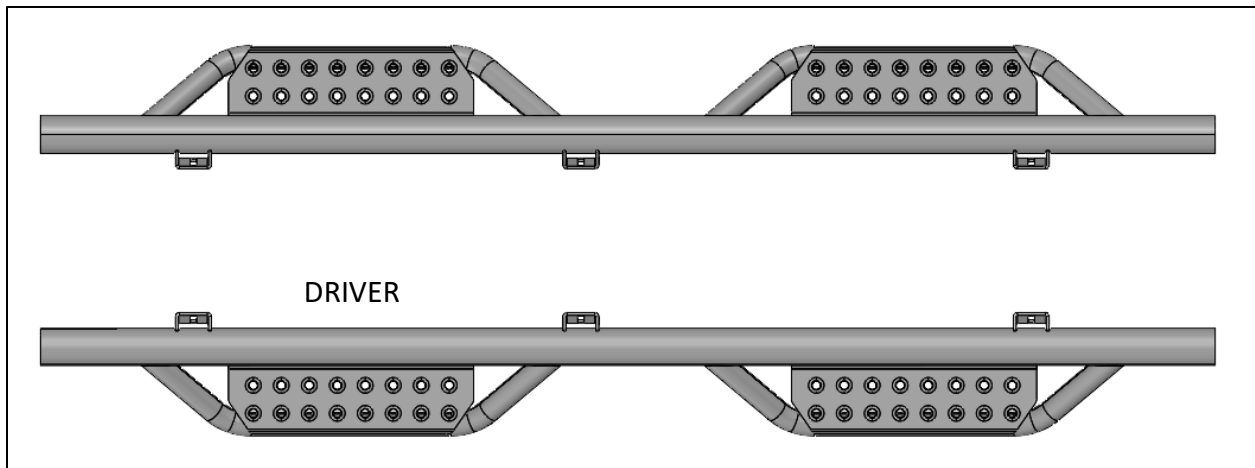

**Step 1:** Install the (x6) mounting brackets to each attachment point on the main tube and leave loose for now. ***Note the bracket orientation. The front bracket bends towards the front of the vehicle.***

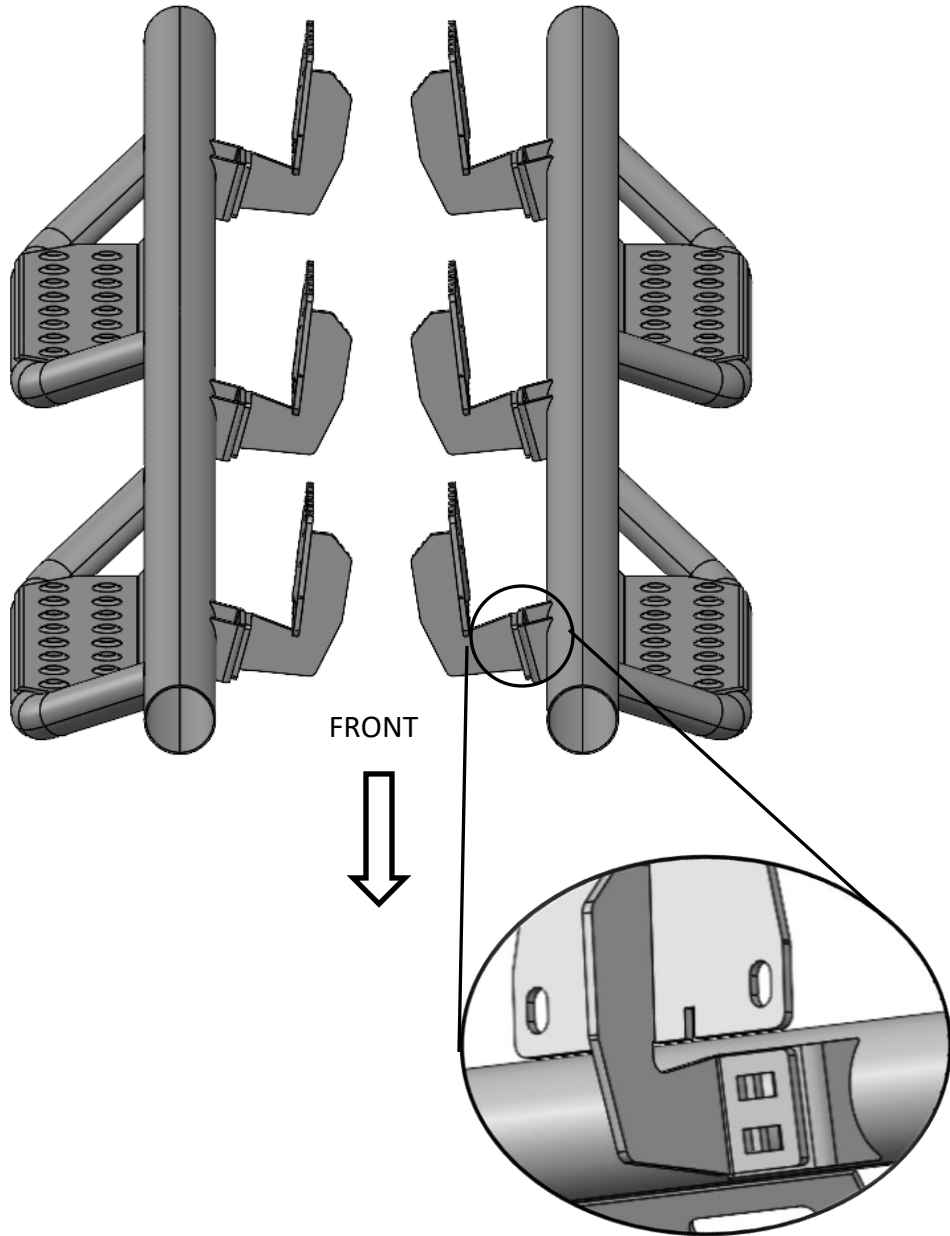

**Step 2:** Starting with the driver side, remove any steps and old hardware from the vehicle.



**Step 3:** On the inside rocker panel there will be three attachment points consisting of three 8mm studs coming out from the panel. These studs may be covered in paint and will need to be cleaned before the installation.



**Step 4:** An additional person is recommended for this step. Carefully install the Hoop step to the three factory attachment points using the provided M8 flanged hex nuts. Leave finger tight for now.



**Step 5:** After final adjustment, tighten (x3) bracket to (20 ft./lbs of torque.)

**Step 6:** Next, tighten (x3) mounting brackets at the main tube ( 20-25 ft./lbs torque.)

**Step 7:** Re-peat steps 1-6 for passenger side.

