

HARDWARE DESCRIPTION		QTY.
HWKT-03054X		
FLBW-00894X	M8-1.25 X 30MM CLASS 8.8 FLANGE CAP SCREW W/WASHER	12
	10mm carriage bolt	6
	10mm flanged nut	6

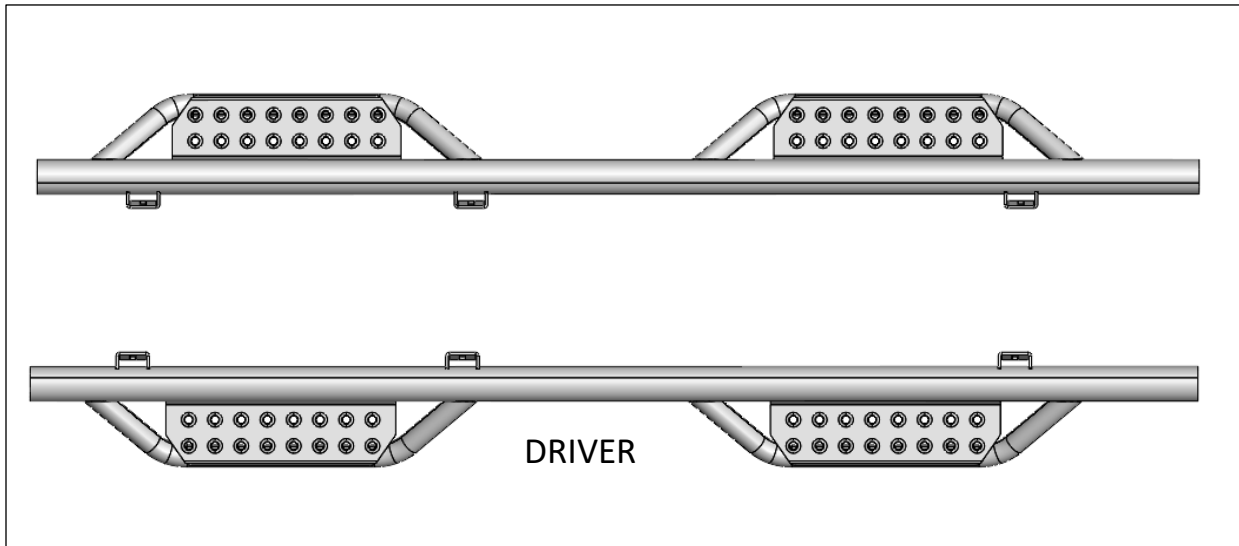

PARTS INCLUDED		QTY
DRIVER SIDE		1
PASSENGER SIDE		1
Mounting Bracket		6

Step 1: Locate the driver side step rail.



Step 2: Install the (x6) mounting brackets to each attachment point on the main tube using the supplied M10x25 carriage bolts, M10 hex nuts and leave loose for now. **NOTE Bracket orientation. The bend faces towards the front on driver side and towards rear on passenger side.**

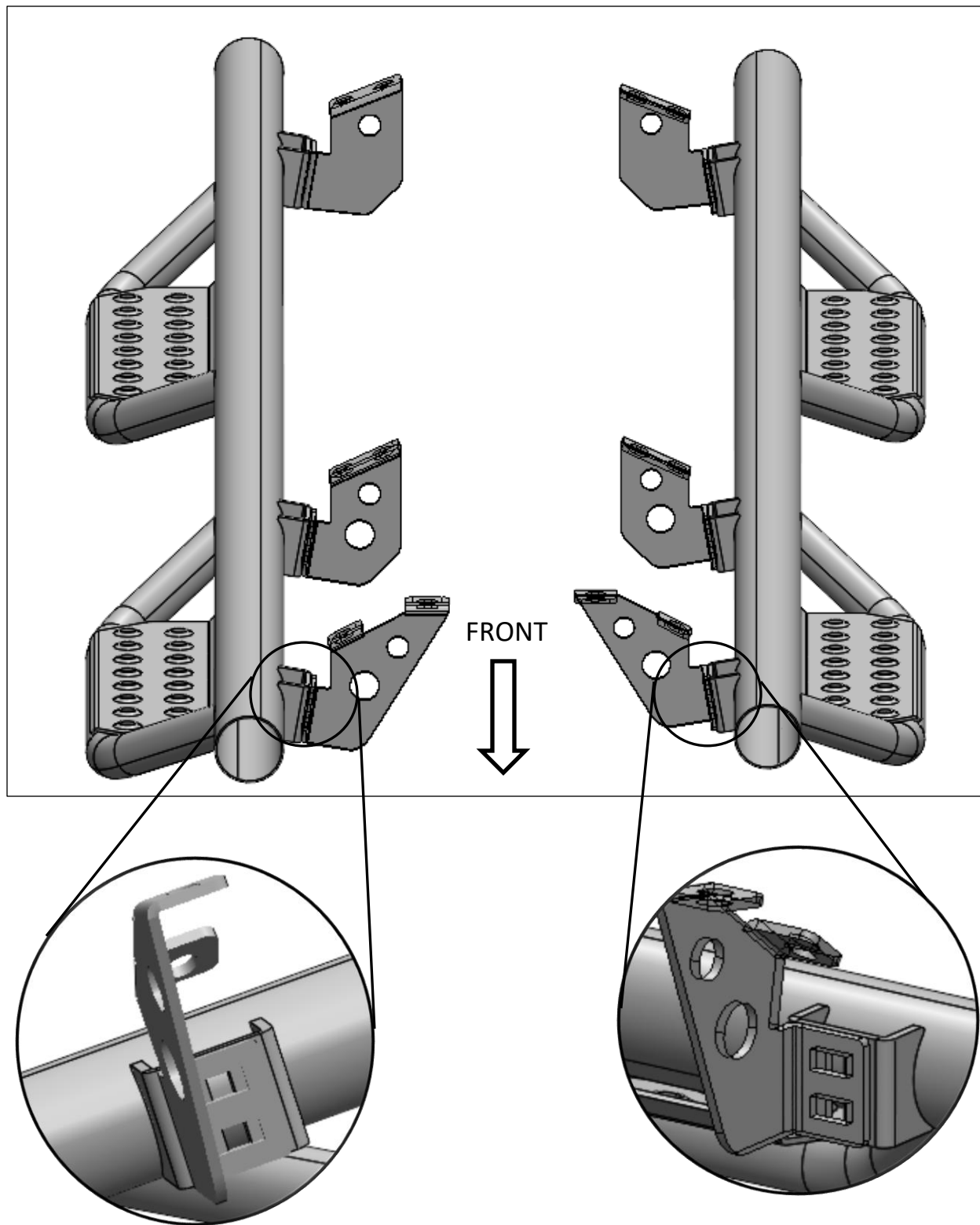

Step 3: Remove any factory hardware and discard.

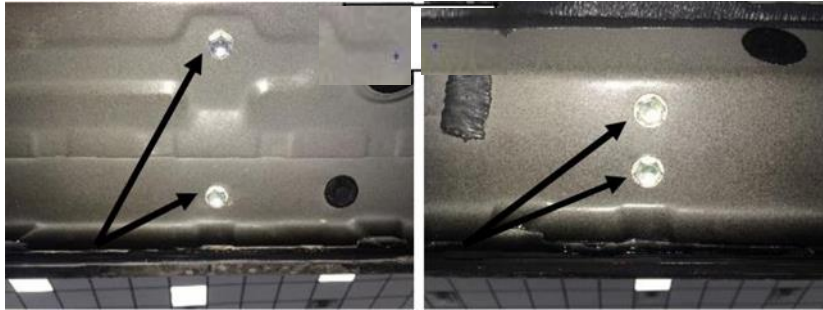

Step 4: Position step up to the body of the vehicle and align the brackets up with the factory mounting locations.

Step 5: Beginning with the center bracket, start one of the M8x30mm hex bolts into the factory bolt location and leave loose. Start the second M8x30mm hex bolt in the same bracket and loosely tighten.

Step 6: Start all remaining M8x30mm hex bolts in each bracket and leave loose.

Step 7: After final positioning, start at the rear of the vehicle and tighten the lower portion of the bracket to 15-20 ft./lbs of torque. Continue this until all of the lower fasteners have been tightened, then move to the top bolts and repeat the process.

Step 8: Next, tighten all brackets at the main tube. (20-25 ft./lbs. torque).

Step 9: Repeat steps 2-7 for the other side.

