

| HARDWARE DESCRIPTION | | QTY. |
|----------------------|--|------|
| HWKT- 05307X | | |
| CARB-00680X | 3/8"-16 X 1-1/2" GRADE 5 CARRIAGE BOLT | 12 |
| HXNT-00717X | 3/8"-16 HEX NUT | 12 |
| FLTW-00663X | 3/8" USS FLAT WASHER | 12 |



| PARTS INCLUDED | | QTY. |
|----------------|--|------|
| DRIVER SIDE | | 1 |
| PASSENGER SIDE | | 1 |

N-FAB NERF STEP SYSTEM

STEP 1: Identify driver side step.

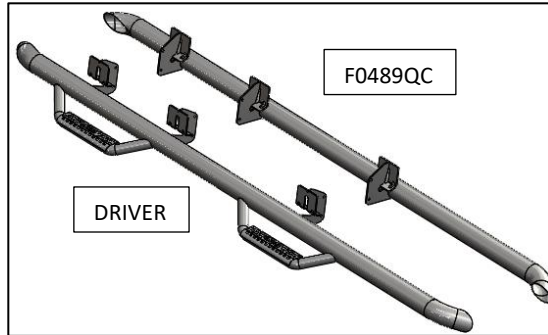
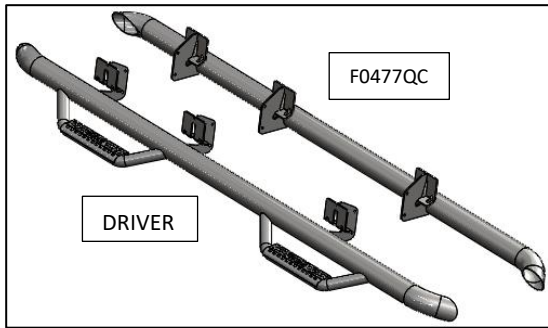
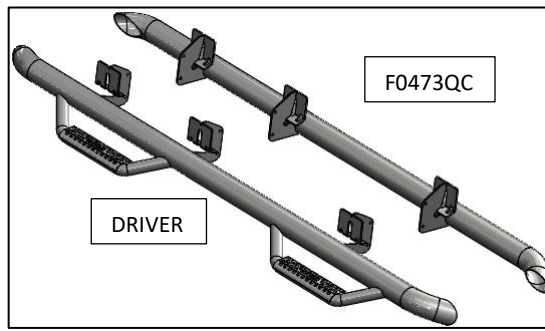
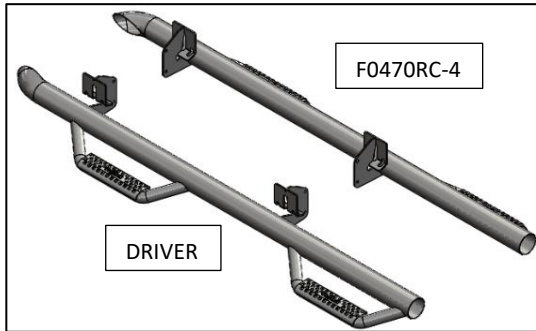

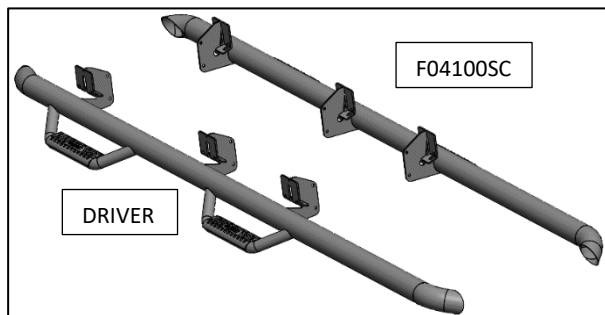
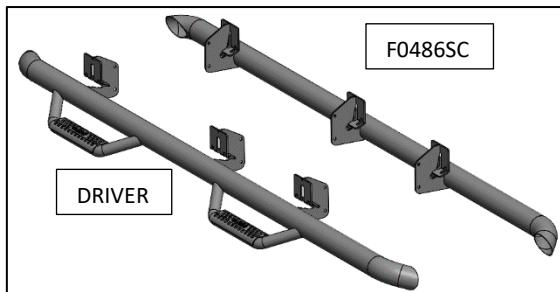
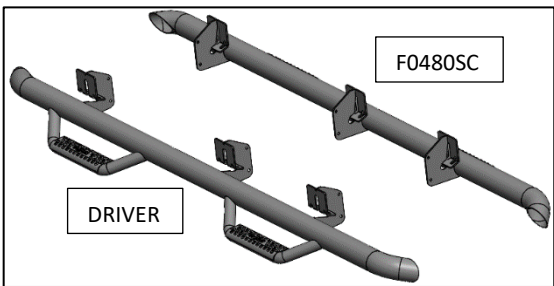
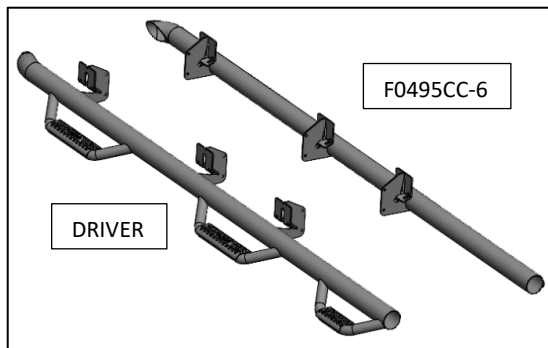
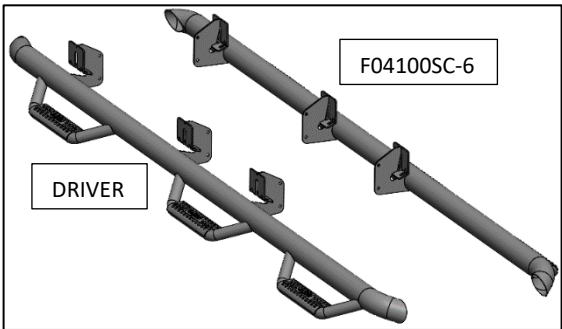
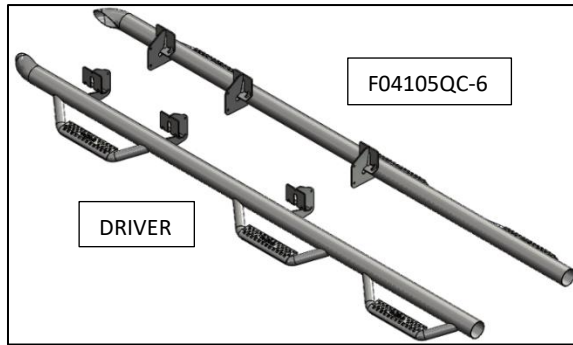
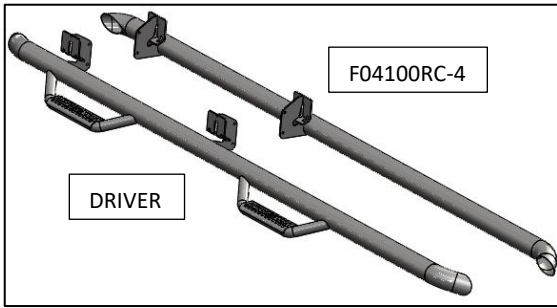
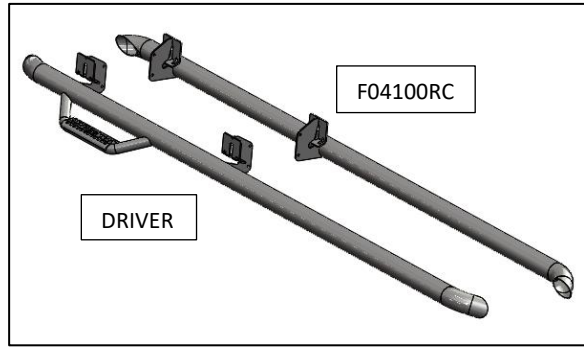
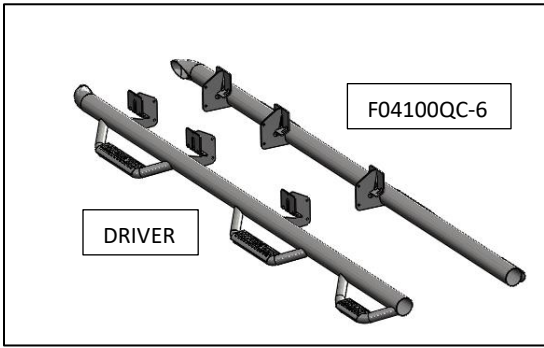

Step 2: Install nerf-step with the mounting bracket on top of the pinch weld aligning with the factory holes.

Step 3: Install the supplied 3/8" x 3/4" carriage bolts, 3/8" washer and 3/8" nuts in each mounting location with the bolt starting from the under-side and hand tighten.



Step 4: After final adjustment, tighten all hardware to 17-20 ft./lbs. of torque.

Step 5: Repeat with passenger side.