



I-SHEET PART NUMBER: INST-00237
 PART NUMBER: **NBT07CC-TX**
 PRODUCT: **NERF BOARD**
 APPLICATION: **07-21 TUNDRA CC**

HWKT-03054X		QTY
FLBW-00894X	M8-1.25 X 30MM FLANGE CAP SCREW W/WASHER	12

HWKT-09617X		QTY
BHCS-09591X	M6X16MM BUTTON HEAD CAP SCREW	24
FW-09601	M6 FLAT WASHER	24
BHCS-09603	M6 flanged nut	24
CARB-09609	3/8"-16X1" Gr 5 Steel Carriage Bolt	12
HXNT-09613	3/8"-16 HEX NUT	12
FW-09611	3/8" FLAT WASHER	12

PARTS INCLUDED	QTY
Driver Side Running Board	1
Passenger Side Running Board	1
Rocker panel brackets	6
Step Plate	4

ROAN

RUNNING BOARD



Step 1: Identify Driver Side Nerf Board.

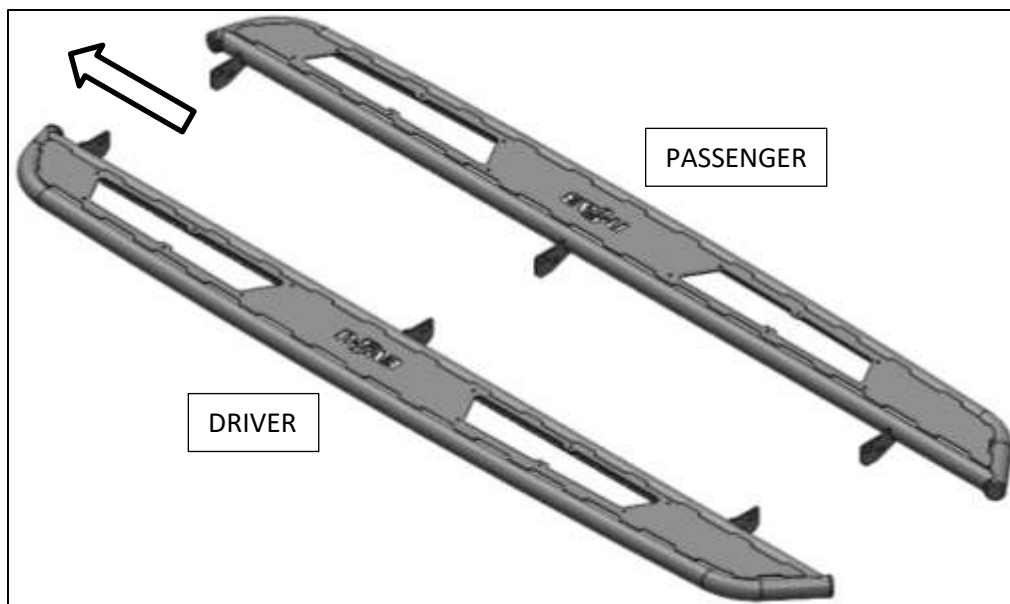

Step 2: Install the supplied step plate (x2) to each Running Board using the M6x20mm button head bolts, M6 nuts and M6 flat washer.

**** DO NOT OVER TIGHTEN ****

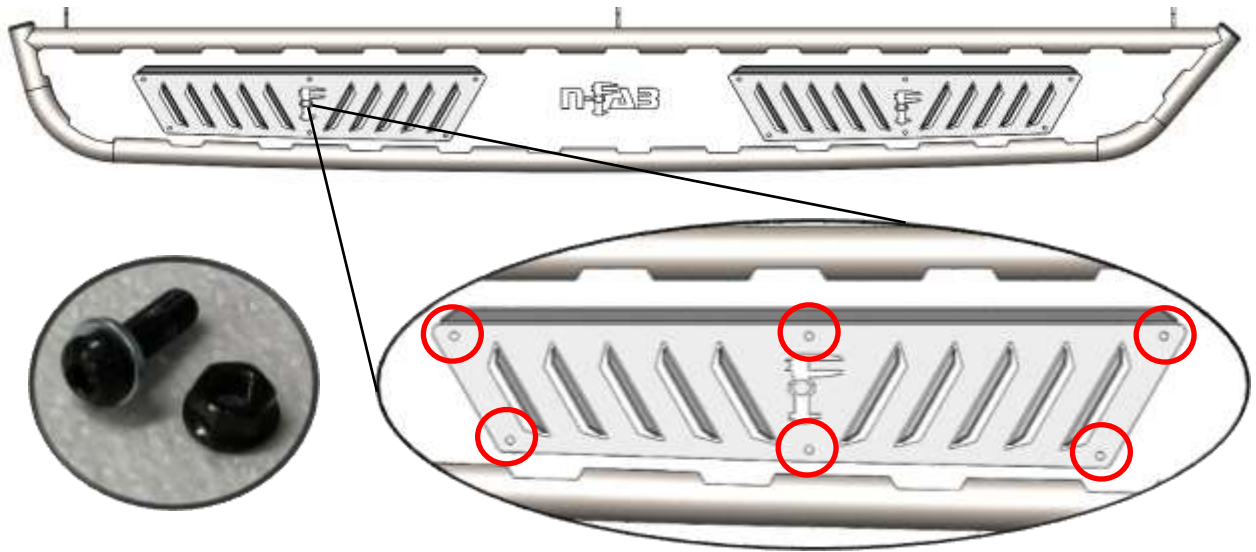

Step 3: Install the supplied rocker panel brackets (x6) to the attachments points located on the backside of the main tube (Driver/Passg) using the supplied 3/8" x 1" carriage bolts and 3/8" flanged nuts. Leave finger tight for now.

NOTE: BE SURE THE BEND DIRECTION OF EACH BRACKET IS CORRECT ON THE DRIVER AND PASSENGER Nerf Board.

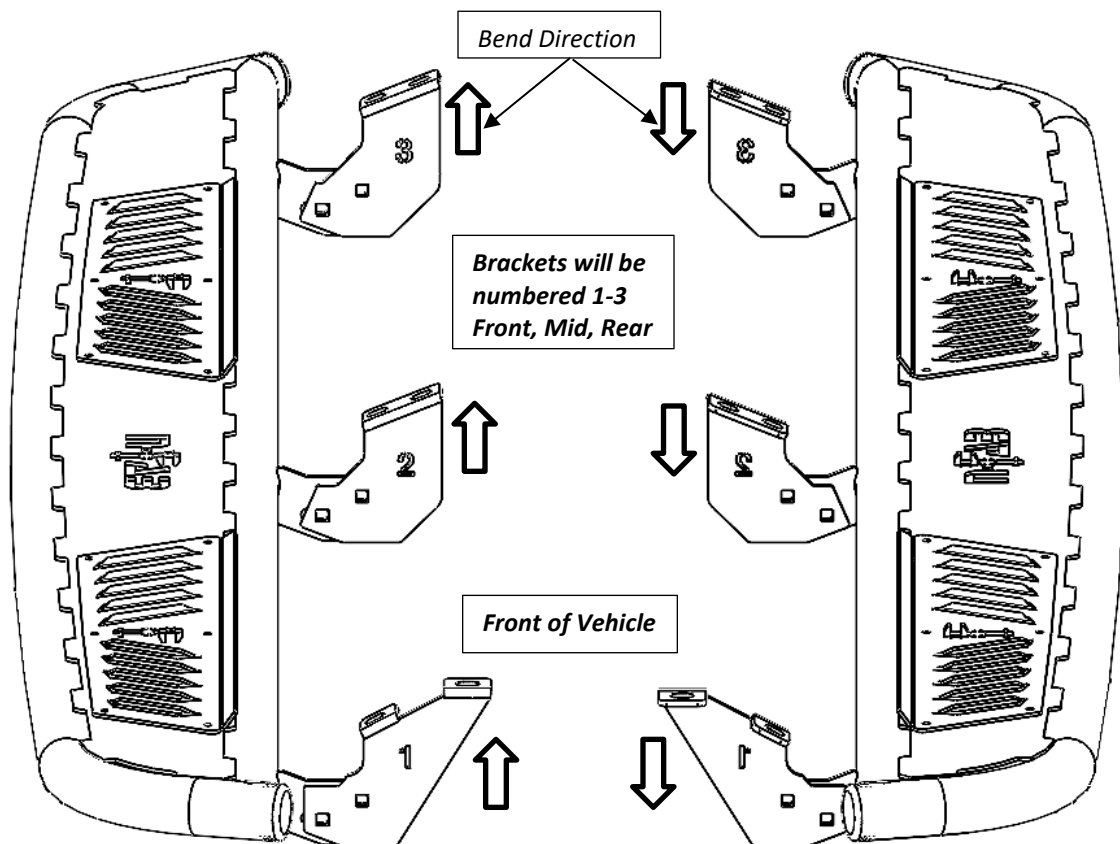



I-SHEET PART NUMBER: INST-00237
PART NUMBER: **NBT07CC-TX**
PRODUCT: **NERF BOARD**
APPLICATION: **07-21 TUNDRA CC**

Step 4: Remove any factory hardware and discard.

Step 5: Carefully raise the Nerf Board up and match the brackets with the factory mounting locations. Next, starting with the center bracket and using the supplied M8X30mm Hex cap with washer, start and leave loose.

Step 6: Start the remaining hardware with the front and rear bracket and then tighten (18-20 ft./lbs.)

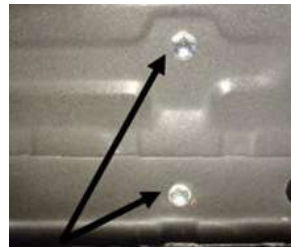

Step 7: There will be $\frac{1}{2}$ " of adjustment in the (x3) mounting bracket. Adjust to desired position and tighten to (20 ft./lbs).



Step 8: Repeat steps 4-7 for passenger side.