

# INSTALLATION INSTRUCTIONS

EQUIPMENT REQUIRED:

WIRING ACCESS LOCATION: SUV1, SUV2

DRILL BITS: NONE

HITCH REQUIRES 5/8" PIN AND CLIP IF STABILIZING PIN IS NOT INSTALLED.

WRENCHES: (TIGHTEN ALL FASTENERS WITH TORQUE WRENCH) 3/4, 7/8

VEHICLE

HITCH NO.

FORD EXPEDITION  
LINCOLN NAVIGATOR

51024  
44032

DO NOT EXCEED LOWER OF  
TOWING VEHICLE MFR'S RATINGS OR

HITCH TYPE ▼	MAX GROSS TRLR WT(LB)	MAX TONGUE WT(LB)
WEIGHT DISTRIBUTING	10,000	1000
WEIGHT CARRYING BALL MOUNT	5000	500

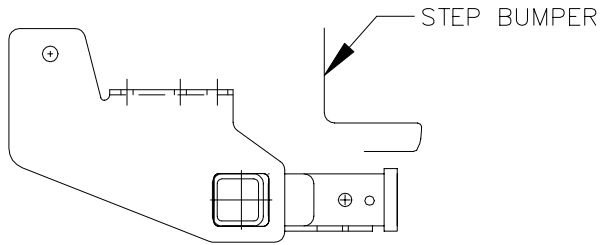

HITCH SHOWN INSTALLED IN  
PROPER POSITION

FRAME RAIL

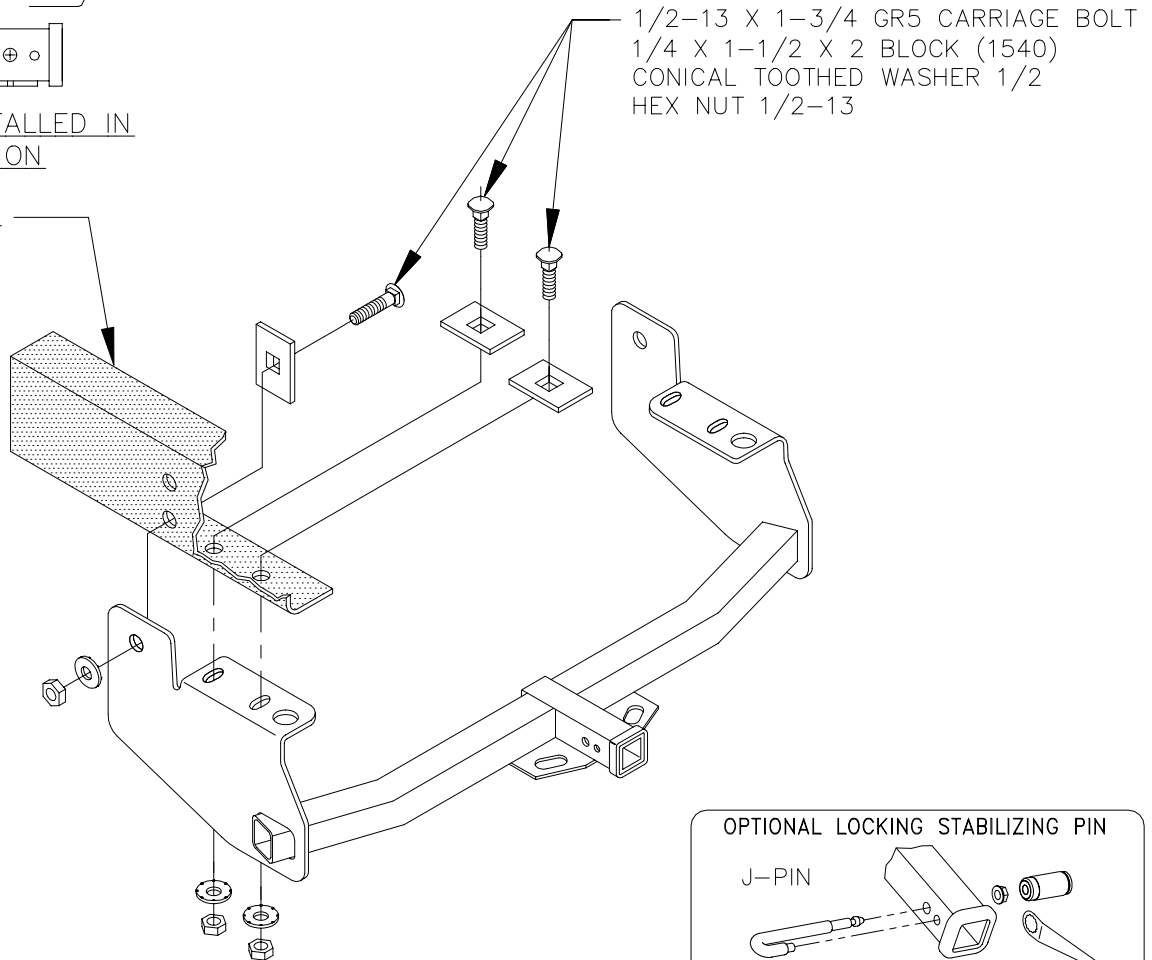

1/2-13 X 1-3/4 GR5 CARRIAGE BOLT  
1/4 X 1-1/2 X 2 BLOCK (1540)  
CONICAL TOOTHED WASHER 1/2  
HEX NUT 1/2-13

OPTIONAL LOCKING STABILIZING PIN

J-PIN

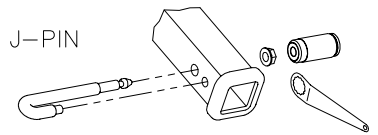

(Order Separately)

USES EXISTING HOLES IN FRAME – NO DRILLING REQUIRED.

1. SCRAPE WAX COATING OFF OF FRAME RAILS AROUND THE EIGHT ATTACHMENTS.
2. RAISE HITCH INTO POSITION WITH THE ATTACHMENTS IN THE VERTICAL PORTION OF THE BRACKET ON THE OUTSIDE OF THE FRAME.
3. LOOSELY INSTALL CARRIAGE BOLT AND BLOCK INTO REARMOIST ATTACHMENT HOLES IN EACH FRAME RAIL AS SHOWN ABOVE.
4. INSERT CARRIAGE BOLT AND BLOCK INTO FORWARD ATTACHMENT HOLE IN THE SIDE OF EACH FRAME RAIL AS SHOWN ABOVE AND TIGHTEN.
5. TIGHTEN REARMOIST BOLTS.

TIGHTEN 1/2 GR5 FASTENERS TO 75 LB.-FT.

THIS PRODUCT COMPLIES WITH SAFETY SPECIFICATIONS AND REQUIREMENTS FOR CONNECTING DEVICES AND TOWING SYSTEMS OF THE STATE OF NEW YORK AND V.E.S.C. REGULATION V-5.

APPROX WEIGHT (LB.)

53.5

FASTENER KIT

51024-051

NOTE: Check hitch frequently, making sure all fasteners and ball are properly tightened. If hitch is removed, plug all holes in trunk pan or other body panels to prevent entry of water and exhaust fumes. A hitch or ball which has been damaged should be removed and replaced. Observe safety precautions when working beneath a vehicle and wear eye protection. Follow car maker's specs for maximum trailer weight and tongue weight. Do not cut access or attachment holes with a torch.

**TOWING PRODUCTS**  
Plymouth, Michigan