



Sun Cap Plus Installation Instructions

For: Wrangler 1992 - 1995

Part Number: 41524

Do NOT INSTALL THIS PRODUCT ON ANY VEHICLE OTHER THAN THOSE LISTED ABOVE

This product is only designed for the vehicles listed above. Failure to install this product on the proper vehicle could cause injury to the vehicle occupants and damage to the product.

Important Note: If your vehicle has not been fitted with a factory soft top, it will be necessary to purchase a Windshield Channel Kit Number 45809-01 from your local distributor.

WARNING

This product is designed to enhance the appearance of the vehicle and to shield the occupants from ordinary weather conditions. Do not rely in any way on the components of this product to contain occupants within the vehicle, or to protect against injury or death in the event of an accident. This top will not protect the occupants from falling objects. Never operate vehicle in excess of manufacturer's specifications.

WEAR SEAT BELTS AT ALL TIMES

Read and follow, precisely, all installation instructions provided when installing top. Failure to do so may result in a poor fitting top and could place occupants of the vehicle in a potentially dangerous situation. After installing or reinstalling the top, check to make sure it has been properly installed.

Installation Tips

After completing the installation, keep these instructions for future reference. Before you begin installing this product, read all instructions thoroughly. Below are a few tips to make this installation easier.

For a smooth fit:

For ease in installation, this product should be installed at temperatures above 72° F. Below this temperature, the fabric may contract an inch or more, making it difficult to fit to the vehicle.

It is normal for the fabric to contract and wrinkle when stored in the shipping carton. Within a few days after the installation, the fabric will relax and the wrinkles will disappear.

Step One

Locate the Sun Cap Plus and orient it on the vehicle.
Drape it over the sport bar and insert the front of the Sun Cap Plus into windshield channel.

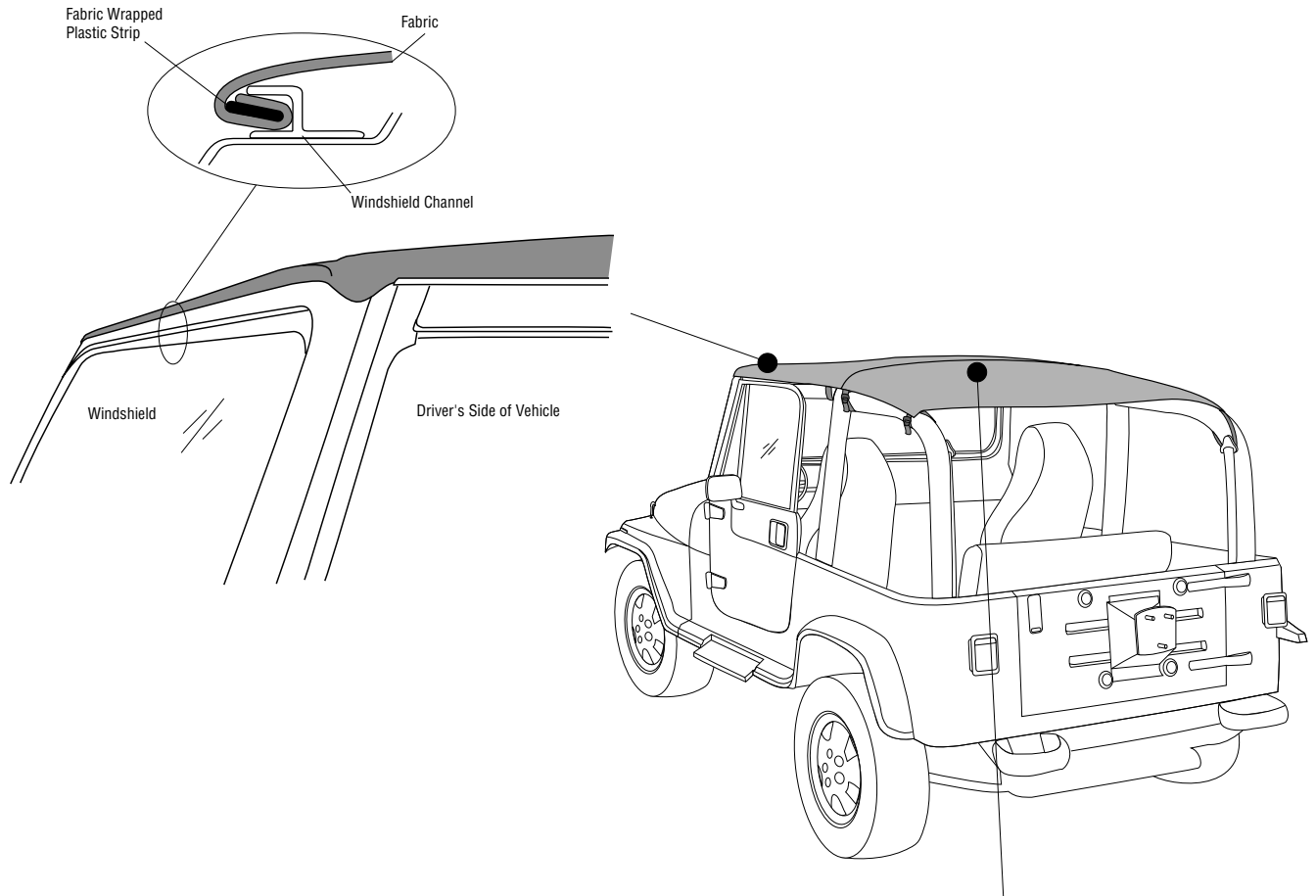

Step Two

Locate the long web strap sewn to the center flap inside the top. Wrap the strap around the horizontal tube of the sport bar and pull it toward the front of the vehicle. Thread it through the footman loop located above the windshield. Pull the end of the strap back and thread it through the buckle on the strap. Do not pull the strap tight at this time.

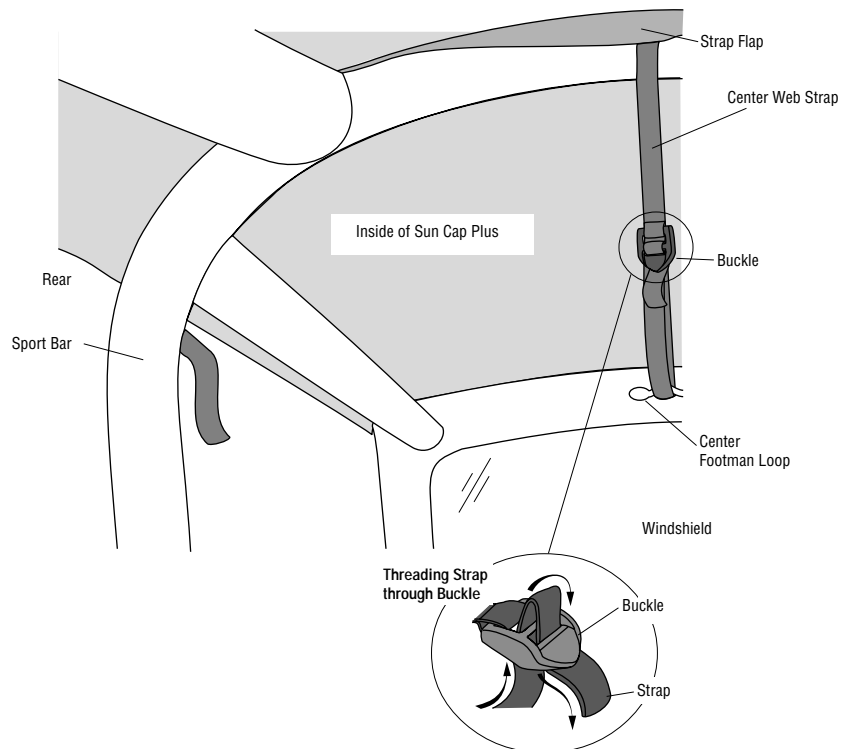

Step Three

Locate the straps sewn to the rear corners of the Sun Cap Plus. Pull the straps toward the rear and wrap them under the seat belt assembly mounts and around the rear sport bar. Pull them tight up towards buckle and thread the ends of the straps through the buckles. Pull the straps tight.

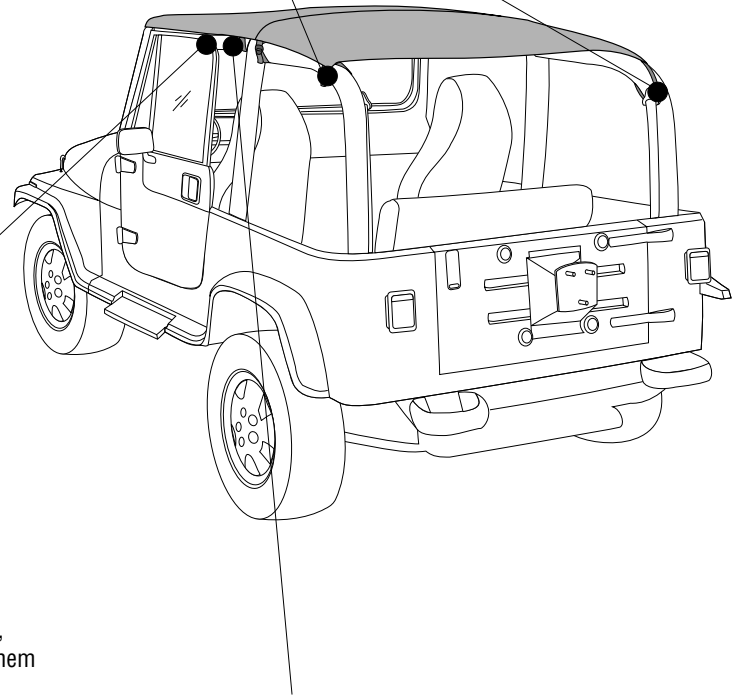
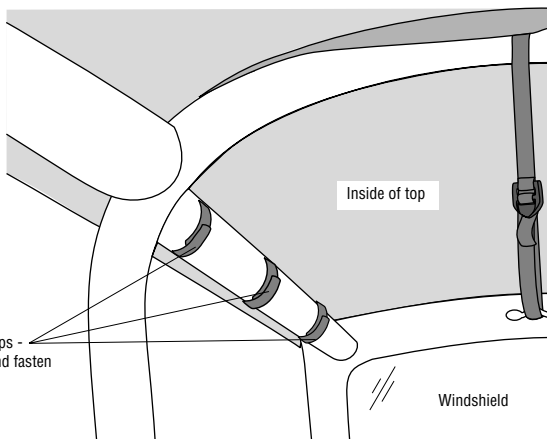
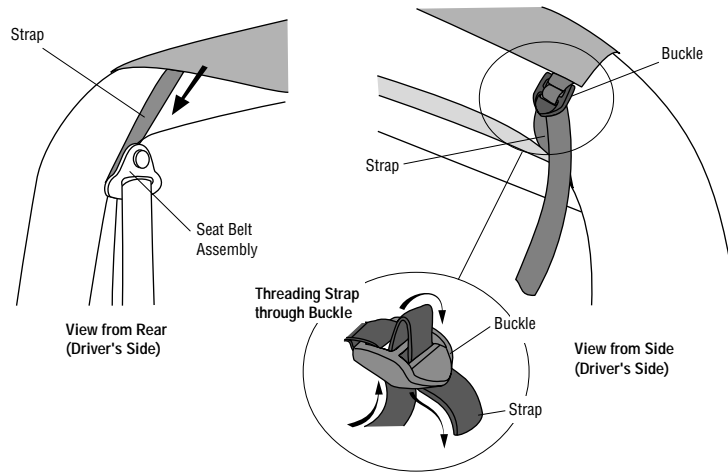

Step Four

Locate the three pairs of hook and loop strips sewn to each side of the top, above the door opening. Wrap the strips around the sport bar and fasten them to each other. Make sure that all the hook and loop is as tight as possible.

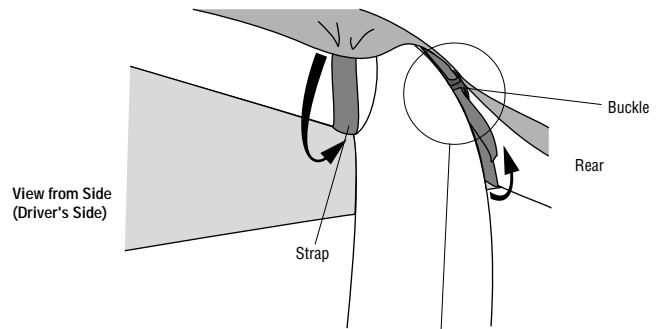

Step Five

Locate the web straps sewn to the top at the rear of the door opening (near the center seam of the top). Wrap the strap around the Horizontal Bar and under the Vertical Sports Bar at the rear of the door and thread it through the buckle. Pull the strap tight.

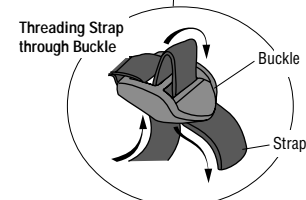

Make sure that all the straps are as tight as possible.

LIMITED WARRANTY

We warrant our product to be free from defects in material and workmanship, for the terms specified below, provided there has been normal use and proper maintenance. This warranty applies to the original purchaser only. All remedies under this warranty are limited to the repair or replacement of any item or items found by the factory to be defective within the time period specified.

If you have a warranty claim, first you must call our factory at the number below for instructions. You must retain proof of purchase and submit a copy with any items returned for warranty work. Upon completion of warranty work, if any, we will return the repaired or replaced item or items to you freight prepaid. Damage to our products caused by accidents, fire, vandalism, negligence, misinstallation, misuse, Acts of God, or by defective parts not manufactured by us, is not covered under this warranty.

THE WARRANTY TIME PERIOD IS AS FOLLOWS: ALL "SOFT GOODS" MANUFACTURED BY OUR COMPANY (USING PRIMARILY VINYL, PLASTICS, AND/OR FOAM): ONE YEAR FROM DATE OF PURCHASE.

ANY IMPLIED WARRANTIES OF MERCHANTABILITY AND/OR FITNESS FOR A PARTICULAR PURPOSE CREATED HEREBY ARE LIMITED IN DURATION TO THE SAME DURATION AND SCOPE AS THE EXPRESS WRITTEN WARRANTY. OUR COMPANY SHALL NOT BE LIABLE FOR ANY INCIDENTAL OR CONSEQUENTIAL DAMAGE.

Some states do not allow limitations on how long an implied warranty lasts, or the exclusion or limitation of incidental or consequential damages, so the above limitations or exclusions may not apply to you.

This warranty gives you specific legal rights, and you may also have other rights which vary from state to state.

For further information or request for warranty work, please contact: Customer Service
877-638-9509

*All or a portion of this product may be made in China.