

# POWER TAILGATE LOCK

# Instructions Model PL8160

## Parts Included

Power Lock  
Short Wiring Harness  
Wiring Harness  
Relay Wiring Cable  
Blue Connector Taps  
Cable Ties

## Tools Required

Philips Screwdriver  
10 MM socket  
Ratchet  
Ratchet Extension  
Pliers  
Side cutters  
Wire strippers

## CHEVY COLORADO / GMC CANYON

2005 & Up

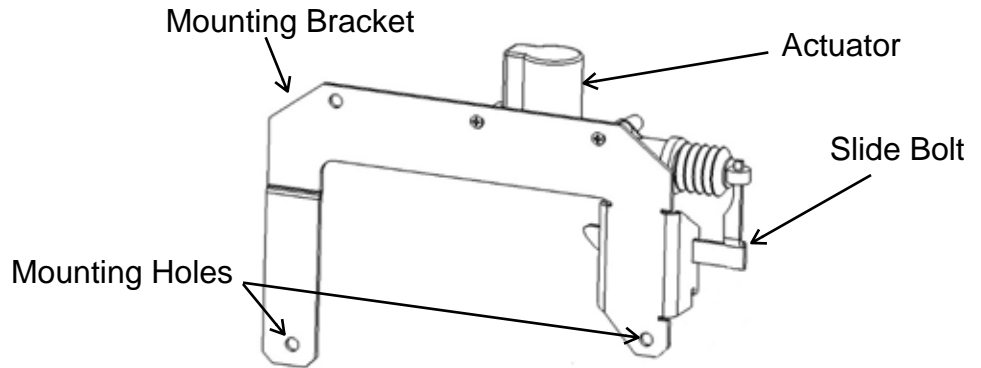

## Power Lock Installation

1. Open the tailgate and if applicable, remove the tailgate bed-liner.
2. Using a philips screwdriver, remove the 4 screws holding the access panel.
3. Remove the access panel and set aside.
4. Detach the two latch rods from the plastic retainers.
5. Remove the two 10 mm bolts from inside the tailgate to free the handle assembly.
6. Lift the tailgate in the up position, but do not fully engage in the latches.
7. While supporting the tailgate with one hand, pull the bottom of the handle out first (a), then carefully pull out the handle assembly from the top (b).
8. While the tailgate is in the open position, insert the POWER LOCK through the access panel opening and then towards the inside (top of tailgate), leaving it resting inside to allow room for re-installing the factory handle.
9. Re-install the factory handle by following step 6 and 7 in reverse order. Please be very careful in this step to not damage the tailgate paint.
10. Make sure that the POWER LOCK is in the unlocked position, with the Slide Bolt fully extended.

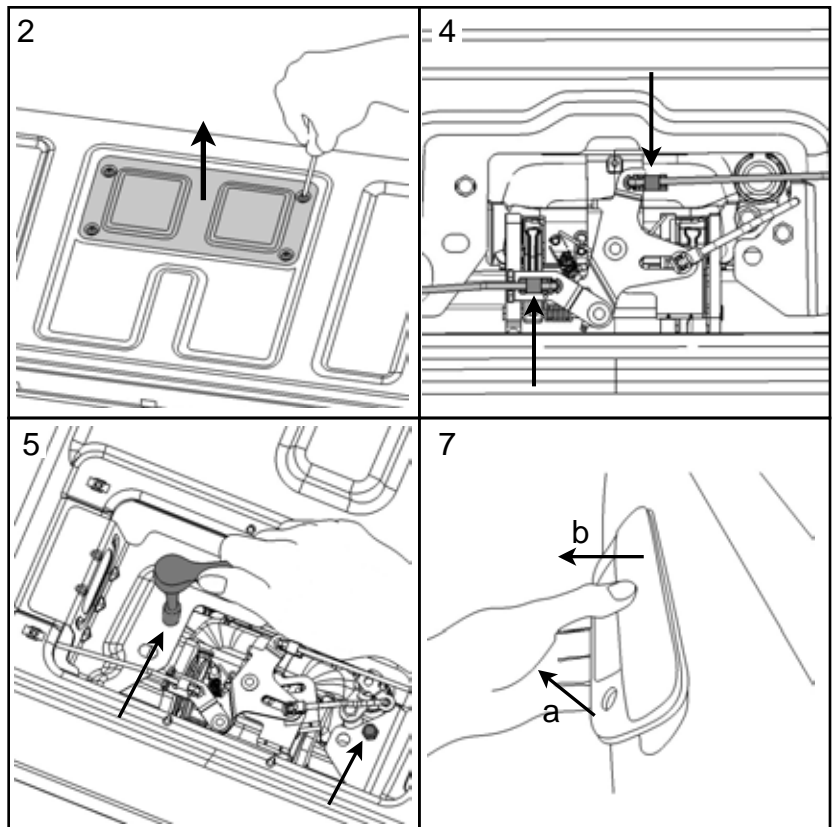

**POP & LOCK®**

11. While the tailgate is in the open position, support the factory handle with one hand while positioning the mounting holes of the POWER LOCK over the existing factory holes.
12. Thread by hand the two factory bolts back into the handle assembly and Power Lock. Tighten with ratchet and socket.
13. Re-attach the two latch rods to the plastic retainers of the factory handle assembly. Make sure that the plastic retainers snap properly in the closed position.
14. Tape the connector end of the short wiring harness to a coat hanger or electrical fish tape. Slip it down from inside the access panel area to the bottom of the tailgate and through one of the drain holes on passenger side.
15. Connect the short wiring harness to the POWER LOCK. Fasten the cable to the internal brace of the tailgate or wherever possible using cable ties but not to the latch rods.
16. Connect the other end of the short wiring harness to the Long wiring harness and fasten the connector in an area that it is accessible for tailgate removal. Make sure that the tailgate cannot pinch the harness when opened or closed.
17. Run the long wiring harness underneath the truck passenger's side, into the fender well and to the engine compartment. Make sure to use enough cable ties to prevent the wiring harness from moving. Also make sure to keep the cable away from the exhaust system or moving parts.
18. Mount the Relay kit on a suitable location near the battery.
19. Attach the long wiring harness to the relay harness by attaching the green to green and blue to brown wires.
20. Run the **purple** and **gray** wire bundle through the firewall of the truck. Please try to follow the OEM wiring routes if possible.
21. Locate the **Tan** and **Gray** wires behind the kick panel on the driver side of the vehicle.
22. Install a blue connector tap on each wire and slide the purple and the gray connectors over the blue connector taps.
23. Attach the relay harness to the battery by connecting the fused lead (red) to the positive terminal and the black lead to the negative terminal.
24. Test the POWER LOCK by locking and unlocking the power door locks. If the POWER LOCK is in reversed order to the vehicle power lock, then reverse the purple and gray wires behind the kick panel.
25. Re-install the access panel on the tailgate and the tailgate bed-liner if applicable.

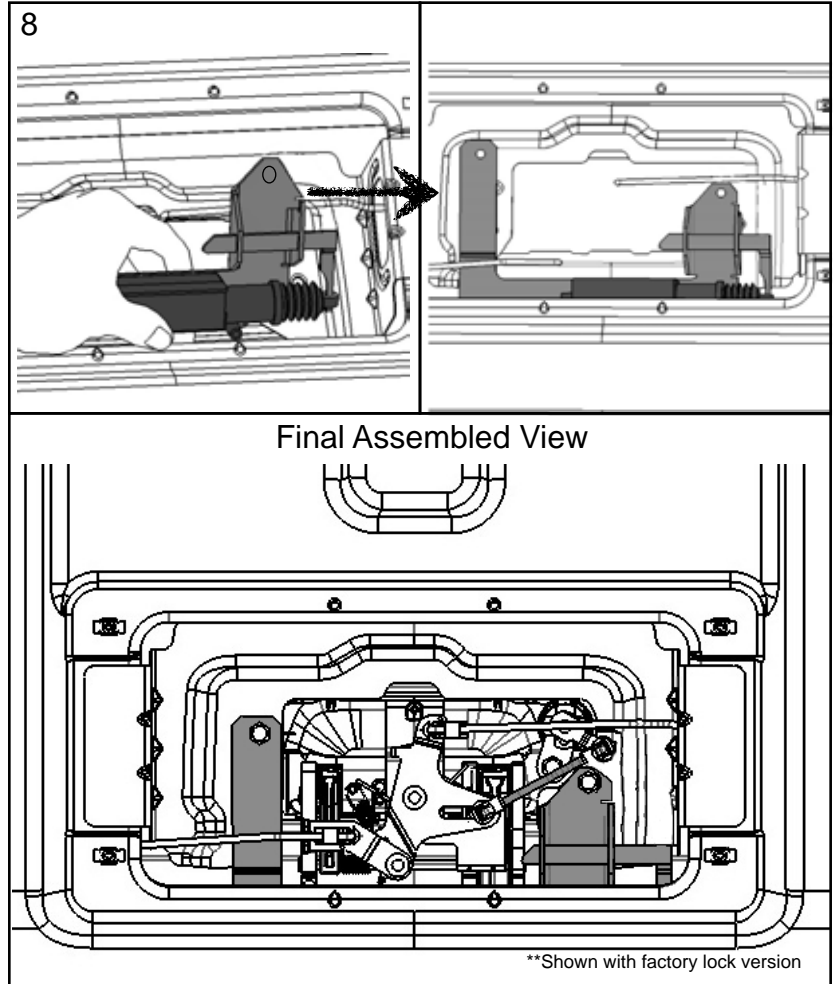

## LIMITED WARRANTY TERMS AND CONDITIONS

- (1) **Installation.** Pop & Lock™, LLC (and Pop & Lock™ Corporation) is not responsible for installing the Pop & Lock™ or for the harm suffered by any person as a result installing it.
- (2) **Warranties.**
- a. Customer acknowledges that it is unreasonable to believe that any device whatever will prevent a theft in the case of every attempt and that the most that can be expected from a so-called anti-theft or security device is that it will deter many thieves.
  - b. **POP & LOCK™ LLC. (and Pop & Lock™ Corporation) MAKES, AND CUSTOMER RECEIVES, NO WARRANTY, EXPRESSED OR IMPLIED, EXCEPT THE WARRANTIES OF TITLE TO THE POP & LOCK™ AND THEIR MERCHANTABILITY, PARTICULARLY NO WARRANTY OF FITNESS FOR A PARTICULAR USE OR PURPOSE OR AGAINST INFRINGEMENT.**
  - c. As Customer's only remedy, Pop & Lock™, LLC (and Pop & Lock™ Corporation) will repair or replace, at its option and without charge, any lock that is defective in material or workmanship when received by Customer and is returned to Pop & Lock™ LLC (and Pop & Lock™ Corporation), FOB Pop & Lock™ Corporation's offices, within one (1) year after it's receipt by the Customer. Pop & Lock LLC will ship all replacement, or repaired, Locks to Customer, FOB Pop & Lock™'s shipping point.
  - d. Factory support is only available for Pop & Lock™ products purchased as **new** through an Authorized Pop & Lock™ dealer.  
***Please Note: Pop & Lock™ Products purchased on auction sites such as Ebay, Amazon and Craigslist, to name a few, will not be covered under factory warranty under any circumstance. Pop & Lock™, LLC (and Pop & Lock™ Corporation) is unable to verify whether products sold through Auction Sites are new, used, or refurbished, and as such, Pop & Lock, LLC (and Pop & Lock™ Corporation) is unable to warranty such purchases. Pop & Lock, LLC advises using extreme caution when buying through auction sites as you'll be doing so at your own risk.***
- (3) **No Liability.** Pop & Lock™ Corporation is not liable for any loss or damage claimed by Customer or any third person to have been suffered or incurred as a result or, or related to, the Locks purchased under this Agreement, regardless of the circumstances or form of action, except any bodily injury or death for which Pop & Lock™ is liable under products-liability law. Without limiting the generality of the foregoing, in no event will Pop & Lock™ LLC be liable to Customer for any indirect, special, or consequential damages, regardless of the circumstances or the cause of action, particularly not for the value of a vehicle, or any other money damages in the event that a tailgate is stolen either notwithstanding the use of a Pop & Lock™ or when it has been returned for repair or replacement.

## END OF TERMS AND CONDITIONS

Please Mail Completed Warranty Form (below) In Self Addressed Envelope To:

**POP & LOCK LLC 1271 CONTRACT DRIVE GREEN BAY, WI USA 54304**

Additional Install Instructions and answers to technical questions can be found on our website at [www.popnlock.net](http://www.popnlock.net) or by calling

**Technical Support 1-800-342-5911**

**Monday – Friday 8am to 5pm CST**



## POP & LOCK™ LIMITED WARRANTY FORM

Please complete and mail this form to record your warranty with the manufacturer.

NAME \_\_\_\_\_

ADDRESS \_\_\_\_\_

CITY \_\_\_\_\_

STATE \_\_\_\_\_ ZIP \_\_\_\_\_

TELEPHONE # \_\_\_\_\_

EMAIL ADDRESS \_\_\_\_\_

POP & LOCK™ MODEL \_\_\_\_\_

VEHICLE YEAR \_\_\_\_\_

VEHICLE MAKE/MODEL \_\_\_\_\_

REASON FOR RETURN *(continue on other side)*: