

# INSTRUCTION SHEET

## Denso Starter Pinion PIN 604, 605, 610, 611, and 612

We want to help! If you have any comments or difficulty with this product, please contact technical support at



1833 Downs Drive  
West Chicago, IL 60185  
(800) 862-7223

e-mail: tech@powermastermotorsports.com

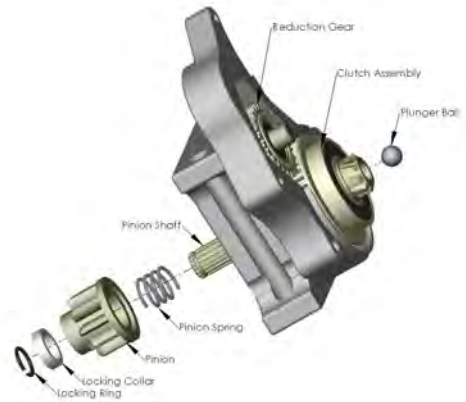

Figure 4

### Installation instructions for pinion P/N: 604, 605, 610, 611 & 612

Removal and installation steps:

1. Remove the four bolts holding the *drive end housing* to the starter body. Two bolts parallel the starter's motor and the other two are found in the *drive end housing* near the *pinion gear*. **NOTE: The plunger ball may roll out of the pinion shaft and may be lost if care is not taken (Figure 1). The reduction gear and its four roller bearings and holder should be temporarily removed from the drive end housing or secured in the housing with tape.**
2. Push the pinion shaft forward into the *clutch assembly* while simultaneously pushing the *locking collar* and *pinion* back (Figure 2).
3. This will expose the *locking ring* on the end of the *pinion shaft* (Figure 3). Use a

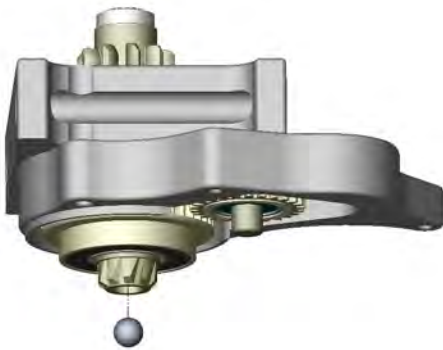

Figure 1

flat screwdriver to spread the *lock ring* and remove.

4. Remove the *locking collar*, *pinion*, and *pinion spring* (Figure 4).
5. Repeat step two and install the **new pinion spring, pinion, locking collar, and locking ring**. **NOTE: Be certain that the notch inside the locking collar is toward the locking ring when installed.** When the *locking ring* is in its groove on the *pinion shaft*, squeeze the *ring* together with pliers to assure a tight fit. Release the *shaft, pinion* and *collar*. If the *locking collar* does not completely cover the *locking ring*, lightly tap on the pinion end of the *shaft*. **NOTE: The pinion spring's tension holds the locking collar forward with its notch over the locking ring to prevent it from spreading during use.**

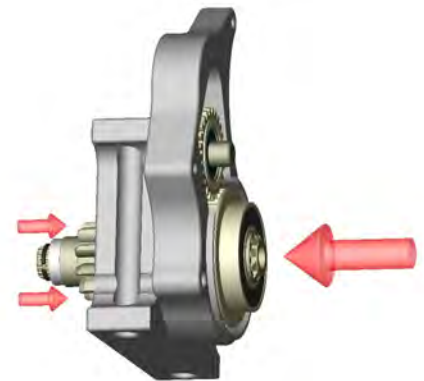

Figure 2

6. Reinstall the *reduction gear* (if removed) and reattach the *drive end housing* to the starter body. Tighten the four assembly bolts in an even fashion.

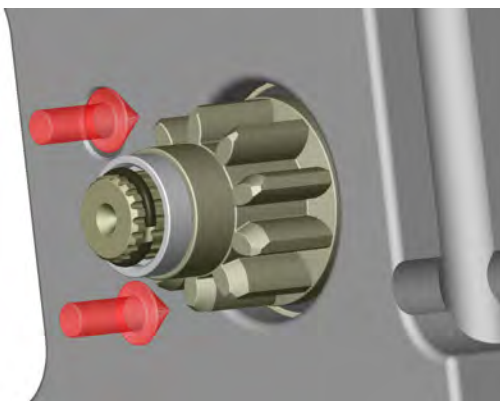

Figure 3

Part Description	P/N 604 Qty.	P/N 605 Qty.	P/N 610 Qty.	P/N 611 Qty.	P/N 612 Qty.
Locking ring	1	1	1	1	1
Locking collar	1	1	1	1	1
Pinion spring	1	1	1	1	1
Pinion (11 tooth)	1				
Pinion (9 tooth)		1			
Pinion (10 tooth for Mopar applications)			1		
Pinion (9 tooth for Bert/Brinn applications)				1	
Pinion (10 tooth for Flat Head Ford applications)					1