



OMIX-ADA, Inc.

460 HORIZON DR. SUITE 400 | SUWANEE, GA 30024 | PHONE: 770-614-6101 | FAX: 770-614-6069 | info@omix-ada.com

Part #11504.15

TJ Rock Slider Panels

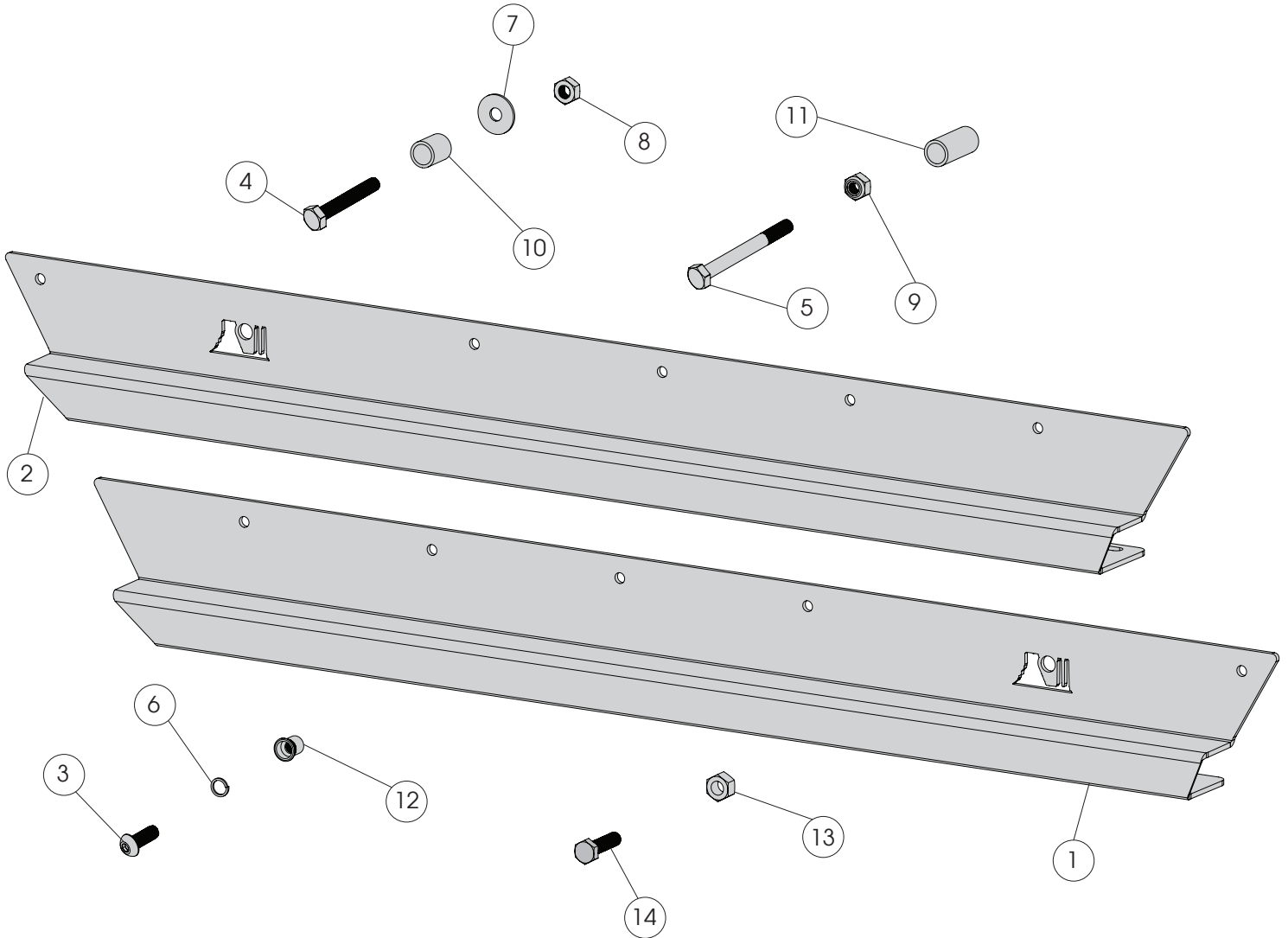

Components

- | | | | |
|--------------------------|------|---------------------|------|
| 1. Rock Slider Panel, LH | (1) | 8. M10 Nut | (10) |
| 2. Rock Slider Panel, RH | (1) | 9. M10 Lock Nut | (6) |
| 3. M10 Button Head Bolt | (10) | 10. 25mm Spacer | (4) |
| 4. M10 Short Hex Bolt | (4) | 11. 45mm Spacer | (2) |
| 5. M10 Long Hex Bolt | (2) | 12. M10 Rivet Nut | (2) |
| 6. M10 Lock Washer | (10) | 13. Hex Spacer Tool | (1) |
| 7. M10 Flat Washer | (40) | 14. Hex Bolt Tool | (1) |

OMIX-ADA® TECHNICAL SUPPORT

PHONE: M-F 8am - 5pm EST 1-800-449-6649 | EMAIL: techsupport@omix-ada.com

FOR WARRANTY INFORMATION VISIT: www.Omix-Ada.com



OMIX-ADA, Inc.

460 HORIZON DR. SUITE 400 | SUWANEE, GA 30024 | PHONE: 770-614-6101 | FAX: 770-614-6069 | info@omix-ada.com

TJ Rock Slider Panels

1. Remove any side steps or other panels before beginning.
2. Ensure all vehicle surfaces that are covered by Rock Slider Panels are clean before beginning.
3. Carefully position Rock Slider Panels between flares so the fit is snug.

NOTICE Flares may need to be loosened to allow proper fitment of Rock Sliders.

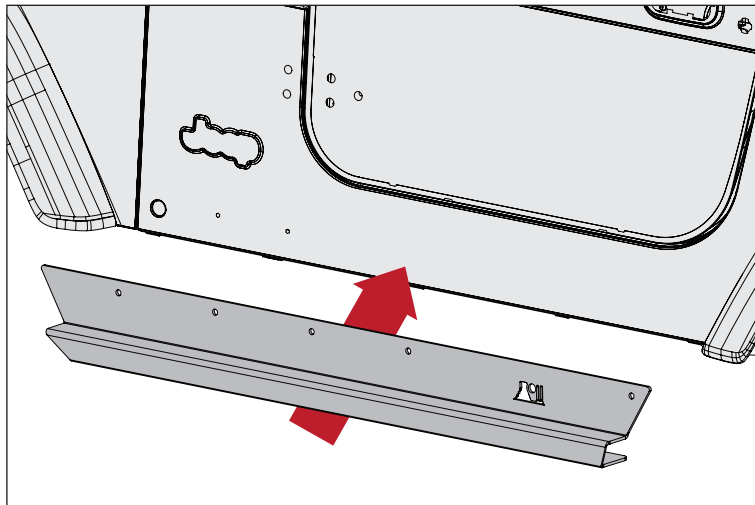

4. Once positioned, mark and center punch 5 side holes for drilling.

NOTICE Before drilling, ensure all wires on inside of vehicle are out of the way.

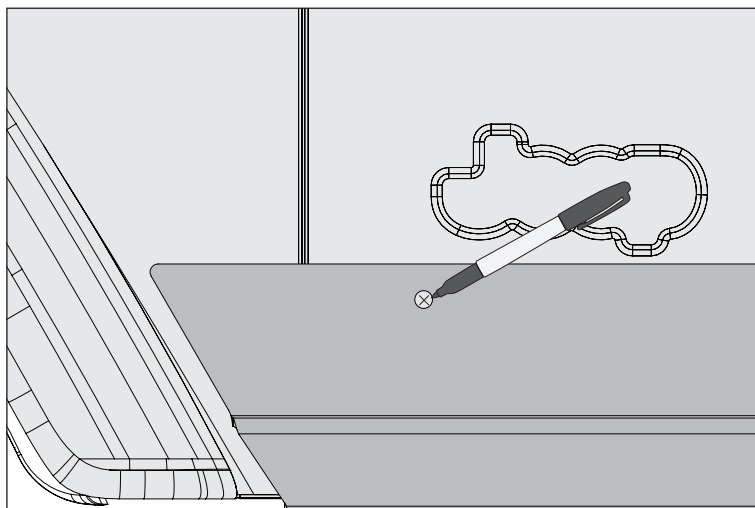

5. Beginning with a 3/16" bit, drill 5 mounting holes into side body. Continue with 7/16" bit to finish full diameter of mounting points. Clean any metal chips and shavings from vehicle before continuing.

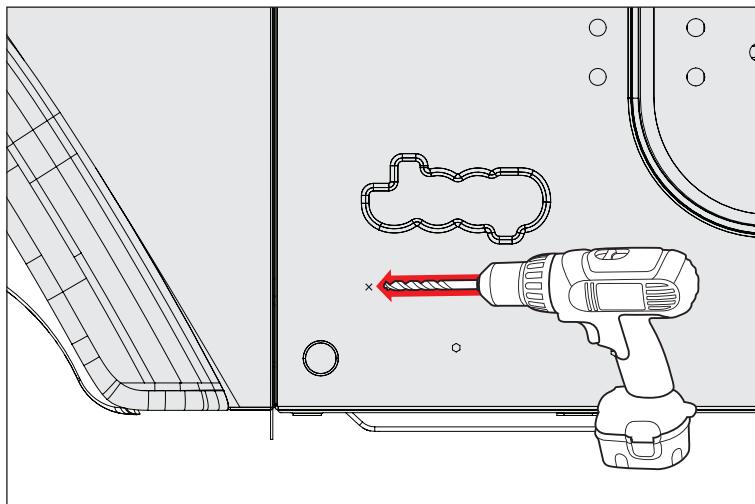



OMIX-ADA, Inc.



460 HORIZON DR. SUITE 400 | SUWANEE, GA 30024 | PHONE: 770-614-6101 | FAX: 770-614-6069 | info@omix-ada.com

TJ Rock Slider Panels

6. For TJ models 2003 and newer, the rear-most mounting point will require M10 Rivet Nuts. Insert Nut into rear-most hole and align with Clearance Nut Tool.

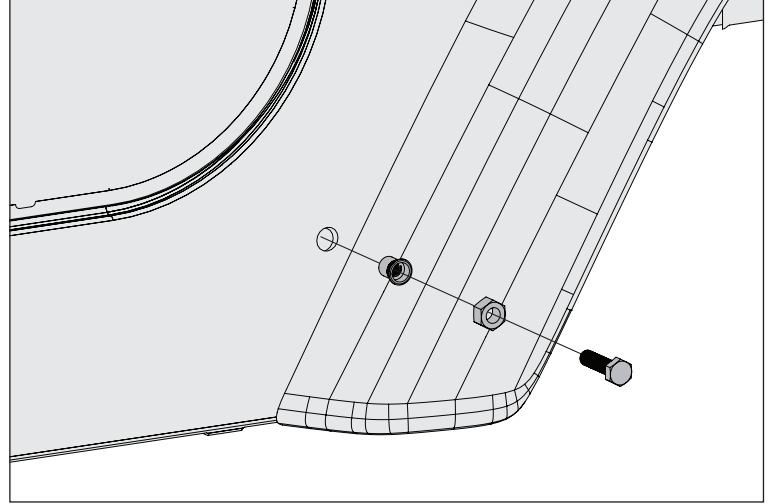

7. Insert Hex Bolt Tool into Hex Spacer Tool and thread into Rivet Nut.

8. Using two wrenches to keep Hex Spacer Tool from spinning, tighten Hex Bolt Tool until Rivet Nut is fully collapsed.

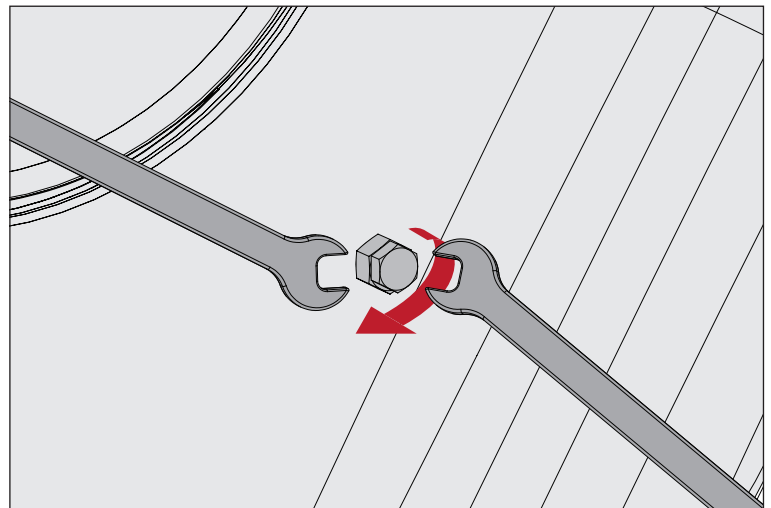

9. Remove Hex Spacer Tool and Hex Bolt Tool.

10. Install Rock Slider Panels to vehicle using M10 Button Head Bolts, M10 Flat Washers, and M10 Nuts.

11. Evenly hand tighten bolts until Rock Slider Panels are in correct position.

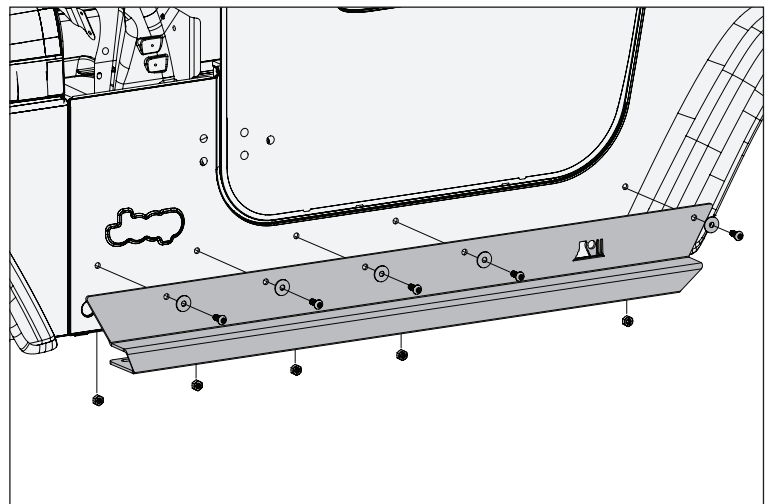



OMIX-ADA, Inc.

460 HORIZON DR. SUITE 400 | SUWANEE, GA 30024 | PHONE: 770-614-6101 | FAX: 770-614-6069 | info@omix-ada.com

TJ Rock Slider Panels

12. Mark and center punch three bottom holes, using holes in Rock Slider Panel as a guide.

13. Remove Rock Slider Panels.

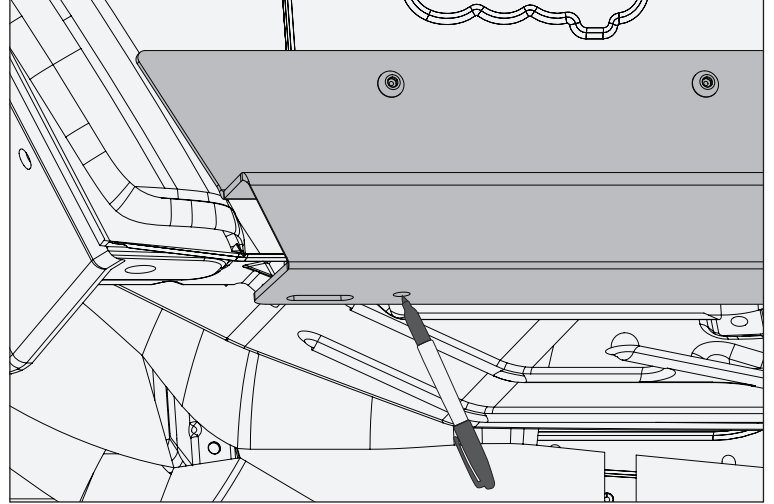

NOTICE Before drilling, pull away carpeting and anything that may be in way of drill.

14. Begin drilling with 3/16" bit, then 7/16" for correct diameter.

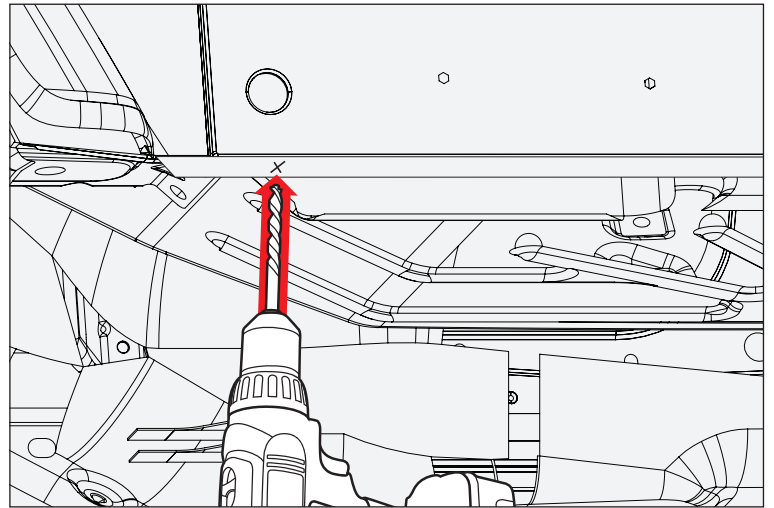

15. Attach side mounting holes in Rock Slider Panels using M10 Button Head Bolts, Flat Washers, Lock Washers, and M10 Nuts.

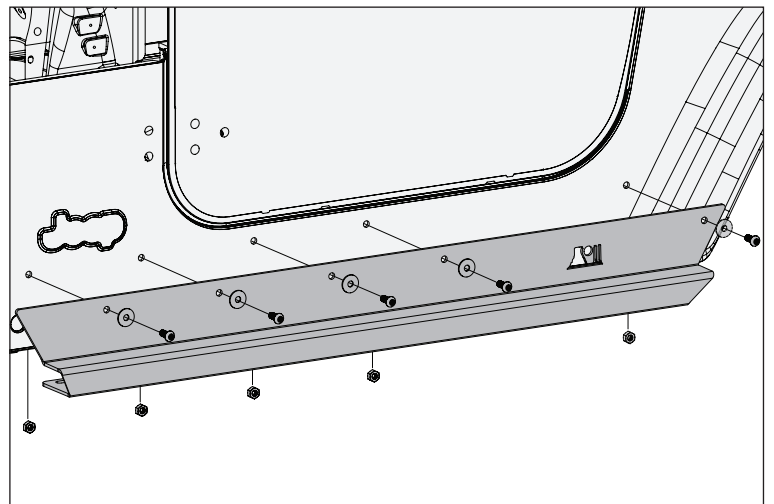



OMIX-ADA, Inc.

460 HORIZON DR. SUITE 400 | SUWANEE, GA 30024 | PHONE: 770-614-6101 | FAX: 770-614-6069 | info@omix-ada.com

TJ Rock Slider Panels

16. Attach center bottom hole using M10 Long Hex Head Bolt, Flat Washer, 45mm Spacer, and Lock Nut.

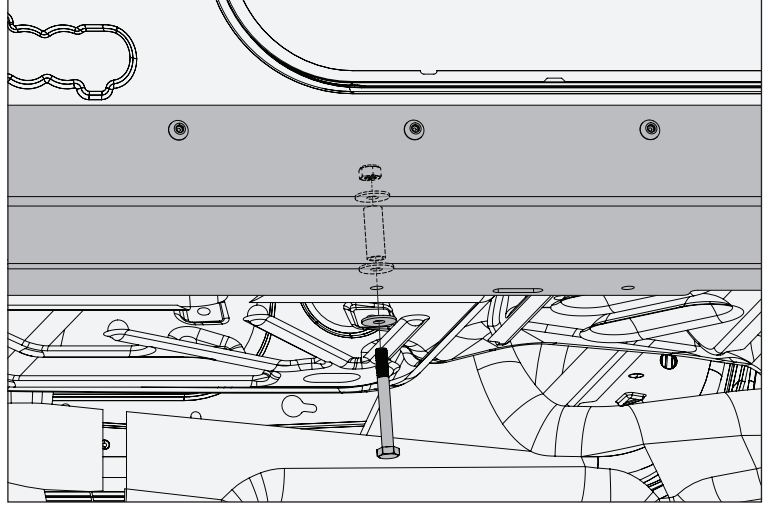

17. Attach outer bottom holes using M10 Short Hex Head Bolt, Flat Washer, 25mm Spacer, and Lock Nut.

18. Fully tighten all bolts.

