



R-SERIES 36®

INSTALLATION GUIDE



KIT INCLUDES

(1) R-Series 36 Light with Cover

(2) Electrical Terminal Hardware Kit

IMPORTANT

It is strongly recommended that this product be installed by a professional.

Operating Limitations: Input Voltage 10-36V DC improper voltage will result in damage to light.

Always disconnect battery before servicing any fuses or electrical system.

INSTALLATION INSTRUCTIONS

General Specs

R-Series 36 LED lights are not polarity sensitive. Either positive or negative wires can be applied to either screw terminal.

1. Remove existing light and any associated wiring from cavity.
2. Install positive and negative battery leads to the back of R-Series 36 LED light using supplied #8-32 screw and washer.
3. Install R-Series 36 LED light into cavity. When routing wires, take care to avoid any heat sources and sharp or abrasive surfaces.

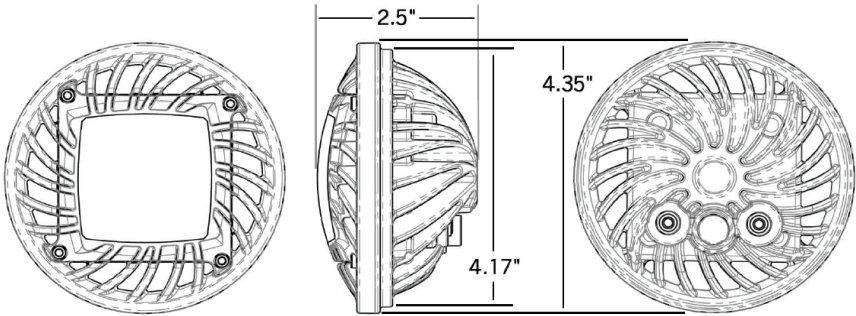

WARRANTY INFORMATION

For warranty information visit www.rigidindustries.com/about/warranty

FOLLOW US ON FACEBOOK AT
facebook.com/RigidIndustries

779 N Colorado St, Gilbert, AZ 85233 • 855.760.5337 • www.RigidIndustries.com

Rigid Industries, R-Series 36, and R-Series are registered and/or common law marks owned by JST Performance, LLC, a Delaware limited liability company d/b/a Rigid Industries

PKG-IS-R-SERIES-B